



POLARIS®

RANGER®



2018
OWNER'S MANUAL

RANGER® EV

⚠ WARNING

Read, understand, and follow all of the instructions and safety precautions in this manual and on all product labels.

Failure to follow the safety precautions could result in serious injury or death.

⚠ WARNING

The engine exhaust from this product contains chemicals known to the State of California to cause cancer, birth defects or other reproductive harm.



For videos and more information about a safe riding experience with your Polaris vehicle, scan this QR code with your smartphone.



2018 Owner's Manual

RANGER® EV

POLARIS® and RANGER® are trademarks of POLARIS Industries Inc.

Copyright 2017 Polaris Industries Inc. All information contained within this publication is based on the latest product information at the time of publication. Due to constant improvements in the design and quality of production components, some minor discrepancies may result between the actual vehicle and the information presented in this publication. Depictions and/or procedures in this publication are intended for reference use only. No liability can be accepted for omissions or inaccuracies. Any reprinting or reuse of the depictions and/or procedures contained within, whether whole or in part, is expressly prohibited.

The original instructions for this vehicle are in English. Other languages are provided as translations of the original instructions.

Printed in U.S.A.

2018 *RANGER*® Owner's Manual
9928293

Thank you for purchasing a POLARIS vehicle, and welcome to our world-wide family of POLARIS enthusiasts. Be sure to visit us online at www.polaris.com for the latest news, new product introductions, upcoming events, career opportunities and more.

Here at POLARIS we proudly produce an exciting line of utility and recreational products.

- Snowmobiles
- All-terrain vehicles (ATVs)
- Low emission vehicles (LEVs)
- *RANGER*® utility vehicles
- BRUTUS® work vehicles
- SLINGSHOT® three wheel motorcycles
- RZR® sport vehicles
- GEM® vehicles
- INDIAN® motorcycles
- POLARIS POWER® generators
- POLARIS DEFENSE® combat vehicles
- Timbersled® Snow Bikes

We believe POLARIS sets a standard of excellence for all utility and recreational vehicles manufactured in the world today. Many years of experience have gone into the engineering, design, and development of your POLARIS vehicle, making it the finest machine we've ever produced.

For safe and enjoyable operation of your vehicle, be sure to follow the instructions and recommendations in this owner's manual. Review the safety DVD that came with your vehicle. POLARIS also recommends that all drivers take the ROHVA safety e-course and a ROHVA hands-on safety training course. Visit www.rohva.org or call 866-267-2751.

Your manual contains instructions for minor maintenance, but information about major repairs is outlined in the POLARIS Service Manual and can be performed by a factory certified Master Service Dealer® (MSD) Technician.

Your POLARIS dealer knows your vehicle best and is interested in your total satisfaction. Your POLARIS dealership can perform all of your service needs during, and after, the warranty period.

WELCOME

Introduction	7
Safety	11
Features and Controls	29
Operation	47
Winch Guide.	63
Maintenance	75
Specifications	97
POLARIS Products	101
Troubleshooting	103
Warranty	105
Maintenance Log	113

INTRODUCTION

This POLARIS vehicle is an off-road vehicle. Familiarize yourself with all laws and regulations concerning the operation of this vehicle in your area.

The following signal words and symbols appear throughout this manual and on your vehicle. Your safety is involved when these words and symbols are used. Become familiar with their meanings before reading the manual.

WARNING

WARNING indicates a hazardous situation that, if not avoided, may result in death to the operator, bystanders or person(s) inspecting or servicing the vehicle.

CAUTION

CAUTION indicates special precautions that must be taken to avoid vehicle damage or property damage.

CAUTION

SAFETY ALERT CAUTION indicates a potential hazard that may result in minor personal injury or damage to the vehicle.

IMPORTANT

IMPORTANT provides key reminders during disassembly, assembly, and inspection of components.

NOTICE

NOTICE provides key information by clarifying instructions.



The Prohibition Safety Sign indicates an action **NOT** to take in order to avoid a hazard.



The Mandatory Action Sign indicates an action that **NEEDS** to be taken to avoid a hazard.

WARNING

Failure to heed the warnings and safety precautions contained in this manual can result in severe injury or death. Your POLARIS vehicle is not a toy and can be hazardous to operate. This vehicle handles differently than cars, trucks or other off-road vehicles. A collision or rollover can occur quickly, even during routine maneuvers like turning, or driving on hills or over obstacles, if you fail to take proper precautions.

- Read this owner's manual and review the safety DVD that came with your vehicle. A free extra copy of the DVD can be obtained by contacting your local POLARIS dealer. Understand all safety warnings, precautions and operating procedures before operating the vehicle. Keep this manual with the vehicle.
- Never operate this vehicle without proper instruction. Take an authorized training course. Visit www.rohva.org or call 866-267-2751.
- This vehicle is an ADULT VEHICLE ONLY. You MUST be at least age 16 and have a valid driver's license to operate this vehicle.
- Always use the cab nets (or doors) while riding in this vehicle. Always keep hands, feet and all other body parts inside the vehicle at all times.
- Always wear a helmet, eye protection, gloves, long-sleeve shirt, long pants and over-the-ankle boots.
- Never use this vehicle with drugs or alcohol, as these conditions impair judgment and reduce operator reaction time.
- Complete the New Operator Driving Procedures outlined in this manual. Never allow a guest to operate this vehicle until the guest has completed the New Operator Driving Procedures.
- Never permit a guest to operate this vehicle unless the guest has reviewed the owner's manual and all safety labels and has completed a safety training

EUROPEAN VIBRATION AND NOISE

The driver-perceived noise and hand/arm and whole body vibration levels of this machinery is measured per EN 15997.

The operating conditions of the machinery during testing:

The vehicles were in like-new condition. The environment was controlled as indicated by the test procedure(s).

The uncertainty of vibration exposure measurement is dependent on many factors, including:

- Instrument and calibration uncertainty
- Variations in the machine such as wear of components
- Variation of machine operators such as experience or physique
- Ability of the worker to reproduce typical work during measurements
- Environmental factors such as ambient noise or temperature

VEHICLE IDENTIFICATION NUMBERS

Record your vehicle's identification numbers and key number in the spaces provided. Remove the spare key and store it in a safe place. An ignition key can be duplicated only by ordering a POLARIS key blank (using your key number) and mating it with one of your existing keys. The ignition switch must be replaced if all keys are lost.

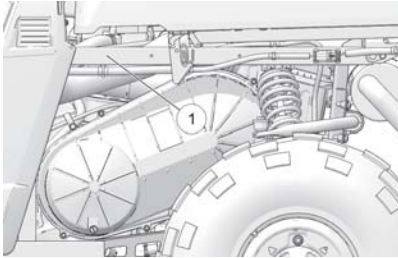

① Vehicle Identification Number (VIN)

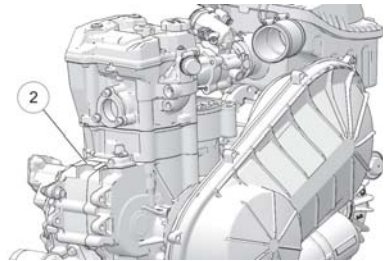

② Engine Serial Number

Vehicle Model Number:	
Vehicle Identification Number (VIN):	
Engine Serial Number:	
Key Number	

SAFETY

SAFETY TRAINING

Safety training is a top priority for POLARIS. POLARIS strongly encourages you and any family members who will be riding this vehicle to take a training course.

ROHVA (Recreational Off-Highway Vehicle Association) provides both an online safety e-course and a hands-on safety course. Visit www.rohva.org or call 866-267-2751.

Your POLARIS vehicle is considered an off-road vehicle. Familiarize yourself with all laws and regulations concerning the operation of this vehicle in your area.

We strongly advise you to strictly follow the recommended maintenance program outlined in your owner's manual. This preventive maintenance program is designed to ensure that all critical components on your vehicle are thoroughly inspected at specific intervals.

For more information about recreational off-road vehicle safety in the United States, visit www.rohva.org, call 866-267-2751 or call POLARIS at 800-342-3764.

SAFE RIDING GEAR

Always wear helmet, eye protection, gloves, long-sleeve shirt, long pants, over-the-ankle boots and seat belt at all times. Protective gear reduces the chance of injury.

RIDER COMFORT

Under certain operating conditions, heat generated by the engine and exhaust system can elevate temperatures in the rider cab area. The condition occurs most frequently when a vehicle is being operated in high ambient temperatures at low speeds and/or high load conditions for an extended period of time. The use of certain windshield, roof and/or cab systems may contribute to this condition by restricting airflow. Any discomfort due to heat buildup in this area can be minimized by wearing proper riding apparel and by varying speeds to increase airflow.



① Helmet

② Eye Protection

③ Long Sleeves

④ Gloves

⑤ Long Pants

⑥ Over-the-Ankle Boots

HELMET

Wearing a helmet can prevent a severe head injury. Whenever riding this POLARIS vehicle, always wear a helmet that meets or exceeds established safety standards.

Approved helmets in the USA and Canada bear a U.S. Department of Transportation (DOT) label.

Approved helmets in Europe, Asia and Oceania bear the ECE 22.05 label. The ECE mark consists of a circle surrounding the letter E, followed by the distinguishing number of the country which has granted approval. The approval number and serial number will also be displayed on the label.

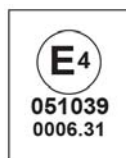

EYE PROTECTION

Do not depend on eyeglasses or sunglasses for eye protection. Whenever riding this POLARIS vehicle, always wear shatterproof goggles or use a shatterproof helmet face shield. POLARIS recommends wearing approved Personal Protective Equipment (PPE) bearing markings such as VESC 8, V-8, Z87.1, or CE. Make sure protective eye wear is kept clean.

GLOVES

Wear gloves for comfort and for protection from sun, cold weather and other elements.

BOOTS

Wear sturdy over-the-ankle boots for support and protection. Never ride a POLARIS vehicle with bare feet or sandals.

CLOTHING

Wear long sleeves and long pants to protect arms and legs.

SAFETY

SAFETY LABELS AND LOCATIONS

Warning labels have been placed on the vehicle for your protection. Read and follow the instructions of the labels on the vehicle carefully. If any of the labels depicted in this manual differ from the labels on your vehicle, always read and follow the instructions of the labels on the *vehicle*.

If an informational or graphic label becomes illegible or comes off, contact your POLARIS dealer to purchase a replacement. Replacement *safety* labels are provided by POLARIS at no charge. The part number is printed on the label.

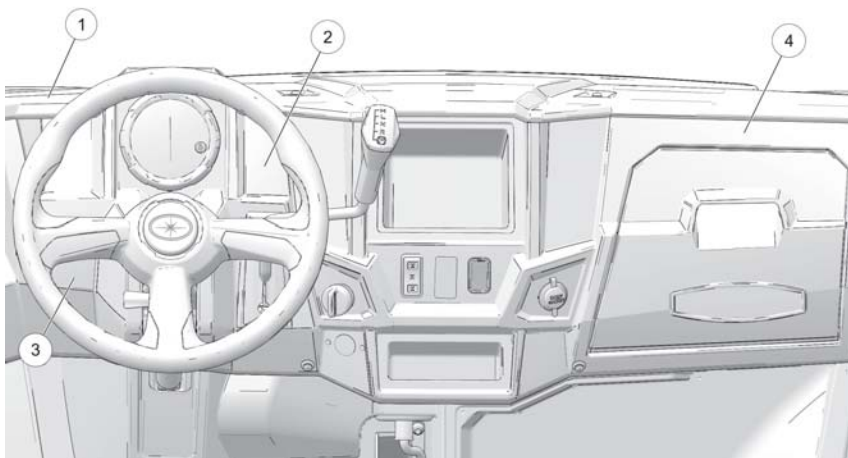

① Seat Belt / Driver Warning

② Shift Caution

③ Proper Use Warning

④ Max Payload Warning

SHIFT CAUTION CAUTION

To avoid transmission damage, shift only when vehicle is stationary and at idle. **APPLY BRAKE TO START.** When this vehicle is not in operation, or unattended, place shift in the park position.

PROPER USE WARNING

WARNING

Require Proper Use of Your Vehicle

Do your part to prevent injuries:

- Do not allow careless or reckless driving.
- Make sure operators are 16 or older with a valid driver's license.
- Do not let people drive after using alcohol or drugs.
- Do not allow operation on public roads (unless designated for off-highway vehicle access) - collisions with cars and trucks can occur.
- Do not exceed seating capacity: 2 occupants.

Driving on public roads may be hazardous and could be a violation of the law.

SEAT BELT / DRIVER WARNING

WARNING

Improper vehicle use can result in SEVERE INJURY or DEATH

Be Prepared

- Fasten seat belt.
- Wear an approved helmet and protective gear.
- ALWAYS use vehicle cab nets and/or doors.
- Driver must be able to sit with back against seat, feet flat on the floor, and hands on steering wheel. Stay completely inside the vehicle.

Drive Responsibly

Avoid loss of control and rollovers:

- Avoid abrupt maneuvers, sideways sliding, skidding or fishtailing, and never do donuts.
- Slow down before entering a turn.
- Avoid hard acceleration when turning, even from a stop.
- Plan for hills, rough terrain, ruts and other changes in traction and terrain.
- Avoid paved surfaces.
- Avoid sidehilling (riding across slopes).

Be Sure to Pay Attention and Plan Ahead

If you think or feel the vehicle may tip or roll, reduce your risk of injury:

- Keep a firm grip on the steering wheel and brace yourself.
- Do not put any part of your body outside of the vehicle for any reason.

SAFETY

PASSENGER/TIRE PRESSURE WARNING

- Passengers can be thrown off. This can cause serious injury or death.
- Never carry passengers in cargo box.

WARNING

IMPROPER TIRE PRESSURE OR OVERLOADING CAN CAUSE LOSS OF CONTROL RESULTING IN SERIOUS INJURY OR DEATH.

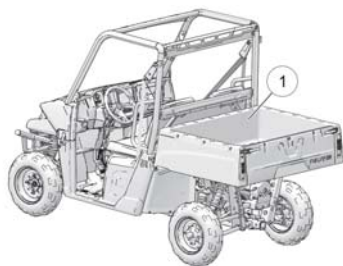

- Reduce speed and allow greater distance for braking when carrying cargo.
- Overloading or carrying tall, off-center, or unsecured loads will increase your risk of losing control. Loads should be centered and carried as low as possible in box.
- For stability on rough or hilly terrain, reduce speed and cargo.
- Be careful if load extends over the side of the box.

RANGER MID-SIZE	LSV-EV
MAXIMUM CARGO BOX LOAD	500 lbs. (226 kg)
TIRE PRESSURE IN PSI (KPa)	FRONT 20 (138) REAR 20 (138)
MAXIMUM WEIGHT CAPACITY INCLUDES WEIGHT OF OPERATOR, PASSENGER, CARGO AND ACCESSORIES	1000 lbs. (454 kg)
Read Operation & Maintenance Manual for more detailed loading information.	

FUEL TRANSPORT WARNING

The Fuel Transport Warning ① is located in the cargo box.

WARNING

NEVER carry fuel or other flammable liquids on this vehicle. Failure to follow this instruction could lead to serious burn injuries or death.

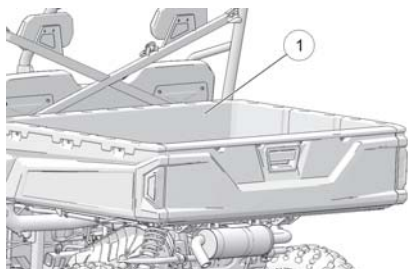

BATTERY COMPARTMENT WARNING

WARNING

- SULFURIC ACID in batteries will burn skin, eyes, and clothing. Do not tip batteries. Keep vent caps tight and level. In event of injury, flush with water and call physician immediately.
- HIGH VOLTAGE CABLES and terminals are contained within this compartment. Improper contact between battery terminals can result in electrical shorts. ELECTRICAL SHORTS can result in burns.
- Do not use high pressure water to wash the battery compartment. Damage to the vented batteries will result.
- Tampering with or unauthorized modification of this unit could result in serious personal injury, will void the warranty, and can result in permanent damage to the vehicle.
- Refer to your Owner's Manual or contact your local POLARIS dealer with any questions.

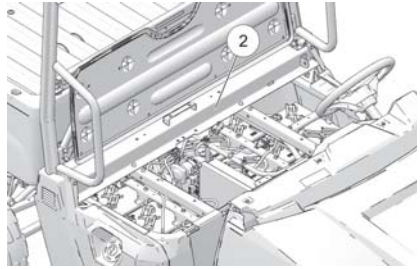

BATTERY CAUTION

The Battery Caution label located on the dashboard ①.

CAUTION

- Do not drive through water above the floor of the vehicle. Battery damage will occur.
- Batteries require regular maintenance.
- Failure to maintain batteries in accordance with the owners manual can result in battery damage, vehicle malfunction, fire and/or severe injury or death.
- Max towing speed 10 MPH (16 km/h) - drivetrain damage will occur if towed faster than 10 MPH (16 km/h).
- Set parking brake before leaving vehicle.
- Turn Power On key to "Off" position and remove when not in use.
- When towing vehicle, turn Power On key to "Off" position.

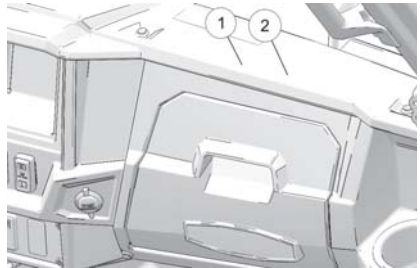

SAFETY

OPERATOR SAFETY

WARNING

Serious injury or death can result if you do not follow these instructions and procedures, which are outlined in further detail within your owner's manual.

- Read this entire manual and all labels carefully. Follow the operating procedures described.
- Never allow anyone under the age of 16 to operate this vehicle and never allow anyone without a valid driver's license to operate this vehicle.
- Do not carry a passenger until you have at least two hours of driving experience with this vehicle.
- All riders must be able to sit with backs against the seat, both feet flat on the floor and both hands on the steering wheel (if driving) or on a passenger hand hold.
- The driver and all passengers must wear helmet, eye protection, gloves, long-sleeve shirt, long pants, over-the-ankle boots and seat belt at all times.
- Always use the cab nets (or doors) while riding in this vehicle.
- Always keep hands and feet inside the vehicle at all times.
- Always keep both hands on the steering wheel and both feet on the floorboards of the vehicle during operation.
- Never permit a guest to operate this vehicle unless the guest has read this manual and all product labels.
- To reduce rollover risk, be especially careful when encountering obstacles and slopes and when braking on hills or during turns.
- This vehicle is for off road use only. Never operate on public roads (unless marked for off-road use). Always avoid paved surfaces.
- Never consume alcohol or drugs before or while operating this vehicle.
- Never operate at excessive speeds. Always travel at a speed proper for the terrain, visibility and operating conditions, and your experience.
- Never attempt jumps or other stunts.
- Always inspect the vehicle before each use to make sure it's in safe operating condition.
- Always follow the inspection procedures described in this manual.
- Always travel slowly and use extra caution when operating on unfamiliar terrain. Be alert to changing terrain.
- Never operate on excessively rough, slippery or loose terrain.
- Always follow proper procedures for turning. Practice turning at slow speeds before attempting to turn at faster speeds. Never turn at excessive speeds.
- Always have this vehicle checked by an authorized POLARIS dealer if it has been involved in an accident.
- Never operate this vehicle on hills too steep for the vehicle or for your abilities. Practice on smaller hills before attempting larger hills.
- Always follow proper procedures for climbing hills as described in this manual. Check the terrain carefully before attempting to climb a hill. Never climb hills with excessively slippery or loose surfaces. Never apply throttle suddenly. Never make sudden gear changes. Never go over the top of a hill at high speed.

- Always follow the proper procedures outlined in this manual for traveling downhill and for braking on hills. Check the terrain carefully before descending a hill. Never travel downhill at high speed. Avoid going downhill at an angle, which would cause the vehicle to lean sharply to one side. Travel straight down the hill where possible.
- Always check for obstacles before operating in a new area. Never attempt to operate over large obstacles such as large rocks or fallen trees. Always follow the proper procedures outlined in this manual when operating over obstacles.
- Always be careful of skidding or sliding. On slippery surfaces such as ice, travel slowly and exercise caution to reduce the chance of skidding or sliding out of control.
- Never operate your vehicle in fast-flowing water or in water deeper than that specified in this manual. Wet brakes may have reduced stopping ability. Test your brakes after leaving water. If necessary, apply them lightly several times to let friction dry out the pads.
- Always be sure there are no obstacles or people behind your vehicle when operating in reverse. When it's safe to proceed in reverse, move slowly. Avoid turning at sharp angles in reverse.
- Always use the proper size and type of tires specified in this manual. Always maintain proper tire pressure as specified on safety labels. Failure to adhere to either may impact vehicle stability, driveline durability, or general vehicle handling.
- Never modify this vehicle through improper installation or use of non-POLARIS approved accessories.
- Never exceed the stated load capacity for this vehicle. Cargo should be properly distributed and securely attached. Reduce speed and follow the instructions in this manual for hauling cargo or pulling a trailer. Allow a greater distance for braking.
- Always place the transmission in PARK before getting out of the vehicle. • Always engage the park brake (if equipped) when leaving the vehicle unattended.
- Always stop the engine before refueling. Remove flammable material containers from the box before filling them with fuel. Make sure the refueling area is well ventilated and free of any source of flame or sparks. Gasoline is extremely flammable.
- Always remove the ignition key when the vehicle is not in use to prevent unauthorized use by someone under the age of 16 or without a driver's license and proper training, or accidental starting.

SAFETY WARNINGS

WARNING

Failure to operate this vehicle properly can result in a collision, loss of control, accident or rollover, which may result in serious injury or death. Heed all safety warnings outlined in this section of the owner's manual and in the safety DVD provided with your vehicle. See the OPERATION section of the owner's manual for proper operating procedures.

OPERATING WITHOUT INSTRUCTION

Operating this vehicle without proper instruction increases the risk of an accident. The operator must understand how to operate the vehicle properly in different situations and on different types of terrain. Review the Operator Driving Procedures outlined in the manual.

All operators must read and understand the owner's manual and all warning and instruction labels before operating the vehicle. Never allow a guest to operate this vehicle until the guest has reviewed the New Operator Driving Procedures outlined in this manual.



AGE RESTRICTIONS

This vehicle is an **ADULT VEHICLE ONLY**.

Operation is prohibited for anyone under 16 years of age or anyone without a valid driver's license.

The operator must be tall enough to sit with back against the seat, both feet flat on the floor and both hands on the steering wheel.



USING ALCOHOL OR DRUGS

Operating this vehicle after consuming alcohol or drugs could adversely affect operator judgment, reaction time, balance and perception.

Never consume alcohol or drugs before or while operating this vehicle.



FAILURE TO INSPECT BEFORE OPERATING

Failure to inspect and verify that the vehicle is in safe operating condition before operating increases the risk of an accident. Always perform the pre-ride inspection before each use of your vehicle to make sure it's in safe operating condition. Always follow the inspection and maintenance procedures and schedules described in this owner's manual.

PROTECTIVE APPAREL

Riding in this vehicle without wearing an approved helmet and protective eyewear increases the risk of a serious injuries in the event of an accident.

Always wear a helmet, eye protection, gloves, long-sleeve shirt, long pants and over-the-ankle boots.

SEAT BELTS

Riding in this vehicle without wearing the seat belt increases the risk of serious injury in the event of rollover, loss of control, other accident or sudden stop. Seat belts may reduce the severity of injury in these circumstances.

The operator **MUST** wear the seat belt at all times.

SAFETY

CAB DOORS

Riding in this vehicle without closed and latched cab doors increases the risk of serious injury or death in the event of an accident or rollover. Always make sure all cab doors are closed and latched while riding in this vehicle. Cab doors are NOT intended to be used as arm rests. Always keep hands and feet inside the vehicle at all times.

CARRYING A PASSENGER

This POLARIS vehicle is a single-rider vehicle. Carrying a passenger greatly reduces the operator's ability to control the vehicle, which may result in an accident or rollover. Carrying a passenger in the cargo box could result in a fall from the vehicle or contact with moving components. Never carry a passenger on this vehicle.

OPERATING WITH A LOAD ON THE VEHICLE

The weight of both cargo and operator impacts vehicle operation and stability. For your safety and the safety of others, carefully consider how your vehicle is loaded and how to safely operate the vehicle. Follow the instructions in this manual for loading, tire pressure, gear selection and speed.

- **Do not exceed vehicle weight capacities.** The vehicle's maximum weight capacity is listed in the specifications section of this manual and on a label on the vehicle. When determining the weight you are adding to the vehicle, include the weight of the operator, accessories, loads in the rack or box and the load on the trailer tongue. The combined weight of these items must not exceed the maximum weight capacity.
- The recommended tire pressures are listed in the specifications section of this manual and on a label on the vehicle.

Always follow these guidelines:

UNDER ANY OF THESE CONDITIONS:	DO ALL OF THESE STEPS:
Operator and/or cargo exceeds half the maximum weight capacity	1. Slow down. 2. Verify tire pressure. 3. Use extra caution when operating.
Operating in rough terrain	
Operating over obstacles	
Climbing an incline	
Towing	

IMPROPER TIRE MAINTENANCE

Operating this vehicle with improper tires or with improper or uneven tire pressure could cause loss of control or accident. Always use the size and type of tires specified for your vehicle. Always maintain proper tire pressure as described in the owner's manual and on safety labels.

OPERATING ON PAVEMENT

This vehicle's tires are designed for off-road use only, not for use on pavement. Operating this vehicle on paved surfaces (including sidewalks, paths, parking lots and driveways) may adversely affect the handling of the vehicle and may increase the risk of loss of control and accident or rollover. Avoid operating the vehicle on pavement. If it's unavoidable, travel slowly, travel short distances and avoid sudden turns or stops.

OPERATING ON PUBLIC ROADS

Operating this vehicle on public streets, roads or highways could result in a collision with another vehicle. Never operate this vehicle on any public street, road or highway, including dirt and gravel roads (unless designated for off-highway use).

OPERATING AT EXCESSIVE SPEEDS

Operating this vehicle at excessive speeds increases the operator's risk of losing control. Always operate at a speed that's appropriate for the terrain, the visibility and operating conditions and your skills and experience.

JUMPS AND STUNTS

Exhibition driving increases the risk of an accident or rollover. **DO NOT** do power slides, "donuts", jumps or other driving stunts. Avoid exhibition driving.

TURNING IMPROPERLY

Turning improperly could cause loss of traction, loss of control, accident or rollover. Always follow proper procedures for turning as described in this owner's manual.

Avoid sharp turns. Never turn while applying heavy throttle. Never make abrupt steering maneuvers. Practice turning at slow speeds before attempting to turn at faster speeds.

SAFETY

IMPROPER HILL CLIMBING

Improper hill climbing could cause loss of control or rollover. Use extreme caution when operating on hills. Always follow proper procedures for hill climbing as described in this owner's manual.

DESCENDING HILLS IMPROPERLY

Improperly descending a hill could cause loss of control or rollover. Always follow proper procedures for traveling down hills as described in this owner's manual.

CROSSING HILLSIDES

Driving on a sidehill is not recommended. Improper procedure could cause loss of control or rollover. Avoid crossing the side of any hill unless absolutely necessary. If crossing a hillside is unavoidable, always follow proper procedures as described in this owner's manual.

STALLING WHILE CLIMBING A HILL

Stalling or rolling backwards while climbing a hill could cause a rollover. Maintain a steady speed when climbing a hill.

If you lose all forward speed:

Apply the brakes gradually until the vehicle is fully stopped. Place the transmission in reverse and slowly allow the vehicle to roll straight downhill while applying light brake pressure to control speed.

If you begin rolling downhill:

Never apply engine power. Apply the brakes gradually until the vehicle is fully stopped. Place the transmission in reverse and slowly allow the vehicle to roll straight downhill while applying light brake pressure to control speed.

OPERATING IN UNFAMILIAR TERRAIN

Failure to use extra caution when operating on unfamiliar terrain could result in an accident or rollover.

Unfamiliar terrain may contain hidden rocks, bumps, or holes that could cause loss of control or rollover.

Travel slowly and use extra caution when operating on unfamiliar terrain. Always be alert to changing terrain conditions.

OPERATING IMPROPERLY IN REVERSE

Improperly operating in reverse could result in a collision with an obstacle or person. Always follow proper operating procedures as outlined in this manual.

Before shifting into reverse gear, always check for obstacles or people behind the vehicle. When it's safe to proceed, back slowly.

SKIDDING OR SLIDING

Failure to use extra caution when operating on excessively rough, slippery or loose terrain could cause loss of traction, loss of control, accident or rollover. Do not operate on excessively slippery surfaces. Always slow down and use additional caution when operating on slippery surfaces.

Skidding or sliding due to loss of traction can cause loss of control or rollover (if tires regain traction unexpectedly). Always follow proper procedures for operating on slippery surfaces as described in this owner's manual.

OPERATING OVER OBSTACLES

Improperly operating over obstacles could cause loss of control or rollover. Before operating in a new area, check for obstacles. Avoid operating over large obstacles such as large rocks and fallen trees. Always follow the proper procedures outlined in this manual when operating over obstacles.

OPERATING THROUGH WATER

Operating through deep or fast-flowing water can cause loss of traction, loss of control, rollover or accident. Never operate in fast-flowing water or in water that exceeds the floor level of the vehicle.

Always follow proper procedures for operating in water as described in this owner's manual.

Wet brakes may have reduced stopping ability. After leaving water, test the brakes. Apply them lightly several times while driving slowly. The friction will help dry out the pads.

OPERATING ON FROZEN BODIES OF WATER

Severe injury or death can result if the vehicle and/or the operator fall through the ice. Never operate the vehicle on a frozen body of water unless you have first verified that the ice is sufficiently thick to support the weight and moving force of the vehicle, you and your cargo, together with any other vehicles in your party.

Always check with local authorities and residents to confirm ice conditions and thickness over your entire route. Vehicle operators assume all risk associated with ice conditions on frozen bodies of water.

OPERATING A DAMAGED VEHICLE

Operating a damaged vehicle can result in an accident. After any rollover or other accident, have a qualified service dealer inspect the entire machine for possible damage, including (but not limited to) seat belts, rollover protection devices, brakes, throttle and steering systems.

IMPROPER CARGO LOADING

Overloading the vehicle or carrying/towing cargo improperly may cause changes in stability and handling, which could cause loss of control or an accident.

- Always follow the instructions in this owner's manual for carrying cargo. See page 58.
- Never exceed the stated load capacity for this vehicle.

SAFETY

- Cargo should be properly distributed and securely attached.
- Reduce speed when carrying cargo or pulling a trailer. Allow a greater distance for braking.

POOR VISIBILITY

Operating this vehicle in darkness or inclement weather could result in a collision or accident, especially if operating on a road or street. This vehicle is not equipped with highway-approved lights. Operate this vehicle off-road only. Use caution and drive at reduced speeds in conditions of reduced visibility such as fog, rain and darkness. Clean headlights frequently and replace burned out headlamps promptly.

UNAUTHORIZED USE OF THE VEHICLE

Leaving the keys in the ignition can lead to unauthorized use of the vehicle by someone under the age of 16, without a drivers license, or without proper training. This could result in an accident or rollover. Always remove the ignition key when the vehicle is not in use.

HOT DRIVE SYSTEMS

The motor and controller are very hot during and after use of the vehicle. Hot components can cause burns and fire. Do not touch hot drive system components. Always keep combustible materials away from the drive system. Use caution when traveling through tall grass, especially dry grass. Always inspect areas near the drive system after driving through tall grass, weeds, brush and other tall ground cover. Promptly remove any grass or debris clinging to the vehicle.

VENTILATION WHEN CHARGING BATTERIES

Failure to provide adequate ventilation while charging batteries can result in an explosion. Volatile hydrogen gas is emitted during charging and may accumulate in pockets at the ceiling.

- Always ensure a minimum of 5 air changes per hour in the charging area.
- Always remove any storage covers from the vehicle and open any cab doors (if equipped) before charging.

PRECAUTIONS DURING MAINTENANCE

WARNING

Do not work in or near the battery compartment or on any other electrical component of the vehicle while charging the batteries. Always disconnect the main power connector before servicing or unplugging any electrical components.

Always follow all safety instructions in the maintenance portion of this owner's manual, as well as the following:

- Make sure the vehicle is properly immobilized before beginning any maintenance.
- Always block the chassis securely before working under the vehicle.
- Turn the key off and remove it from the vehicle.
- Insulate any tools used within the battery area to prevent sparks or battery explosion caused by shorting the battery terminals or wiring. Remove the batteries, or cover the exposed terminals with an insulating material.

EQUIPMENT MODIFICATIONS

Your POLARIS vehicle is designed to provide safe operation when used as directed. Modifications to your vehicle may negatively impact vehicle stability. Failure of critical machine components may result from operation with any modifications, especially those that increase speed or power. This vehicle may become less stable at speeds higher than those for which it is designed. Loss of control may occur at higher speeds.

Do not install any non-POLARIS-approved accessory or modify the vehicle for the purpose of increasing speed or power. Any modifications or installation of non-POLARIS-approved accessories could create a substantial safety hazard and increase the risk of bodily injury.

The POLARIS limited warranty on your POLARIS vehicle will be terminated if any non-POLARIS approved equipment and/or modifications have been added to the vehicle that increase speed or power.

The addition of certain accessories, including (but not limited to) mowers, blades, tires, sprayers, or large racks, may change the handling characteristics of the vehicle. Use only POLARIS-approved accessories, and familiarize yourself with their function and effect on the vehicle.

**FOR MORE INFORMATION ABOUT SAFETY
call POLARIS at 1-800-342-3764.**

FEATURES AND CONTROLS

COMPONENT LOCATIONS

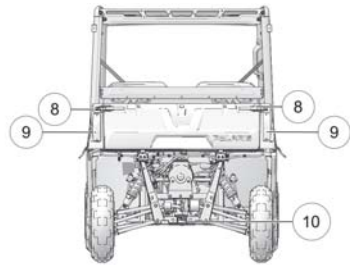
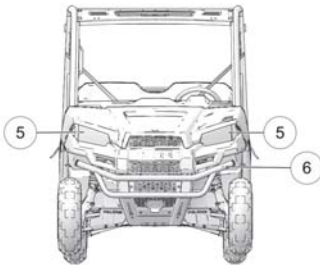
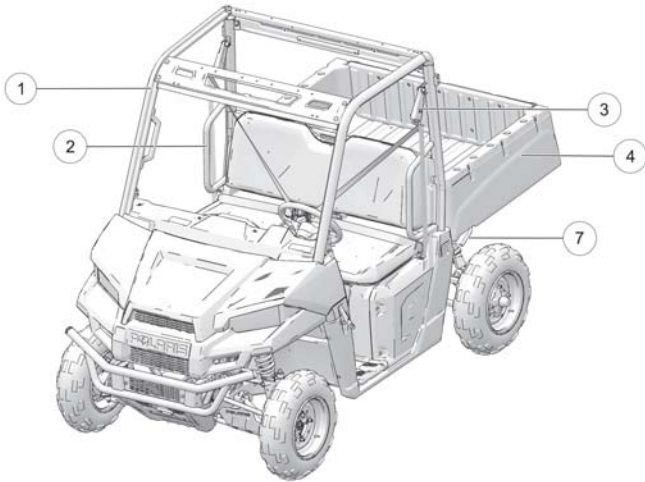

- ① ROPS Frame
- ② Hip Bars
- ③ Seat Belt
- ④ Cargo Box
- ⑤ Headlight

- ⑥ Front Bumper/Brush Guard
- ⑦ Cargo Box Release Lever
- ⑧ Tailgate Latches
- ⑨ Taillights
- ⑩ Receiver Hitch

CONSOLE

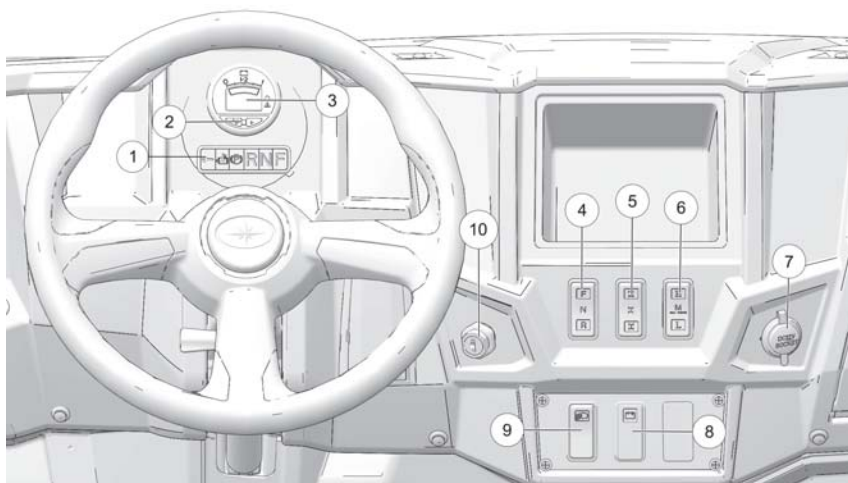

- ① Indicator Lights
- ② Hour Meter
- ③ Battery Discharge Indicator
- ④ Direction Selector
- ⑤ AWD Switch
- ⑥ Drive Mode Switch
- ⑦ 12V Auxiliary Outlet
- ⑧ Charge Status Indicator
- ⑨ Headlight Switch
- ⑩ Key Switch

BATTERY DISCHARGE INDICATOR

The battery discharge indicator displays the amount of charge removed (used) from fully charged batteries. When the batteries are fully charged, the gauge will display 100%. The charge status indicator will be solid green.



NOTE

Avoid discharging the batteries below 20% on the discharge indicator.

INDICATOR PANEL LIGHTS

The indicator lights activate when the key is in the ON position.

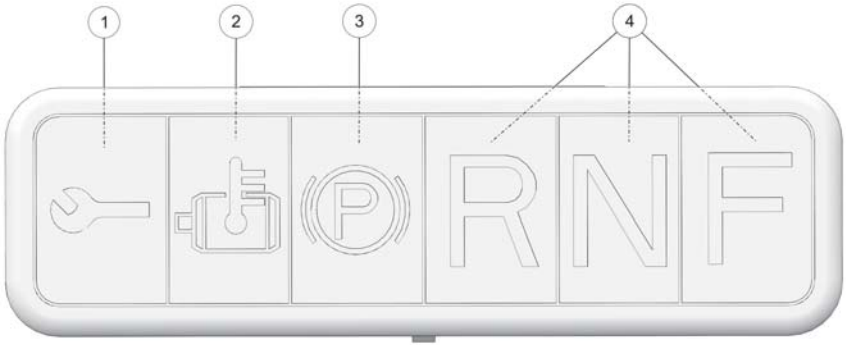

	INDICATOR	STATUS	INDICATES
①	Malfunction	Steady	Electrical malfunction (flash sequence on controller indicates type)
②	Park Brake	Steady	Engaged park brake
③	Gear Position	Steady	Selected gear
④	Motor/ Controller High Temperature	Flashing	Reduced performance due to elevated temperature
		Steady	Power delivery terminated to protect against overheating
		<i>If either occurs, stop the vehicle and turn the key off. Allow the motor and controller to cool adequately before operating.</i>	

FEATURES AND CONTROLS

HOURLY METER

The hour meter records and displays the hours of actual vehicle movement since manufacture.

CHARGE STATUS INDICATOR

When charging the batteries, the charge status indicator light flashes and changes color to indicate the status of the charge. Refer to the table below.

Color	Indication	Code Definition
Green	Solid	Charge is complete, charger is in maintenance mode.
Green	Fast Flash	Less than 80% of charge is completed.
Green	Slow Flash	More than 80% of charge is completed.
Amber	Flashing	Power mode is reduced, low AC voltage or high internal charger temperature exists; open hood to improve air flow.
Red	Flashing	Charger error exists; reset charger power and refer to Troubleshooting section of owner's manual

SWITCHES

KEY SWITCH

Turn the key to the ON position to activate the electrical circuits. Turn the key to the OFF position to disable all electrical circuits. The key can be removed from the switch when it is in the OFF position.

DRIVE MODE SWITCH

CAUTION

Changing the drive mode switch position while driving could result in an automatic increase or decrease in speed without a change to accelerator pedal pressure.

Press the top of the switch to select high mode. Use high mode for most trail-riding conditions. The vehicle will operate at speeds up to 25 MPH (40 km/h).

Press the bottom of the switch to select low mode. Low mode is recommended for short-term operation in extreme load conditions. Use low mode when towing, hauling loads or maneuvering over obstacles. Speed will be limited to a maximum of 10 MPH (16 km/h) and regenerative braking increases to improve control in aggressive terrain. Return the mode switch to high mode for normal operation.



Move the switch to the center position to select the maximum range mode. Use this mode to operate the vehicle a greater distance or for a longer time period. This mode limits both speed and torque to obtain the maximum driving range.

MODE	MAXIMUM SPEED	TORQUE (PERCENT OF MAXIMUM TORQUE)	DECELERATION	APPLICATION
High	25 MPH (40 km/h)	70%	Minimum	Trail riding
Max Range	15 MPH (24 km/h)	50%	Minimum	Whenever possible, to maximum driving range of battery pack
Low	10 MPH (16 km/h)	100%	Maximum	owing, hauling loads, driving on steep hills or aggressive terrain

FEATURES AND CONTROLS

DIRECTION SELECTOR SWITCH

When the direction selector is in the center position, the vehicle is in neutral. The vehicle will not move if the accelerator pedal is depressed. Push the top of the switch to choose forward operation. Push the bottom of the switch to choose reverse operation. If the switch is changed while the accelerator pedal is depressed, the vehicle will not move in the new direction until the pedal is released, then depressed again.



TIP

The malfunction light will illuminate after reversing direction if you fail to release the throttle pedal after changing the switch.

AWD SWITCH

The AWD switch has three positions: All Wheel Drive (AWD), Differential Lock/Two Wheel Drive (2WD) and Off (1WD/Turf Mode).

Press the top of the switch to engage All Wheel Drive (AWD). See page 42 for operating instructions.

Move the switch to the center position to lock the differential and operate in two wheel drive (2WD).

Press the bottom of the switch to unlock the differential and allow the rear drive wheels to operate independently (1WD). This mode of operation is well suited to turf driving or when active traction is not needed.

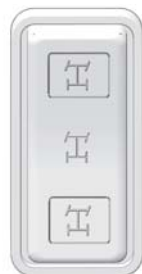

HEADLIGHT SWITCH

Press the top of the switch to turn the headlights on. Press the bottom of the switch to turn the headlights off.



BATTERIES

This vehicle is equipped with eight 12-volt batteries that supply the power needed to operate the vehicle. The batteries are located under the seat. See page 63 for battery access instructions.

Always observe all battery safety warnings and safe handling procedures as outlined on vehicle safety labels and in this manual.

BATTERY HANDLING PRECAUTIONS

- Always make sure that all electrical accessories are grounded directly to the negative (-) post on the terminal board. Never use the chassis or body as a ground connection.
- Always keep battery terminals and connections clean and free of corrosion at all times.
- Always maintain a full charge on the batteries. For best battery life, avoid discharging the batteries more than 80%.
- Make sure new batteries are fully charged before using.
- New deep cycle batteries need to be cycled several times before reaching full capacity (50- 125 cycles, depending on type). Capacity will be limited during this time.
- Make sure vent caps are installed properly and securely during vehicle operation and battery charging.
- Recharge batteries fully at the end of each day the vehicle is operated, allowing adequate time for the charger to complete its charge cycle. The batteries in this vehicle do not have a “memory effect”. Frequent charging will extend their life.
- Avoid charging at temperatures above 120° F. (49° C.) ambient air temperature. Closed, unvented storage buildings often exceed this temperature when exposed to direct sunlight.
- Never connect an auxiliary battery to the factory-installed DC-to-DC converter. If more than 10 amps are needed for accessories, always install the POLARIS-approved auxiliary accessory battery kit.

FEATURES AND CONTROLS

- Never connect a 12-volt accessory directly to the batteries. Always connect any powered accessory to a 12-volt auxiliary outlet or terminal board.
- Never connect jumper cables to any of the batteries of this vehicle.
- Use only insulated tools when working in the battery compartment.

BATTERY CONDITIONING

New batteries cannot initially hold all of their capacity. The approximate capacity of the battery pack increases as the number of charge cycles increases.

Number of Charge Cycles:	New	15	30	45
Percentage of Full Capacity	80%	90%	95%	100%

AMBIENT TEMPERATURE IMPLICATIONS ON BATTERIES

- Battery range decreases as ambient temperature decreases. This can affect the range by up to 30%.
- Batteries discharge when left uncharged. They can discharge up to 13% per month (higher rates in warmer climates) with the key off and much faster if the key is left on.
- Batteries can freeze if left uncharged at low ambient temperatures.

Percent Charged	100%	50%	0%
Approx. Freezing Point	-60° F (-51° C)	0° F (-18° C)	25° F (-4° C)

CHARGER OPERATION

Open the hood and any door enclosures or zippers. This will decrease charger temperature, which allows it to operate more efficiently, and shorten charge times. See pages 61-62 for charging procedures.

1. Always use extension cords with the appropriate ratings for the country in which it is used. In North America this is a UL rating. The cords must also be rated for the conditions in which they are used, such as being rated for protection from oil in a garage or workshop environment.
2. Use the proper cord wire gauges for the cord length used.

Length:	<25 ft (7.5 m)	<50 ft (15 m)	<100 ft (30 m)
Gauge:	16AWG (1.5mm ²)	14AWG (2.5mm ²)	10AWG (6.0mm ²)

BATTERY OPERATION RANGE

Range is significantly affected by tire pressure, alignment, terrain and driving style. Always maintain proper tire pressure as specified on safety labels.

MAIN POWER CONNECTOR

NOTE

Damage to electrical connections and components will occur if they are unplugged before the main power connector is disconnected. Always disconnect the main power connector before servicing or unplugging any electrical components.

When disconnected, the main power connector disconnects the battery pack from all electrical components, with the exception of the contactor. After servicing the vehicle, the main power connector should be the last connection to be made.

The main power connector is located under the seat on the driver's side of the controller tray, adjacent to the main line contactor. To disconnect, unplug the connector.

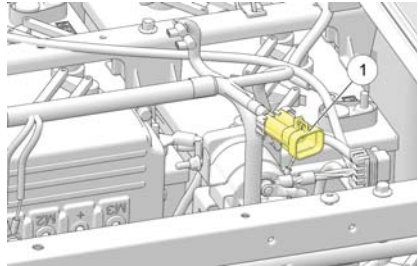

To disconnect the battery pack from the vehicle completely, disconnect the main power connector, then remove the B+ wire from the battery terminal.

WARNING

Insulate any tools used within the battery area to prevent sparks or battery explosion caused by shorting the battery terminals or wiring. Remove the batteries, or cover the exposed terminals with an insulating material.

FEATURES AND CONTROLS

TRAILER RECEIVER HITCH BRACKET

This vehicle is equipped with a receiver hitch bracket for a trailer hitch. Trailer towing equipment is not supplied with this vehicle.

To avoid injury and property damage, always heed the warnings and towing capacities.

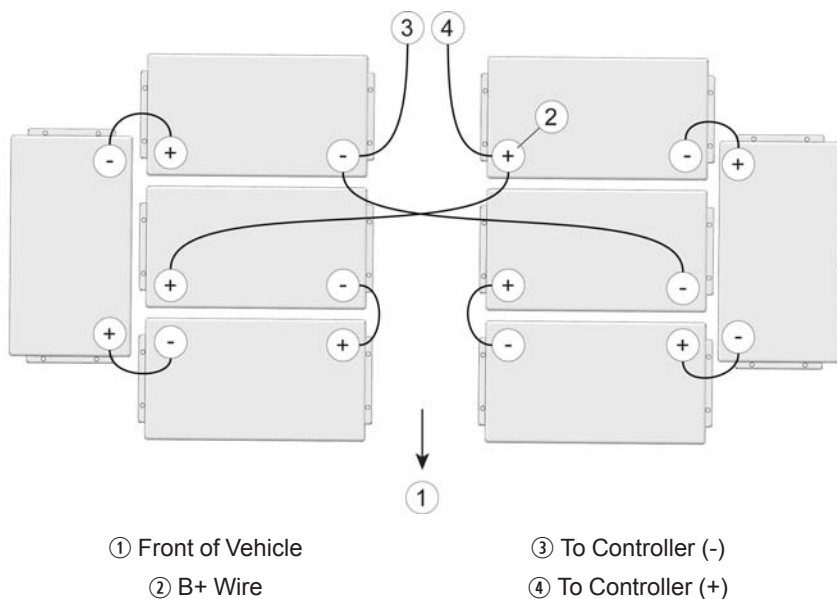

GEAR SELECTOR

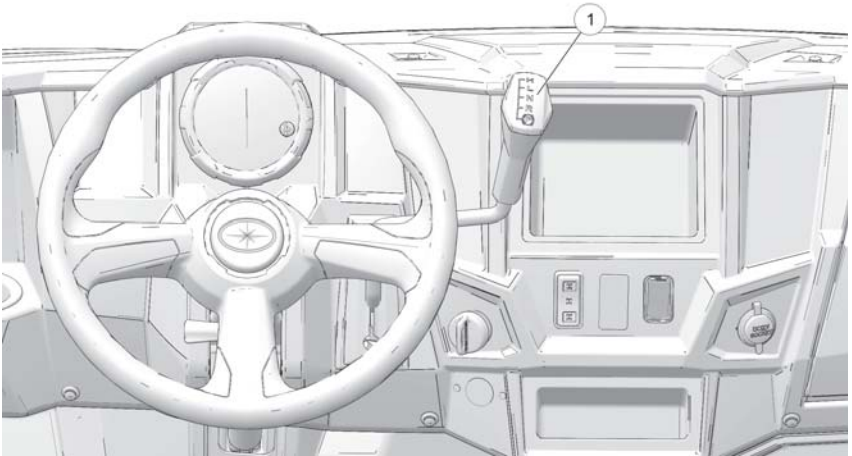

To change gears, stop the vehicle, and with the engine idling, move the lever ① to the desired gear. Do not attempt to shift gears with engine speed above idle or while the vehicle is moving.

H: High Gear
 L: Low Gear
 N: Neutral
 R: Reverse
 P: Park



Low gear is the primary driving range for the RANGER. High gear is intended for use on hard-packed surfaces with light loads. Whenever the vehicle is left unattended, always place the transmission in PARK.

TIP

Maintaining shift linkage adjustment is important to assure proper transmission function. Your POLARIS dealer can assist in resolving any shifting problems.

FEATURES AND CONTROLS

NOTICE

Do not attempt to shift the transmission while the vehicle is moving or damage to the transmission could result. Always shift when the vehicle is stationary and the engine is at idle.

USING LOW GEAR

Always shift into low gear for any of the following conditions.

- Operating in rough terrain or over obstacles
- Loading the vehicle onto a trailer
- Towing heavy loads

PARK BRAKE LEVER (IF EQUIPPED)

Always apply the service brakes before engaging or releasing the park brake. To help prevent the vehicle from rolling, set the park brake when parking the vehicle. When the park brake is set and the park brake indicator is illuminated, engine speed is limited. If the accelerator is applied, this limiting feature prevents operation, which protects the park brake pads from excessive wear.

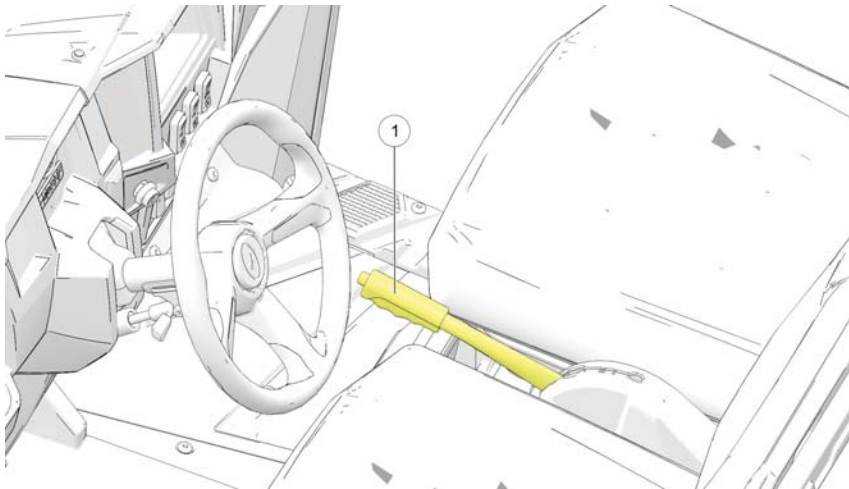

TIP

This feature will not operate properly if the park brake connector or switch (under the hood) malfunctions or becomes disconnected, or if the switch has moved. Check for disconnection, then see your dealer or other qualified service person promptly if this feature fails to operate properly.

1. To set the park brake, apply the brakes.
2. Pull the park brake lever upward as far as possible.
3. To release the park brake, apply the brakes. Press the park brake release inward and move the lever downward as far as possible.

STEERING WHEEL

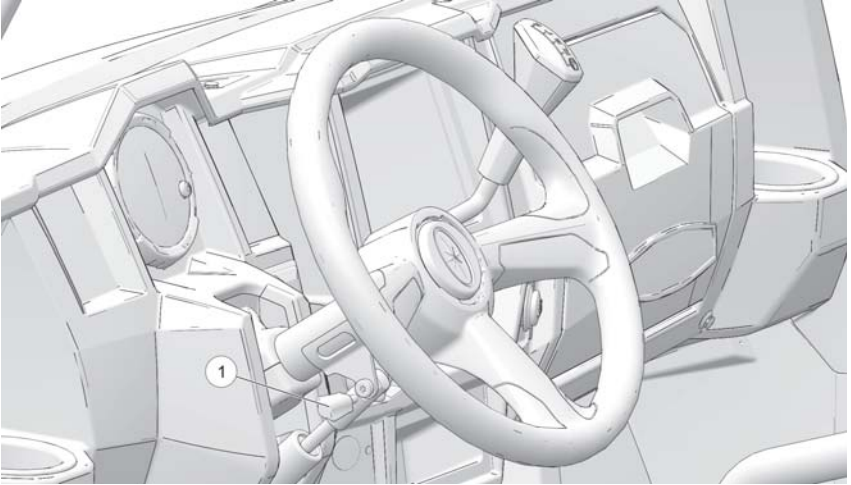

The steering wheel can be tilted upward or downward for rider preference.

Lift and hold the steering wheel adjustment lever while moving the steering wheel upward or downward. Release the lever when the steering wheel is at the desired position.

Always make sure the steering wheel position does not impede proper operation of the brake pedal, throttle pedal and all other controls.

FEATURES AND CONTROLS

ELECTRONIC POWER STEERING (EPS)

Electronic power steering (if equipped) engages when the ignition key is turned to the ON position. EPS remains engaged whether the vehicle is moving or idle. To conserve battery power, the EPS will shut down 5 minutes after the engine is stopped if the key remains in the ON position. The EPS warning indicator will illuminate to indicate the EPS has shut down. Turn the key off and on to reset the unit. If the light remains on after starting the engine, the EPS system is inoperative. Your POLARIS dealer can assist.

FOOT PEDALS

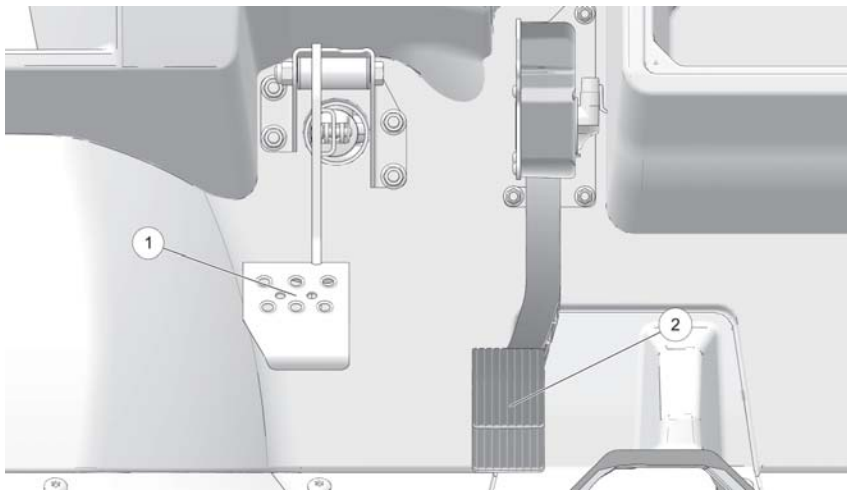

BRAKE PEDAL

Depress the brake pedal ① to slow or stop the vehicle. Apply the brakes while starting the engine.

When the brake pedal is depressed, the brake light comes on. Check the brake light before each ride.

1. Turn the ignition switch to the ON position.
2. Apply the brakes. The brake light should come on after about 10 mm (0.4 in.) of pedal travel.

ACCELERATOR PEDAL

The accelerator pedal ② will function only when the key is ON and the direction selector switch is set to either forward or reverse. To begin moving or to increase vehicle speed, gradually push the accelerator pedal toward the floor. Holding the accelerator pedal down continuously will accelerate the vehicle to the maximum speed.

To slow the vehicle, release the accelerator pedal. Electric motor braking provides braking when the pedal is released. For additional speed control or to stop the vehicle, apply the service brakes.

SEATS

SEAT REMOVAL

Pull up on the front of the seat and slide it toward the front of the vehicle. Install the seat by sliding the tabs into the rear of the seat base. Push down firmly on the front of the seat until the pins are fully seated into the grommets.

SEAT BELTS



This vehicle is equipped with three-point lap and diagonal seat belts for the operator and passenger. Always make sure the seat belts are secured for all riders before operating. The driver's seat belt is equipped with a seat belt interlock. Vehicle speed will be limited to 15 MPH (24 km/h) if the seat belt is not secured.

The center of the seat is NOT equipped with a seat belt. Never allow a passenger to ride between the operator and passenger seats.

FEATURES AND CONTROLS

WARNING

Falling from a moving vehicle could result in serious injury or death. Always fasten your seat belt securely before operating or riding in the vehicle.

To wear the seat belt properly, follow this procedure:

1. For 3-point belts, pull the seat belt latch ① downward and across your chest toward the buckle at the inner edge of the seat. The belt should fit snugly across your hips and diagonally across your chest. Make sure the belt is not twisted.
2. Push the latch plate ① into the buckle ② until it clicks.
3. Release the strap, it will self tighten.
4. To release the seat belt, press the square red button in the buckle's center.

SEAT BELT INSPECTION

Inspect all seat belts for proper operation before each use of the vehicle.

1. Push the latch plate into the buckle until it clicks. The latch plate must slide smoothly into the buckle. A click indicates that it's securely latched.
2. Push the red release latch in the middle of the buckle to make sure it releases freely.
3. Pull each seat belt completely out and inspect the full length for any damage, including cuts, wear, fraying or stiffness. If any damage is found, or if the seat belt does not operate properly, have the seat belt system checked and/or replaced by an authorized dealer.
4. To clean dirt or debris from the seat belts, sponge the straps with mild soap and water. Do not use bleach, dye or household detergents. Rinse the entire length of the belt webbing. Use a garden hose to flush out the retractor and latch housings regularly.

CHARGING CORD

The charging cord is located under the hood on the right side of the vehicle. See page 62 for charging instructions.

AUXILIARY OUTLET

The 12-volt receptacle can be used to power accessories, but is limited to 10 amps (the terminal board and 12-volt outlet are fused together at 10 amps).

AUXILIARY 12-VOLT TERMINAL BOARD

The 12-volt terminal board is located under the hood. It contains constant 12-volt, switched 12-volt and ground terminals that can be used to power auxiliary lights and accessories. The terminals are limited to 10 amps.

ROLLOVER PROTECTIVE STRUCTURE (ROPS)

The Rollover Protective Structure (ROPS) on this vehicle meets OSHA 1928.53 rollover performance requirements. Always have your authorized POLARIS dealer thoroughly inspect the ROPS if it ever becomes damaged in any way.

No device can assure occupant protection in the event of a rollover. Always follow all safe operating practices outlined in this manual to avoid vehicle rollover.

NOTE

Vehicle rollover could cause severe injury or death. Always avoid operating in a manner that could result in vehicle rollover.

OPERATION

WARNING

Failure to operate the vehicle properly can result in a collision, loss of control, accident or rollover, which may result in serious injury or death. Read and understand all safety warnings outlined in the safety section of this owner's manual.

VEHICLE BREAK-IN PERIOD

The break-in period for your new vehicle is the first 20 hours of operation, or the time it takes to use the first 2 tanks full of gasoline. No single action on your part is as important as a proper break-in period. Careful treatment of a new engine will result in more efficient performance and longer life for the engine. Perform the following procedures carefully.

NOTICE

Excessive heat build-up during the first 3 hours of operation will damage close-fitted engine parts and drive components. Do not operate at full throttle or high speeds during the first 3 hours of use.

ENGINE AND DRIVETRAIN BREAK-IN

1. Complete the New Operator Driving Procedures.
2. Avoid aggressive use of the brakes.
3. Vary throttle positions.
4. Pull only light loads.
5. Perform regular checks on fluid levels, controls and areas outlined on the daily pre-ride inspection checklist.
6. Check fluid levels of transmission and all gearcases after the first 25 hours of operation and every 100 hours thereafter.

OPERATION

BRAKE SYSTEM BREAK-IN

Apply only moderate braking force for the first 50 stops. Aggressive or overly forceful braking when the brake system is new could damage brake pads and rotors.

PVT BREAK-IN (CLUTCHES/BELT)

A proper break-in of the clutches and drive belt will ensure a longer life and better performance. Break in the clutches and belt by operating at slower speeds during the break-in period as recommended. Pull only light loads. Avoid aggressive acceleration and high speed operation during the break-in period.

If a belt fails, always clean any debris from the PVT intake and outlet duct and from the clutch and engine compartments when replacing the belt.

PRE-RIDE INSPECTION

Failure to inspect and verify that the vehicle is in safe operating condition before operating increases the risk of an accident. Always inspect the vehicle before each use to make sure it's in safe operating condition.

ITEM	REMARKS	PAGE
Brake system/pedal travel	Ensure proper operation	page 42 page 81
Brake fluid	Ensure proper level	page 81
Front suspension	Inspect, lubricate if necessary	page 77
Rear suspension	Inspect, lubricate if necessary	page 77
Steering	Ensure free operation	page 41
Tires	Inspect condition and pressure	page 84
Wheels/fasteners	Inspect, ensure fastener tightness	page 84
Frame nuts, bolts, fasteners	Inspect, ensure tightness	-
Accelerator	Ensure proper operation	-
Headlamps	Check operation, apply POLARIS dielectric grease when lamp is replaced	page 86
Brake light/tail lamps	Check operation	-
Seat Latch	Push down on the seat back to ensure the latch is secure	-
Seat Belt	Check length of belt for damage, check latches for proper operation	page 43

ITEM	REMARKS	PAGE
Batteries	Ensure full charges, proper water levels, clean terminals	page 35
Battery cables	Inspect for proper cable routing and secure connections	page 35

SAFE OPERATION PRACTICES

1. Visit the Recreational Off-Highway Vehicle Association web site and take the free on-line training course. Complete the recommended safety training before operating this vehicle. Visit www.rohva.org or call 866-267-2751.
2. Do not allow anyone under 16 years of age or without a valid driver's license to operate this vehicle.
3. Never carry a passenger on this vehicle.
4. Engine exhaust fumes are poisonous. Never start the engine or let it run in an enclosed area.
5. Never operate with accessories not approved by POLARIS for use on this vehicle.
6. Operate this vehicle off-road only. Never operate this vehicle on any public street, road or highway, including dirt and gravel roads (unless designated for off-highway use).
7. Use caution and drive at reduced speeds in conditions of reduced visibility such as fog, rain and darkness. Clean headlights frequently and replace burned out headlamps promptly.
8. Always operate at a speed that's appropriate for the terrain, the visibility and operating conditions and your skills and experience. Never operate at excessive speeds. Never attempt wheelies, jumps, or other stunts. Keep both hands on the steering wheel during operation.
9. Never consume alcohol or drugs before or while operating this vehicle.
10. Always use the size and type of tires specified for your vehicle. Always maintain proper tire pressure.
11. Never operate a damaged vehicle. After any rollover or accident, have a qualified service dealer inspect the entire machine for possible damage.
12. Never operate the vehicle on a frozen body of water unless you have first verified that the ice is sufficiently thick to support the weight and moving force of the vehicle, you and your cargo, together with any other vehicles in your party.
13. Do not touch hot exhaust system components. Always keep combustible materials away from the exhaust system.
14. Always remove the ignition key when the vehicle is not in use to prevent unauthorized use.

OPERATION

KNOW YOUR RIDING AREA/TREAD LIGHTLY

Familiarize yourself with all laws and regulations concerning the operation of this vehicle in your area. Respect the environment in which you ride your vehicle.

Find out where the designated riding areas are by contacting your POLARIS dealer, a local riding club, or local officials.

Help keep our trails open for recreational vehicle use. As an off-road enthusiast, you represent the sport and can set a good example (or a poor example) for others to follow. Tread lightly. Operate with respect for the terrain, avoid littering, and always stay on the designated trails.

TRAIL ETIQUETTE

Always practice good etiquette when riding. Allow a safe distance between your vehicle and other vehicles operating in the same area. Communicate to oncoming operators by signaling the number of vehicles in your group. When stopping, move your vehicle to the edge of the trail as far as possible to allow others to pass safely.

DRIVING PROCEDURES

NOTE

Depictions of the vehicle shown in the "Driving Procedures" section represent the entire ACE product line. The vehicle shown may not depict the model you purchased and are intended for reference use only.

NEW OPERATOR DRIVING PROCEDURES

1. Read and understand the owner's manual and all warning and instruction labels before operating this vehicle.
2. Visit the Recreational Off-Highway Vehicle Association web site and take the free on-line training course. Visit www.rohva.org or call 866-267-2751. Hands-on training is also available through ROHVA.
3. Perform the pre-ride inspection.
4. Do not tow or carry cargo during this period.
5. Select an open area that allows room to familiarize yourself with vehicle operation and handling.
6. The driver must wear helmet, eye protection, gloves, long-sleeve shirt, long pants, over-the-ankle boots and seat belt at all times.
7. Sit in the driver's seat and fasten the seat belt.
8. Always make sure all cab doors are closed and latched when riding in this vehicle.
9. Place the transmission in PARK.
10. Start the engine.

11. Apply the brakes and shift into low gear.
12. Check your surroundings and determine your path of travel.
13. Keeping both hands on the steering wheel, slowly release the brakes and depress the throttle with your right foot to begin driving.
14. Drive slowly at first. On level surfaces, practice starting, stopping, turning, maneuvering, using the throttle and brakes and driving in reverse. Learn how the vehicle handles when making both left and right turns at a slow speed.

WARNING

Operating in TURF mode (if equipped) when on sloped, uneven, or loose terrain could cause loss of control and result in serious injury or death. One rear wheel may slip and lose traction or may lift up and grab when it touches the ground again.

15. Increase speed only after mastering all maneuvers at a slow speed.
16. After you become skilled at making turns and begin to operate at faster speeds, follow these precautions:
 - Avoid sharp turns.
 - Never turn while applying heavy throttle.
 - Never make abrupt steering maneuvers.
 - Operate at speeds appropriate for your skills, the conditions and the terrain.
 - DO NOT do power slides, “donuts”, jumps or other driving stunts.

DRIVING WITH A PASSENGER

1. Perform the pre-ride inspection.
2. Make sure all passengers are at least 12 years of age and tall enough to comfortably and safely sit in a passenger seat with the seat belt secured, put both feet on the floor and grasp the hand hold.
3. Make sure all passengers are wearing helmet, eye protection, gloves, long-sleeve shirt, long pants and over-the-ankle boots.
4. Make sure all passengers secure their seat belt.
5. Make sure all cab nets (or doors) are properly secured.
6. Do not carry more than the recommended number of passengers for your vehicle.
7. Allow a passenger to ride only in a passenger seat.
8. Slow down. Always travel at a speed appropriate for your skills, your passengers' skills, and operating conditions. Avoid unexpected or aggressive maneuvers that could cause discomfort or injury to a passenger.
9. Vehicle handling may change with a passenger and/or cargo on board. Allow more time and distance for braking.

OPERATION

10. Always follow all operating guidelines as outlined on safety labels and in this manual.

DRIVING ON SLIPPERY SURFACES

WARNING

Skidding or sliding can cause loss of control or rollover (if tires regain traction unexpectedly). When operating on slippery surfaces such as ice or loose gravel, reduce speed and use extra caution to reduce the chance of skidding or sliding out of control. Do not operate on excessively slippery surfaces.

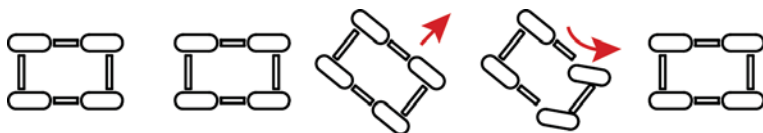

When driving on slippery surfaces such as wet trails, loose gravel, or ice, be alert for the possibility of skidding and sliding. Follow these precautions when encountering slippery conditions:

1. Do not operate on excessively rough, slippery or loose terrain.
2. Slow down before entering slippery areas.
3. Maintain a high level of alertness, reading the trail and avoiding quick, sharp turns, which can cause skids.
4. Engage all-wheel drive before wheels begin to lose traction.

NOTICE

Severe damage to the drive train may occur if the AWD is engaged while the wheels are spinning. Always allow the wheels to stop spinning before engaging AWD.

5. Correct a skid by turning the steering wheel in the direction of the skid. *Never apply the brakes during a skid.*

DRIVING OVER OBSTACLES

Follow these precautions when operating over obstacles:

1. Always check for obstacles before operating in a new area.
2. Look ahead and learn to read the terrain. Be constantly alert for hazards such as logs, rocks and low hanging branches.
3. Travel slowly and use extra caution when operating on unfamiliar terrain. Not all obstacles are immediately visible.
4. Avoid operating over large obstacles such as large rocks and fallen trees. If unavoidable, use extreme caution and operate slowly.
5. Always have all passengers dismount and move away from the vehicle before operating over an obstacle that could cause a rollover.

DRIVING UPHILL

Whenever traveling uphill, follow these precautions:

1. Avoid excessively steep hills.
2. ADC Models: Always operate in low gear and engage ADC 4X4 before ascending or descending a hill.
3. Always travel straight uphill.
4. Keep both feet on the floor.
5. Always check the terrain carefully before ascending any hill. Never climb hills with excessively slippery or loose surfaces.
6. Proceed at a steady rate of speed and throttle opening. Never open the throttle suddenly.
7. Never go over the crest of a hill at high speed. An obstacle, a sharp drop, or another vehicle or person could be on the other side of the hill.

DRIVING DOWNHILL

When driving downhill, follow these precautions:

1. Avoid excessively steep hills.
2. ADC Models: Always operate in low gear and engage ADC 4X4 before ascending or descending a hill.
3. Drive straight downhill. Avoid descending a hill at an angle, which would cause the vehicle to lean sharply to one side. Travel straight downhill when possible.
4. Slow down.
5. Apply the brakes slightly to aid in slowing.

OPERATION

DRIVING ON A SIDEHILL (SIDEHILLING)

Driving on a sidehill is not recommended. Improper procedure could cause loss of control or rollover. Avoid crossing the side of any hill unless absolutely necessary.

If crossing a sidehill is unavoidable, follow these precautions:

1. Slow down.
2. Exercise extreme caution.
3. Avoid crossing the side of a steep hill.
4. ADC Models: Always operate in low gear and engage ADC 4X4 before ascending or descending a hill.

DRIVING THROUGH WATER

Your vehicle can operate through water up to a maximum recommended depth equal to the floorboards.

NOTE

Serious damage can occur to the electrical system and batteries if the vehicle is operated in water deeper than the floorboards.

Follow these procedures when operating through water:

1. Determine water depths and current before entering water.
2. Choose a crossing where both banks have gradual inclines.
3. Proceed slowly, avoiding rocks and obstacles.
4. Avoid operating through deep or fast-flowing water.

WARNING

The large tires on your vehicle may cause the vehicle to float in deep or fast-flowing water, which could result in loss of control and lead to serious injury or death. Never cross deep or fast-flowing water with your vehicle

5. After leaving water, always dry the brakes by applying light pressure to the pedal repeatedly until braking action is normal.

DRIVING IN REVERSE

Follow these precautions when operating in reverse:

1. Always check for obstacles or people behind the vehicle. Always inspect left and right fields of vision before backing.
2. Always avoid backing downhill.
3. Back slowly.
4. Apply the brakes lightly for stopping.
5. Avoid turning at sharp angles.
6. Never open the throttle suddenly.

PARKING THE VEHICLE

To park the vehicle, do the following:

1. Apply the brakes. Stop the vehicle on a level surface.
2. When parking inside a garage or other structure, be sure that the structure is well ventilated and that the vehicle is not close to any source of flame or sparks, including any appliance with pilot lights.
3. Place the transmission in PARK.
4. Turn the engine off.
5. Slowly release the brake pedal and make sure the transmission is in PARK before exiting the vehicle.
6. Engage the park brake (if equipped).
7. Remove the ignition switch key to prevent unauthorized use.

PARKING ON AN INCLINE

Avoid parking on an incline if possible. If it's unavoidable, follow these precautions:

1. Apply the brakes.
2. Place the transmission in PARK.
3. Engage the parking brake (if equipped).
4. Turn the engine off.
5. Slowly release the brake pedal and make sure the transmission is in PARK before exiting the vehicle.
6. Engage the park brake (if equipped).
7. Block the rear wheels on the downhill side.

OPERATION

DRIVE MODE

Press the top of the rocker switch to engage All Wheel Drive (AWD). Once enabled, the AWD remains enabled until the switch is turned off.

The AWD switch may be turned on or off while the vehicle is moving. When the AWD switch is on, the front gearcase will automatically engage any time the rear wheels lose traction. When the rear wheels regain traction, the front gearcase will automatically disengage.

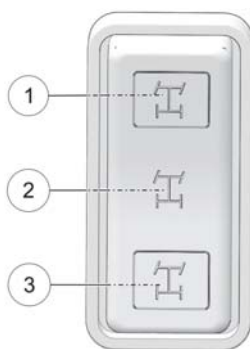

- ① All-wheel Drive (AWD)
- ② Two-wheel Drive (2WD)
- ③ One-wheel Drive (Turf Mode)

TIP

AWD will not engage initially until speed is less than 5 MPH (8 km/h).

Engage the AWD before getting into conditions where front wheel drive may be needed. If the rear wheels are spinning, release the accelerator before switching to AWD.

NOTE

Switching to AWD while the rear wheels are spinning may cause severe drive train damage. Always switch to AWD while the rear wheels have traction or are at rest.

LOCKING THE DIFFERENTIAL

NOTE

Damage to the differential can occur if it is engaged while the vehicle is traveling at high speeds or while the rear wheels are spinning. Slow the vehicle to nearly stopped before engaging the differential.

Locking the differential in slippery or low traction conditions helps improve traction. Move the rocker switch to the center position (2WD) to lock the differential and operate in rear wheel drive.

Press the bottom of the switch to unlock the differential and allow the rear drive wheels to operate independently. This mode of operation is well suited to turf driving or whenever aggressive traction is not required.

DISENGAGING AWD

Move the AWD switch to the center or bottom position to disengage AWD.

If the switch is turned off while the front gearcase is moving, it will not disengage until the rear wheels regain traction.

In some situations, the front gearcase may remain locked after turning the AWD switch off. If this occurs, you may notice increased steering effort and some vehicle speed restriction. Perform the following procedure to unlock the front gearcase.

1. Stop the vehicle.
2. Move the direction selector to reverse. Operate in reverse for at least 10 feet (3 m).
3. Stop completely.
4. Move the direction selector to forward and drive forward.
5. If the front gearcase remains locked after following these instructions, return the vehicle to your dealer for service.

HAULING CARGO

WARNING

Overloading the vehicle or carrying or towing cargo improperly can alter vehicle handling and may cause loss of control or brake instability. Always follow these precautions when hauling cargo:

Never exceed the stated load capacity for this vehicle.

REDUCE SPEED AND ALLOW GREATER DISTANCES FOR BRAKING WHEN HAULING CARGO.

NEVER EXCEED THE MAXIMUM WEIGHT CAPACITY of the vehicle. When determining the weight you are adding to the vehicle, include the weight of the operator, accessories, loads in the rack or box and the load on the trailer tongue. The combined weight of these items must not exceed the maximum weight capacity.

Always load the cargo box with the load as far forward and as low as possible. When operating over rough or hilly terrain, reduce speed and cargo to maintain stable driving conditions.

Always operate the vehicle with extreme care when hauling or towing loads. Slow down and drive in the lowest gear available.

SECURE ALL LOADS BEFORE OPERATING. Unsecured loads can create unstable operating conditions, which could result in loss of control of the vehicle.

OPERATE ONLY WITH STABLE AND SAFELY ARRANGED LOADS. When handling off-centered loads that cannot be centered, securely fasten the load and operate with extra caution. Always attach the tow load to the hitch point designated for your vehicle.

HEAVY LOADS CAN CAUSE BRAKING AND CONTROL PROBLEMS. Use extreme caution when applying brakes with a loaded vehicle. Avoid terrain or situations that may require backing downhill.

USE EXTREME CAUTION when operating with loads that extend over the rack sides. Stability and maneuverability may be adversely affected, causing vehicle rollover.

DO NOT TRAVEL FASTER THAN THE RECOMMENDED SPEEDS. Vehicle should never exceed 10 MPH (16 km/h) while towing a load on a level grass surface. Vehicle speed should never exceed 5 MPH (8 km/h) when towing loads in rough terrain, while cornering, or while ascending or descending a hill.

Never exceed 43 MPH (70 km/h) if total payload exceeds 335 lbs. (152 kg). Carrying a passenger in the cargo box could result in a fall from the vehicle or contact with moving components. Never allow a passenger to ride in the cargo box.

Your vehicle has been designed to carry or tow specific capacities. Reduce speed and allow a greater distance for braking when carrying cargo.

Loads should be centered and carried as low as possible in the box. For stability on rough or hilly terrain, reduce both speed and cargo. Exercise caution if the cargo load extends over the side of the box.

Always read and understand the load distribution warnings listed on warning labels and in this manual. Never exceed the maximum capacities specified for your vehicle.

DUMPING THE CARGO BOX

To dump the cargo box, do the following:

1. Select a level site to dump the cargo box. Do not attempt to dump or unload the vehicle while parked on an incline.
2. Apply the brakes.
3. Set the park brake (if equipped).
4. Turn the key to the off position.
5. Dismount vehicle.
6. Ensure that the cargo is positioned evenly or toward the front of the cargo box.
7. Release the tailgate latches.

WARNING

If the weight distribution on the box is located toward the rear of the box when the release lever is pulled forward, the box may dump unexpectedly and cause serious injury to the operator or bystanders. Never operate the dump lever without ensuring that the load is positioned evenly or at the front of the box.

8. Stand clear and pull up on the cargo box release lever.
9. Lift the front of the cargo box to dump the cargo.
10. Lower the cargo box and push down securely to latch.
11. Close the tailgate.

WARNING

Operating the vehicle while the cargo box is raised could result in severe injury. The box could close unexpectedly and cause injury to the driver or passenger. The rear tires will also catch the rear of a raised box, damaging the vehicle and creating hazardous driving conditions. Never operate this vehicle with the cargo box in the raised position.

OPERATION

TOWING LOADS

WARNING

Towing improperly can alter vehicle handling and may cause loss of control or brake instability.

Always follow these precautions when towing:

1. Never load more than 150 lbs. (68.1 kg) tongue weight on the towing bracket.
2. When towing a disabled vehicle, place the disabled vehicle's transmission in neutral. Do not operate the vehicle faster than 10 MPH (16 km/h) when towing.
3. Towing a trailer increases braking distance. Do not operate the vehicle faster than 10 MPH (16 km/h) when towing.
4. Do not tow more than the recommended weight for the vehicle.
5. Attach a trailer to the trailer hitch bracket only. Do not attach a trailer to any other location, which could result in loss of control of the vehicle.
6. The total load (operator, accessories, cargo and weight on hitch) must not exceed the maximum weight capacity of the vehicle.

TOTAL TOWED LOAD WEIGHT (LEVEL GROUND)	TOTAL TOWED LOAD WEIGHT (15° GRADE)	TOTAL HITCH VERTICAL WEIGHT	MAXIMUM TOWING SPEED
1500 lbs. (681 kg)	850 lbs. (386 kg)	150 lbs. (68.1 kg)	10 MPH (16 km/h)

TRANSPORTING THE VEHICLE

When transporting the RANGER for a long distance or on public streets, always use a trailer with an approved load rating greater than the RANGER's curb vehicle weight plus any installed accessories or cargo.

Follow these guidelines when transporting the vehicle:

1. Set the park brake.
2. Remove the key to prevent loss.
3. Secure the seat, hood and tailgate latches. Ensure that the seats are attached correctly and are not loose.

WARNING

Cargo and other loose vehicle parts may fly off while transporting this vehicle. Secure or remove all cargo, and inspect the unit for loose parts prior to transport.

4. Always tie the frame of the RANGER to the transporting unit securely with suitable straps.
5. If using an open trailer, remove the windshield (if equipped).
6. Never allow passengers on a trailer or in a trailered vehicle.
7. Reduce speed and drive with caution.

TOWING THE VEHICLE

NOTE

When towing the vehicle, the key **MUST** be in the OFF position or severe motor damage will occur.

Follow these procedures when towing the vehicle:

1. Turn the key to the off position.
2. Always follow these precautions when towing this vehicle:
 - Do not operate faster than 10 MPH (16 km/h).
 - Do not tow on public streets.
 - Do not allow passengers in the towed vehicle.
 - Avoid abrupt starts and stops.
 - Avoid sharp turns and abrupt steering maneuvers.
 - Avoid towing on a hill.

WINCH GUIDE

These safety warnings and instructions apply if your vehicle came equipped with a winch or if you choose to add an accessory winch to your vehicle.

WARNING

Improper winch use can result in SEVERE INJURY or DEATH. Always follow all winch instructions and warnings in this manual.

Your winch may have a cable made of either wire rope or specially designed synthetic rope. The term “winch cable” will be used for either unless noted otherwise.

WINCH SAFETY PRECAUTIONS

1. Read all sections of this manual.
2. Never use alcohol or drugs before or while operating the winch.
3. Never allow children under 16 years of age to operate the winch.
4. Always wear eye protection and heavy gloves when operating the winch.
5. Always keep body, hair, clothing and jewelry clear of the winch cable, fairlead and hook when operating winch.
6. Never attempt to “jerk” a load attached to the winch with a moving vehicle. See the *Shock Loading* section on page 71.
7. Always keep the area around the vehicle, winch, winch cable, and load clear of people (especially children) and distractions while operating the winch.
8. Always turn the vehicle ignition power OFF when it and the winch are not being used.
9. Always be sure that at least five (5) full turns of winch cable are wrapped around the winch drum at all times. The friction provided by this wrapped cable allows the drum to pull on the winch cable and move the load.
10. Always apply your vehicle’s park brake and/or park mechanism to hold the vehicle in place during winching. Use wheel chocks if needed.
11. Always align the vehicle and winch with the load directly in front of the vehicle as much as possible. Avoid winching with the winch cable at an angle to the winching vehicle’s centerline whenever possible.
12. If winching at an angle is unavoidable, follow these precautions:
 - a. Look at the winch drum occasionally. Never let the winch cable “stack” or accumulate at one end of the winch drum. Too much winch cable at one end of the winch drum can damage the winch and the winch cable.
 - b. If stacking occurs, stop winching. Follow step 15 on page 64 to feed and rewind the cable evenly before continuing the winch operation.

WINCH GUIDE

13. Never winch up or down at sharp angles. This can destabilize the winching vehicle and possibly cause it to move without warning.
14. Never attempt to winch loads that weigh more than the winch's rated capacity.
15. The winch motor may become hot during winch use. If you winch for more than 45 seconds, or if the winch stalls during operation, stop winching and permit the winch to cool down for 10 minutes before using it again.
16. Never touch, push, pull or straddle the winch cable while winching a load.
17. Never let the winch cable run through your hands, even if wearing heavy gloves.



18. Never release the clutch on the winch when the winch cable is under load.
19. Never use the winch for lifting or transporting people.
20. Never use the winch to hoist or suspend a vertical load.
21. Never immerse or submerge your winch in water. Your dealer can provide service on your winch if this occurs.
22. Always inspect your winch and winch cable before each use.
23. Never winch the hook fully into the winch. This can cause damage to winch components.
24. Unplug the remote control from the vehicle when the winch is not in use to prevent inadvertent activation and use by unauthorized persons.
25. Never grease or oil the winch cable. This will cause the winch cable to collect debris that will shorten the life of the cable.

WINCH OPERATION

Read the Winch Safety Precautions in the preceding pages before using your winch.

TIP

Consider practicing the operation and use of your winch before you actually need to use it in the field.

⚠ WARNING

Improper winch use can result in SEVERE INJURY or DEATH. Always follow all winch instructions and warnings in this manual.

Each winching situation is unique.

- Take your time to think through the winching you are about to do.
 - Proceed slowly and deliberately.
 - Never hurry or rush during winching.
 - Always pay attention to your surroundings.
 - You may need to change your winching strategy if it is not working.
 - Always remember that your winch is very powerful.
 - There are simply some situations that you and your winch will not be able to deal with. Do not be afraid to ask others to help when this happens.
1. Always inspect the vehicle, winch, winch cable and winch controls for any signs of damage or parts in need of repair or replacement before each use. *Pay particular attention to the first 3 feet (1 meter) of winch cable if the winch is being used (or has been used) for lifting an accessory plow assembly.* Promptly replace any worn or damaged cable.
 2. Never operate a winch or a vehicle in need of repair or service.
 3. Always apply your vehicle's park brake and/ or park mechanism to hold the vehicle in place during winching. Use wheel chocks if needed.

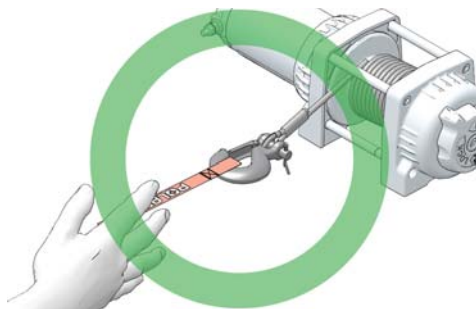

WINCH GUIDE

4. Always use the hook strap when handling the hook.

WARNING

Never put your fingers into the hook. This could lead to SEVERE INJURY.

- Attach the hook itself onto the load or use a tow strap or chain to secure the load to the winch cable.



No



Yes

TIP

A “tow strap” is NOT intended to stretch. A “recovery strap” is designed to stretch.

WARNING

Never use a recovery strap when winching due to the excessive energy that can be released if the winch cable breaks. This can result in SEVERE INJURY or DEATH. See the *Shock Loading* section on page 71.

- Never hook the winch cable back onto itself. This will damage the winch cable and may result in winch cable failure.

⚠ WARNING

Replace the winch cable at the first sign of damage to prevent SEVERE INJURY or DEATH in the event of failure. For your safety, always replace POLARIS winch parts (including the cable) with genuine POLARIS replacement parts available at your authorized POLARIS dealer.

- If possible, keep the winch cable aligned with the centerline of the winching vehicle. This will help the spooling of the winch cable and reduce the load on the fairlead.
- If freeing a stuck vehicle by attaching to a tree, use an item such as a tow strap to avoid damaging the tree during winch operation. Sharp cables and chains can damage and even kill trees. Please remember to TreadLightly® (treadlightly.org).
- Before operating the winch, be sure that the safety latch on the winch cable hook is fully seated when the load is attached.
- Never operate your winch with a damaged hook or latch. Always replace damaged parts before using the winch.

**Yes****No**

5. Never remove the hook strap from the hook.
6. Release the winch clutch and pull out the winch cable.
7. Pulling out as much cable as possible maximizes the winch's pulling capacity. Always be sure that at least five (5) full turns of winch cable are wrapped around the winch drum at all times. The friction provided by this wrapped cable allows the drum to pull on the winch cable and move the load.

WINCH GUIDE

8. Read and adhere to the following information for winch damping to ensure safe winch use.
 - a. In order to absorb energy that could be released by a winch cable failure, always place a “damper” on the winch cable. A damper can be heavy jacket, tarp, or other soft, dense object. A damper can absorb much of the energy released if a winch cable breaks when winching. Even a tree limb can help as a damper if no other items are available to you.
 - b. Lay the damper on top of the mid-point of the winch cable length that is spooled out.
 - c. On a long pull, it may be necessary to stop winching so that the damper can be repositioned to the new mid-point of the winch cable. Always release the tension on the winch cable before repositioning the damper.
 - d. Avoid being directly in line with the winch cable whenever possible. Also, never permit others to stand near or in line with the winch cable during winch operation.
9. Never hook the winch cable back onto itself. This will damage the winch cable and may result in winch cable failure.
10. Never use straps, chains or other rigging items that are damaged or worn.

11. The ONLY time a winch-equipped vehicle should be moving when using the winch is when that vehicle itself is stuck. The winch equipped vehicle should NEVER be in motion to “shock” load the winch cable in an attempt to move a second stuck vehicle. See the Shock Loading section on page 71. For your safety, always follow these guidelines when winching a vehicle free:
 - a. Release the winch clutch and spool out the necessary length of winch cable.
 - b. Align the winch cable as close as possible to the winching vehicle's centerline.
 - c. Attach the winch cable hook to the anchor point or the stuck vehicle's frame following instructions in this manual.
 - d. Re-engage the clutch on the winch.
 - e. Slowly winch in the slack in the winch cable.
 - f. Select the proper vehicle gear to propel the stuck vehicle in the direction of winching.
 - g. Shift to the lowest gear available on the stuck vehicle.
 - h. Slowly and carefully apply vehicle throttle and winch together to free the vehicle.
 - i. Stop winching as soon as the stuck vehicle is able to propel itself without the help of the winch.
 - j. Detach the winch cable hook.
 - k. Rewind the winch cable evenly back onto the winch drum following the instructions in this manual.
12. Never attempt to winch another stuck vehicle by attaching the winch cable to a suspension component, brush guard, bumper or cargo rack. Vehicle damage may result. Instead, attach the winch to a strong portion of the vehicle frame or hitch.
13. Extensive winching will run down the battery on the winching vehicle. Let the winching vehicle's engine run while operating the winch to prevent the battery from running low if winching for long periods.
14. The winch motor may become hot during winch use. If you winch for more than 45 seconds, or if the winch stalls during operation, stop winching and permit the winch to cool down for 10 minutes before using it again.

WINCH GUIDE

15. After winching is complete, especially if winching at an angle, it may be necessary to re-distribute the winch cable across the winch drum. You will need an assistant to perform this task.
 - a. Release the clutch on the winch.
 - b. Feed out the winch cable that is unevenly bunched up in one area.
 - c. Re-engage the winch clutch.
 - d. Have an assistant pull the winch cable tightly with about 100 lbs. (45 kg) of tension using the hook strap.
 - e. Slowly winch the cable in while your assistant moves the end of the winch cable back and forth horizontally to evenly distribute the winch cable on the drum.
 - f. Doing this reduces the chances of the winch cable “wedging” itself between lower layers of winch cable.

WINCH CABLE CARE

For your safety, always replace POLARIS winch parts (including the cable) with genuine POLARIS replacement parts available at your authorized POLARIS dealer.

WARNING

Use of worn or damaged cable could lead to sudden failure and SEVERE INJURY.

1. Always inspect your winch before each use. Inspect for worn or loose parts including mounting hardware. Never use the winch if any part needs repair or replacement.

- Always inspect your winch cable before each use. Inspect for worn or kinked winch cable.

A kinked winch cable made of wire rope is shown at right. Even after being “straightened out,” this cable has already been permanently and severely damaged. Promptly discontinue use of a winch cable in this condition.



A kinked winch cable made of wire rope that has been “straightened out” is shown at right. Even though it may look usable, the cable has been permanently and severely damaged. It can no longer transmit the load that it could prior to kinking. Promptly discontinue use of a winch cable in this condition.



A winch cable made of synthetic rope should be inspected for signs of fraying. Replace the cable if fraying is observed (shown at right). Promptly discontinue use of a winch cable in this condition.



Also replace the winch cable if there are fused or melted fibers. Such an area of the synthetic rope will be stiff and appear smooth or glazed. Promptly discontinue use of a winch cable in this condition.

SHOCK LOADING

WARNING

Your winch cable is very strong but it is NOT designed for dynamic, or “shock” loading. Shock loading may tension a winch cable beyond its strength and cause the cable to break. The end of a broken winch cable under such high loading can cause SEVERE INJURY or DEATH to you and other bystanders.

Winch cables are designed to NOT absorb energy. This is true of both wire-rope and synthetic-rope winch cables.

- Never attempt to “jerk” a load with the winch. For example, never take up slack in the winch cable by moving the winching vehicle in an attempt to move an object. This is a dangerous practice. It generates high winch cable loads that may exceed the strength of the cable. Even a slowly moving vehicle can create large shock loads in a winch cable.

WARNING

SEVERE INJURY or DEATH can result from a broken winch cable.

WINCH GUIDE

2. Never quickly turn the winch ON and OFF repeatedly (“jogging”). This puts extra load on the winch, winch cable, and generates excessive heat from the motor. This is a form of shock loading.
3. Never tow a vehicle or other object with your winch. Towing an object with a winch produces shock loading of the cable even when towing at slow speeds. Towing from a winch also positions the towing force high on the vehicle. This can cause instability of the vehicle and possibly lead to an accident.
4. Never use recovery straps with your winch. Recovery straps are designed to stretch and can store energy. This stored energy in the recovery strap is released if a winch cable fails making the event even more hazardous. Similarly, never use elastic “bungee” cords for winching.
5. Never use the winch to tie down a vehicle to a trailer or other transportation vehicle. This type of use also causes shock loading that can cause damage to the winch, winch cable, or vehicles used.

Your winch cable is designed and tested to withstand the loads produced by the winch motor when operated from a stationary vehicle. Always remember that the winch and winch cable are NOT designed for shock loading.

WINCH MAINTENANCE AND SERVICE SAFETY

WARNING

Improper or lack of winch maintenance and service could lead to SEVERE INJURY or DEATH. Always follow all winch instructions and warnings in this manual.

1. Always inspect your winch before each use. Inspect for worn or kinked winch cable. Also inspect for worn or loose parts including mounting hardware.
2. Permit your winch motor to cool down prior to servicing your winch.
3. Never work on your winch without first disconnecting the battery connections to prevent accidental activation of the winch.
4. For your safety, always replace POLARIS winch parts (including the cable) with genuine POLARIS replacement parts available at your authorized POLARIS dealer.
5. Some winch models use wire rope as the winch cable. Other winches use a specially designed synthetic rope as the winch cable.
6. Never replace a synthetic-rope winch cable with a consumer-grade polymer rope such as can be purchased in a hardware store. Although they may look similar, they are NOT alike. A polymer rope not designed for winch use will stretch and store excessive energy when winching.

WARNING

Failure of a stretched rope under winching conditions will release all of the stored energy. This will increase the chances of SEVERE INJURY or DEATH.

MAINTENANCE

MAINTENANCE OVERVIEW

Any qualified repair shop or person may maintain, replace or repair the emission control devices or systems on your vehicle. An authorized POLARIS dealer can perform any service that may be necessary for your vehicle. POLARIS also recommends POLARIS parts for emissions-related service, however equivalent parts can be used.

It is a potential violation of the Clean Air Act if a part supplied by an aftermarket parts manufacturer reduces the effectiveness of the vehicle's emission controls. Tampering with emission controls is prohibited by federal law.

Owners are responsible for performing the scheduled maintenance identified in this owner's manual.

Careful periodic maintenance will help keep your vehicle in the safest, most reliable condition. Inspection, adjustment and lubrication of important components are explained in the periodic maintenance chart.

Inspect, clean, lubricate, adjust and replace parts as necessary. When inspection reveals the need for replacement parts, genuine POLARIS parts are available from your POLARIS dealer. Equivalent parts may be used for emissions-related service.

Service and adjustments are important for proper vehicle operation. If you're not familiar with safe service and adjustment procedures, a qualified dealer can perform these operations.

Vehicles subjected to heavy or severe use patterns must be inspected and serviced more frequently.

SEVERE USE DEFINITION

- Frequent immersion in mud, water or sand
- Frequent or prolonged operation in dusty environments
- Short trip cold weather operation
- Racing or race-style high RPM use
- Prolonged low speed, heavy load operation
- Extended idle

Pay special attention to the oil level. A rise in oil level during cold weather can indicate contaminants collecting in the oil sump or crankcase. Change oil immediately if the oil level begins to rise. Monitor the oil level, and if it continues to rise, discontinue use and determine the cause. Your dealer can assist.

MAINTENANCE CHART KEY

SYMBOL	DESCRIPTION
XU	Perform these procedures more often for vehicles subjected to severe use.
D	Have an authorized Polaris dealer or other qualified person perform these services.

MAINTENANCE

WARNING

Improperly performing the procedures marked with a **D** could result in component failure and lead to serious injury or death. Have an authorized POLARIS dealer or other qualified person perform these services.

PERIODIC MAINTENANCE CHART

Perform all services at whichever maintenance interval is reached first. Record maintenance and service in the Maintenance Log.

ITEM		MAINTENANCE INTERVAL (WHICHEVER COMES FIRST)		REMARKS
		HOURS	CALENDAR	
D	Steering	-	Pre-Ride	Inspect operation; Make adjustments as needed.
XU	Front Suspension	-	Pre-Ride	
XU	Rear Suspension	-	Pre-Ride	
	Tires	-	Pre-Ride	
XU	Brake Fluid Level	-	Pre-Ride	
XU	Brake Pedal Travel	-	Pre-Ride	
	Brake Systems	-	Pre-Ride	
	Wheels / Fasteners	-	Pre-Ride	
	Frame Fasteners	-	Pre-Ride	
	Head Lamp / Tail Lamp	-	Daily	
XU D	Brake Pad Wear	10 H	Monthly	Inspect periodically
XU D	Parking Brake Cable Adjustment	25 H	-	Inspect; adjust after first 25 hours
	Battery Terminals (Clean)	25 H	Monthly	Clean terminals and cable ends
	Battery Terminals (Torque)	25 H	Monthly	Re-torque terminal nuts
	Battery Fluid Level	25 H	Monthly	Inspect and add distilled water as needed
XU	Front Gearcase Lubricant	25 H	Monthly	Inspect level; change yearly
XU	Transaxle (Rear Gearcase) Lubricant	25 H	Monthly	Inspect level; change yearly
XU	General Lubrication	50 H	3 Months	Lubricate fittings, pivots, cable ends
D	Steering	50 H	6 Months	Inspect; Lubricate

ITEM		MAINTENANCE INTERVAL (WHICHEVER COMES FIRST)		REMARKS
		HOURS	CALENDAR	
XU	Front Suspension	50 H	6 Months	Check fastener torque; Check that cotter pins are in place on castle nuts. Check and lubricate tie rod ends.
XU	Rear Suspension	50 H	6 Months	Check fastener torque; Check that cotter pins are in place on castle nuts. Lubricate stabilizer bar pivots and A-arm joints.
XU	Wiring	100 H	12 Months	Inspect for wear, routing, security; apply dielectric grease to non-sealed connectors subjected to water, mud, etc.
D	Front Wheel Bearings	100 H	12 Months	Inspect; replace as needed
D	Brake Fluid	200 H	24 Months	Change every two years (DOT 4)
	Suspension Bushings	250 H	24 Months	Inspect; replace as needed
D	Toe Adjustment	-		Inspect periodically; adjust when parts are replaced
	Headlight Aim	-		Adjust as needed

XU Perform these procedures more often for vehicles subjected to severe use.

D Have an authorized Polaris dealer or other qualified person perform these services.

LUBRICATION RECOMMENDATIONS

Check and lubricate all components at the intervals outlined in the Periodic Maintenance Chart beginning on page 76, or more often under severe use, such as wet or dusty conditions. Items not listed in the chart should be lubricated at the general lubrication interval.

ITEM	LUBE	METHOD
Brake Fluid	DOT 4 Brake Fluid	Maintain level between fill lines. See page 81.
Main Gearcase Oil (Transaxle)	ATV Angle Drive Fluid	See page 78.
Front Gearcase Oil	Demand Drive Fluid	See page 80.

MAINTENANCE

GEARCASES

GEARCASE SPECIFICATION CHART

GEARCASE	LUBRICANT	CAPACITY	FILL PLUG TORQUE	DRAIN PLUG TORQUE
Main Gearcase (Transaxle)	ATV Angle Drive Fluid	20.3 oz. (600 ml)	14 ft lbs (19.4 Nm)	14 ft lbs (19.4 Nm)
Front Gearcase	Demand Drive Fluid	5.1 oz. (150 ml)	8–10 ft lbs (11–13.6 Nm)	11 ft lbs (15 Nm)

MAIN GEARCASE (TRANSAXLE)

Always check and change the main gearcase oil at the intervals outlined in the Periodic Maintenance Chart. Maintain the oil level even with the bottom thread of the fill plug hole ①.

Refer to the Gearcase Specifications Chart for recommended lubricants, capacities and torque specifications.



OIL CHECK

The fill plug is located at the right rear of the vehicle.

To check the oil, do the following:

1. Position the vehicle on a level surface.
2. Remove the fill plug ①.
3. Check the oil level.
4. Add the recommended oil as needed.

5. Reinstall the fill plug. Torque to specification.

OIL CHANGE

The drain plug ② is located on the lower right side of the main gearcase, near the fill plug ①. Refer to the Gearcase Specifications Chart for recommended lubricants, capacities and torque specifications.

To change the oil, do the following:

1. Remove the fill plug.
2. Place a drain pan under the drain plug. Remove the drain plug. Allow the oil to drain completely.
3. Wipe the magnetic end of the drain plug clean to remove accumulated metallic filings.
4. Reinstall the drain plug. Torque to specification.
5. Add the recommended oil as needed. Do not overfill.
6. Reinstall the fill plug. Torque to specification.
7. Check for leaks. Dispose of used oil properly.

MAINTENANCE

FRONT GEARCASE

Always check and change the front gearcase oil at the intervals outlined in the Periodic Maintenance Chart. Maintain the oil level even with the bottom thread of the fill plug hole ①.

Refer to the Gearcase Specifications Chart for recommended lubricants, capacities and torque specifications.

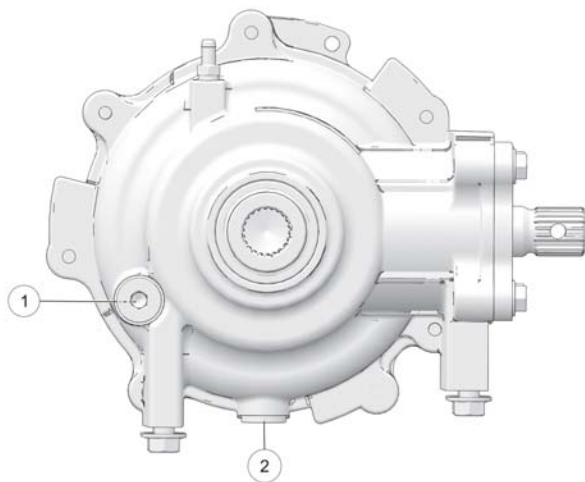

OIL CHECK

The front gearcase fill plug is located on the left side of the front gearcase.

To check the oil, do the following:

1. Position the vehicle on a level surface.
2. Remove the fill plug ①.
3. Check the oil level.
4. Add the recommended oil as needed.
5. Reinstall the fill plug. Torque to specification.

OIL CHANGE

The drain plug ② is located on the lower right side of the main gearcase, near the fill plug ①. Refer to the Gearcase Specifications Chart for recommended lubricants, capacities and torque specifications.

To change the oil, do the following:

1. Support the vehicle securely with a jackstand.
2. Remove the front tire on the driver's side.

3. Place a drain pan under the drain plug. Remove the drain plug. Allow the oil to drain completely.
4. Wipe the magnetic end of the drain plug clean to remove accumulated metallic filings.
5. Reinstall the drain plug. Torque to specification.
6. Add the recommended oil as needed. Do not overfill.
7. Reinstall the fill plug. Torque to specification.
8. Check for leaks. Dispose of used oil properly.

BRAKES

The front and rear brakes are hydraulic disc type brakes activated by the brake pedal.

Always check brake pedal travel and the brake fluid reservoir level before each use of the vehicle. When applied, the brake pedal should feel firm. Any sponginess would indicate a possible fluid leak or low brake fluid level, which must be corrected before riding. Proceed to the next page for brake fluid information.

If you discover any irregularities in brake system operation, including excessive pedal travel, contact your POLARIS dealer for proper diagnosis and repairs.

WARNING

Operating the vehicle with a spongy brake pedal can result in loss of braking, which could cause an accident resulting in severe injury or death. Never operate the vehicle with a spongy-feeling brake pedal.

MAINTENANCE

BRAKE FLUID

Inspect the brake system routinely. Inspect the level of the brake fluid before each operation.

⚠ WARNING

After opening a bottle of brake fluid, always discard any unused portion. Never store or use a partial bottle. Brake fluid is hygroscopic, meaning it rapidly absorbs moisture from the air. The moisture causes the boiling temperature of the brake fluid to drop, which can lead to early brake fade and the possibility of accident or severe injury.

Change the brake fluid every two years and any time the fluid becomes contaminated, the fluid level is below the minimum, or if the type and brand of the fluid in the reservoir are unknown.

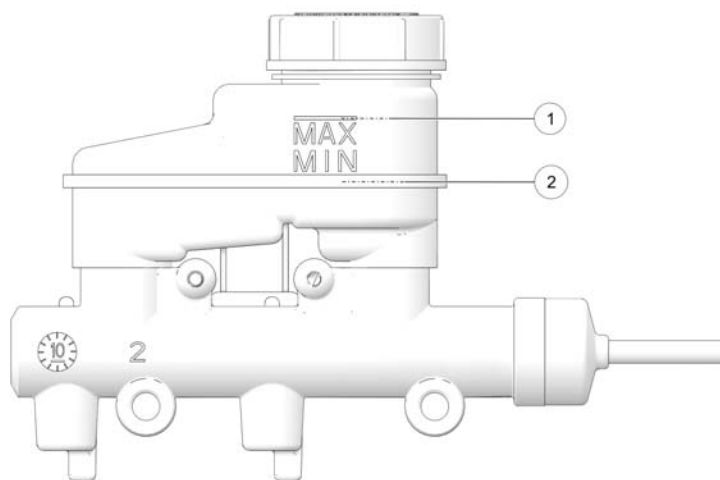

To check the brake fluid level, do the following:

1. Position the vehicle on a level surface.
2. View the brake fluid level at the reservoir in the driver's side wheel well. The level should be between the upper (MAX) ① and lower (MIN) ② level lines.
3. If the fluid level is lower than the upper level line, add brake fluid to the upper (MAX) line ①.
4. Apply the brake forcefully for a few seconds and check for fluid leakage around the fittings.

BRAKE INSPECTION

WARNING

Do not apply WD-40 or any petroleum product to brake discs. These types of products are flammable and may also reduce the friction between the brake pad and caliper.

To inspect the brakes, do the following:

1. Check the brake system for fluid leaks.
2. Check the brake pedal for excessive travel or a spongy feel.
3. Check the friction pads for wear, damage and looseness.
4. Check brake discs for signs of cracks, excessive corrosion, warping or other damage. Clean any grease using an approved brake cleaner or alcohol.
5. Inspect the brake disc spline and pad wear surface for excessive wear. Change pads ① when worn to .030" (0.762 mm).

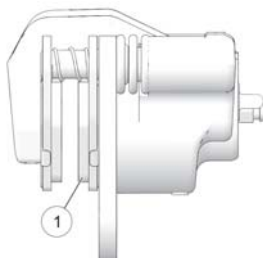

STEERING WHEEL INSPECTION

Check the steering wheel for specified freeplay and smooth operation at the intervals outlined in the Periodic Maintenance Chart section.

1. Position the vehicle on level ground.
2. Lightly turn the steering wheel left and right.
3. There should be 0.8"-1.0" (20-25 mm) of freeplay.
4. If there is excessive freeplay or strange noises, or the steering feels rough or "catchy," have the steering system inspected by an authorized dealer.

SUSPENSION ADJUSTMENT

Adjust the front and rear shock absorber springs by rotating the adjustment cam either clockwise or counter-clockwise to increase or decrease spring tension.

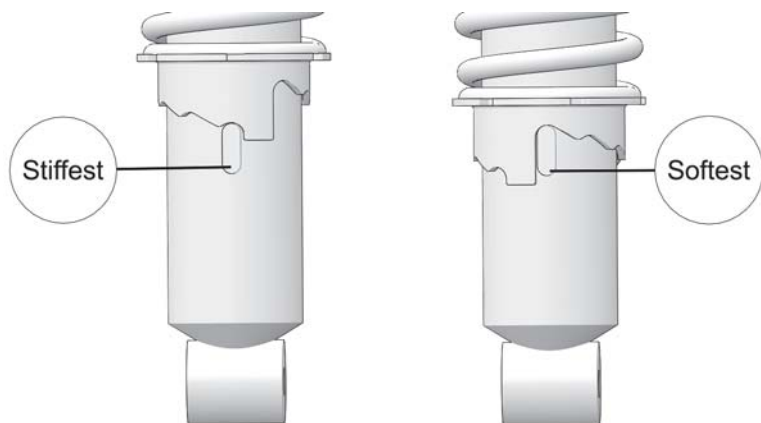

Always heed the following rules if you make adjustments to this suspension.

- Always return the suspension to the lowest (softest) setting after the load is removed from the vehicle. The increased suspension height will negatively impact vehicle stability when operating without a load.
- Always apply the same adjustment setting to both rear wheels.
- Never operate the vehicle on the highest (stiffest) or second highest preload settings without a total combined payload in the vehicle of 450 lbs. (204 kg) or more. Payload includes the driver, approved accessories and cargo. Never exceed the stated load capacity for this vehicle.

TIRES

⚠ WARNING

Operating your vehicle with worn tires will increase the possibility of skidding, loss of control and an accident, which could result in serious injury or death.

Always replace tires when the tread depth measures 1/8" (3 mm) or less.

Improper tire inflation or the use of non-standard size or type of tires may adversely affect vehicle handling, which could result in vehicle damage or personal injury. Always maintain proper tire pressure. Always use POLARIS approved size and type of tires for this vehicle when replacing tires.

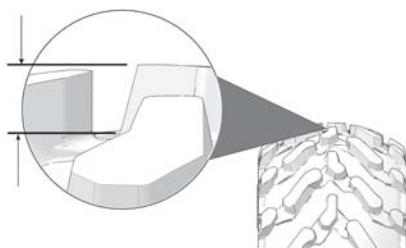

TIRE TREAD DEPTH

Always replace tires when tread depth is worn to 1/8" (3 mm) or less.



AXLE AND WHEEL NUT TORQUE SPECIFICATIONS

Inspect the following items occasionally for tightness, and if they've been loosened for maintenance service. Do not lubricate the stud or the lug nut.

<p>Lug Nut (Aluminum Wheels)</p> 	<p>Front and Rear</p>	<p>30 ft. lbs. (41 Nm) PLUS 1/4 TURN or 90 degrees</p>
<p>2-Piece Flange Nut (Steel Wheels)</p> 	<p>Front and Rear</p>	<p>35 ft. lbs. (47 Nm)</p>
<p>Spindle Nut</p>	<p>Front</p>	<p>70 ft. lbs. (95 Nm)</p>
<p>Hub Retaining Nut</p>	<p>Center and Rear</p>	<p>110 ft. lbs. (150 Nm)</p>

MAINTENANCE

WHEEL REMOVAL

1. Position the vehicle on a level surface.
2. Place the transmission in PARK. Stop the engine.
3. Loosen the wheel nuts slightly.
4. Elevate the side of the vehicle by placing a suitable stand under the frame.
5. Remove the wheel nuts and washers. Remove the wheel.

WHEEL INSTALLATION

1. Place the transmission in PARK.
2. Place the wheel on the hub with the valve stem toward the outside and rotation arrows on the tire pointing toward forward rotation.

WARNING

Improperly installed wheels can adversely affect tire wear and vehicle handling, which can result in serious injury or death. Always ensure that all nuts are torqued to specification. Do not service axle nuts that have a cotter pin installed. Your dealer can assist.

3. Attach the wheel nuts and washers and finger-tighten.
4. Carefully lower the vehicle to the ground.
5. Torque the wheel nuts to specification.

LIGHTS

Poor lighting can result in reduced visibility when driving. Headlight and taillight lenses become dirty during normal operation. Clean lights frequently and replace burned out lamps promptly. Do not operate this vehicle at night or in low light conditions until the headlight is replaced. Always make sure lights are adjusted properly for best visibility.

When servicing a halogen lamp, don't touch the lamp with bare fingers. Oil from your skin leaves a residue, causing a hot spot that will shorten the life of the lamp.

HEADLIGHT LAMP REPLACEMENT

CAUTION

Hot components can cause burns to skin. Allow lamps to cool before servicing.

To replace the headlight lamp, do the following:

1. Access the headlamp wiring harnesses through the front wheel wells.
2. Unplug the headlamp from the wiring harness. Be sure to pull on the connector, not on the wiring.
3. Turn the lamp counter-clockwise to remove it.
4. Install the new lamp.

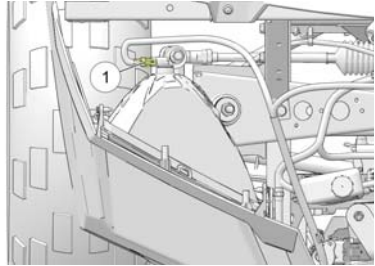

TIP

Make sure the tab on the lamp locates properly in the housing.

5. Reinstall the harness assembly into the headlight assembly.

MAINTENANCE

HEADLIGHT BEAM ADJUSTMENT

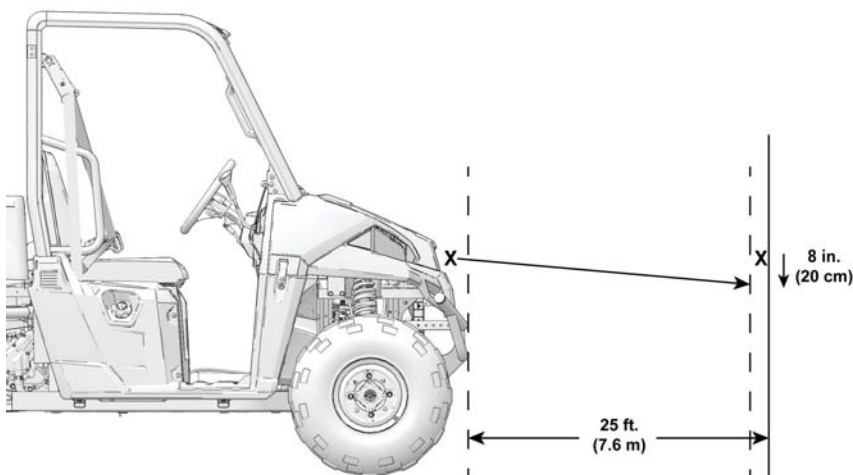

To adjust the headlight beam, do the following:

1. Place the vehicle on a level surface with the headlight approximately 25 ft. (7.6 m) from a wall.
2. Measure the distance from the floor to the center of the headlight and make a mark on the wall at the same height.
3. Apply the brakes. Start the engine. Turn on the headlights.
4. Observe the headlight aim. The most intense part of the headlight beam should be aimed 8" (20 cm) below the mark placed on the wall. Include the weight of a rider on the seat while performing this step.
5. If a headlight needs adjustment, locate the adjustment screw at the back of the headlight.
6. Loosen the screw, adjust the headlight, and tighten the screw.
7. Repeat steps 4-6 until the lamp is properly adjusted.

BRAKE LIGHTS

When the brake pedal is depressed, the brake light comes on. Check the brake light before each ride.

To check the brake lights, do the following:

1. Turn the key to the ON position.
2. Depress the brake pedal. The brake light should come on after about 10mm (0.4 in.) of pedal travel. If the light doesn't come on, check the bulb.

INDICATOR LAMP REPLACEMENT

To replace the indicator lamp, do the following:

1. Lift the hood.
2. Reach in behind the console panel and lift the release to unplug the light from the harness.
3. Using a flathead screwdriver, press on the tab on the top of the light to remove the indicator light assembly from the console panel.
4. Locate the expired lamp. Using a screwdriver, rotate the lamp 1/4 turn counter-clockwise.
5. Grip the lamp with a needle-nose pliers and remove it from the assembly.
6. Install the new lamp. Using a screwdriver, rotate the lamp 1/4 turn clockwise to seat it.
7. Snap the assembly back into the console panel. Reconnect the harness.
8. Close the hood.

BATTERY

WARNING

Battery electrolyte is poisonous. It contains sulfuric acid. Serious burns can result from contact with skin, eyes or clothing.

Antidote:

External: Flush with water.

Internal: Drink large quantities of water or milk. Follow with milk of magnesia, beaten egg, or vegetable oil. Call physician immediately.

Eyes: Flush with water for 15 minutes and get prompt medical attention.

Batteries produce explosive gases. Keep sparks, flame, cigarettes, etc. away. Ventilate when charging or using in an enclosed space. Always shield eyes when working near batteries. KEEP OUT OF REACH OF CHILDREN.

Your vehicle may have either a sealed battery, which requires little maintenance, or a conventional battery. A sealed battery can be identified by its flat covers on the top of the battery. A conventional battery has six filler caps on the top of the battery.

Always keep battery terminals and connections free of corrosion. If cleaning is necessary, remove the corrosion with a stiff wire brush. Wash with a solution of one tablespoon baking soda and one cup water. Rinse well with tap water and dry off with clean shop towels. Coat the terminals with dielectric grease or petroleum jelly. Be careful not to allow cleaning solution or tap water into a conventional battery.

MAINTENANCE

WARNING

Improperly connecting or disconnecting battery cables can result in an explosion and cause serious injury or death. When removing the battery, always disconnect the negative (black) cable first. When reinstalling the battery, always connect the negative (black) cable last.

BATTERY CHARGING

When not in use, park the vehicle and connect the battery charger. The vehicle's charging cord is located inside the right front bumper.

WARNING

Failure to provide adequate ventilation while charging batteries can result in an explosion. Hydrogen gas is emitted during charging and will rise and accumulate at the ceiling. Always ensure a minimum of five (5) air changes per hour in the charging area. Never charge the batteries in an area subject to a flame or spark, including areas containing gas or propane water heaters and furnaces. Do not smoke in the charging area.

Always follow these precautions when charging the batteries:

1. Position the vehicle on a level surface.
2. Make sure the charging area is well ventilated.
3. Make sure the key is off.
4. Open the hood and any door enclosures or zippers.
5. Always use a extension cord with a minimum rating of 20 amps.
6. Inspect the charging cord and extension cord for cracks, loose connections and frayed wiring. Replace any damaged components promptly.
7. Always connect the vehicle charger to the extension cord first, then plug the cord into a wall receptacle.
8. Make sure the charger uses a dedicated circuit to prevent overloading. If charging multiple vehicles, each vehicle should use a dedicated circuit.

TIP

After the batteries have fully recharged, the battery charger will automatically cycle in and out of the trickle charge mode to maintain the charge.

9. When disconnecting the charger, always disconnect the extension cord from the wall receptacle first, then disconnect the cord from the vehicle's charging cord.

BATTERY ACCESS

To access the batteries, do the following:

1. Remove the seat.
2. Remove the storage tray (if equipped)

NOTE

Before removing the seat to access the batteries, make sure any wire or metal items (including seat belt latches) remain clear of the battery compartment to avoid causing a short circuit to the electrical system.

BATTERY INSPECTIONS

Inspect battery terminal connections monthly. Clean batteries as recommended. Using an insulated wrench, torque bolts to 8 ft. lbs. (11 Nm).

BATTERY CLEANING

Always keep battery terminals and connections free of corrosion. To clean, remove corrosion with a stiff wire brush. Wash with a solution of one tablespoon baking soda and one cup water. Rinse well with tap water and dry off with clean shop towels. Coat battery terminals with dielectric grease or petroleum jelly.

NOTE

Do not allow cleaning solution or tap water to enter the batteries.

BATTERY REPLACEMENT

With proper care and maintenance as outlined in this owner's manual, battery life could be extended up to four years or longer, depending on the amount of use. When battery replacement is necessary, please see your authorized POLARIS dealer.

WARNING

Handling batteries and electrical components improperly can result in serious injury or death. Do not attempt to remove batteries or battery cables. Always see your dealer for battery-related service.

MAINTENANCE

BATTERY FLUID

A poorly maintained battery will deteriorate rapidly. Check the battery fluid level often. Add only distilled water. Tap water contains minerals that are harmful to a battery.

Unless the plates are exposed before charging, distilled water should be added to a battery after charging. If the plates ③ are exposed, add water to about 1/8 inch (3 mm) above the level, then charge. Check the fluid level again after charging. Maintain the fluid level 1/4 inch (6 mm) ① below the bottom of the fill well ② in the cell cover. Do not overfill.

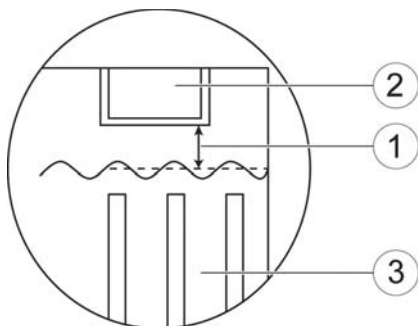

CLEANING AND STORAGE

WASHING THE VEHICLE

Keeping your POLARIS vehicle clean will not only improve its appearance but it can also extend the life of various components.

NOTE

High water pressure may damage components. POLARIS recommends washing the vehicle by hand or with a garden hose, using mild soap.

NOTE

Certain products, including insect repellents and chemicals, will damage plastic surfaces. Do not allow these types of products to contact the vehicle.

The best and safest way to clean your POLARIS vehicle is with a garden hose and a pail of mild soap and water.

1. Use a professional-type washing cloth, cleaning the upper body first and the lower parts last.
2. Rinse with clean water frequently.
3. Dry surfaces with a chamois to prevent water spots.

WASHING TIPS

- Avoid the use of harsh cleaners, which can scratch the finish.
- Do not use a power washer to clean the vehicle.
- Do not use medium to heavy duty compounds on the finish.
- Always use clean cloths and pads for cleaning and polishing. Old or reused cloths and pads may contain dirt particles that will scratch the finish.

- Grease all zerk fittings immediately after washing. Allow the engine to run for a while to evaporate any water that may have entered the engine or exhaust system.

If a high pressure water system is used for cleaning (not recommended), exercise extreme caution. The water may damage components and could remove paint and labels. Avoid directing the water stream at the following items:

- Wheel bearings
- Radiator
- Transmission seals
- Brakes
- Cab and body panels
- Labels and decals
- Electrical components and wiring
- Air intake components

If an informational or graphic label becomes illegible or comes off, contact your POLARIS dealer to purchase a replacement. Replacement safety labels are provided by POLARIS at no charge.

POLISHING THE VEHICLE

POLARIS recommends the use of common household aerosol furniture polish for polishing the finish on your POLARIS vehicle. Follow the instructions on the container.

POLISHING TIPS

- Avoid the use of automotive products, some of which can scratch the finish of your vehicle.
- Always use clean cloths and pads for cleaning and polishing. Old or reused cloths and pads may contain dirt particles that will scratch the finish.

CHROME WHEEL CARE (IF EQUIPPED)

Proper maintenance will protect chrome wheels from corrosion, preserve wheel life and ensure a “like new” appearance for many years. Chrome wheels exposed to road salt (or salt in the air in coastal areas) are more susceptible to corrosion if not properly cleaned. Clean chrome wheels more often if they’re exposed to salt or other corrosive elements.

1. Wash chrome wheels frequently. Use a mild detergent. Never use abrasive cleaners on plated or painted surfaces.
2. Rinse well with clear water. Soap, detergents, salt, dirt, mud and other elements can cause corrosion.
3. Polish the clean chrome wheels periodically. Use an automotive grade chrome polish.

MAINTENANCE

4. Routinely and liberally apply a weather resistant wax to each polished chrome wheel. Choose a product suitable for chrome finishes. Read and follow the product labels and instructions.

REMOVING CORROSION

If light rust is found on the chrome finish, use steel wool (#0000-OTT grade) to remove it. Gently rub the affected areas with the steel wool until the corrosion has been removed. Clean and polish the wheel as outlined above.

STORING THE VEHICLE

Any time the vehicle will be parked for more than a few hours, follow the recommended storage procedures:

1. Make any necessary repairs and clean the vehicle.
2. Clean the batteries.
3. Store the vehicle out of the sun in a cool, dry place.
4. Be sure the storage area is well ventilated.
5. Turn the key off.
6. *DO NOT* set the park brake.
7. Verify that tire pressure is at specification.
8. Block the wheels to prevent rolling.
9. Fully charge the batteries. Leave the charger connected to maintain a full charge during the storage period, or check battery voltage each month during storage and recharge as needed to maintain a full charge. If the charger remains connected, check it monthly to verify proper operation.

TIP

Do not use plastic or coated materials. They do not allow enough ventilation to prevent condensation, and may promote corrosion and oxidation.

WARNING

Do not cover the vehicle while the charger is connected. Dangerous levels of hydrogen gas could accumulate.

STORAGE TIPS

NOTICE

Starting the engine during the storage period will disturb the protective film created by fogging and damage could occur. Never start the engine during the storage period.

CLEAN THE EXTERIOR

Make any necessary repairs and clean the vehicle as recommended.

FLUID LEVELS

Inspect the fluid levels. Add or change fluids as recommended in the Periodic Maintenance Chart.

- Demand drive fluid (front gearcase)
- Rear gearcase fluid (if equipped)
- Transmission fluid
- Brake fluid (change every two years and any time the fluid looks dark or contaminated)
- Coolant (test strength/fill)

STORAGE AREA / COVERS

Be sure the storage area is well ventilated. Cover the vehicle with a genuine POLARIS cover. Do not use plastic or coated materials. They do not allow enough ventilation to prevent condensation, and may promote corrosion and oxidation.

REMOVAL FROM STORAGE

1. Inspect all battery connections.
2. Verify that batteries are fully charged.
3. Verify that tire pressure is at specification.
4. Perform the pre-ride inspection.
5. Inspect and verify the tightness of the bolts, nuts and other fasteners.
6. Lubricate at the intervals outlined in the Periodic Maintenance Chart.

MAINTENANCE

TRANSPORTING THE VEHICLE

Follow these procedures when transporting the vehicle.

1. Apply the brakes.
2. Place the transmission in PARK. Stop the engine.
3. Slowly release the brake pedal and make sure the transmission is in PARK before exiting the vehicle. Engage the park brake.
4. Remove the key to prevent loss during transporting.
5. Secure the fuel cap and seat. Ensure that the seat is attached correctly and is not loose.

WARNING

Cargo and other loose vehicle parts may fly off while transporting this vehicle. Secure or remove all cargo, and inspect the unit for loose parts prior to transport.

6. Always tie the frame of the vehicle to the transporting unit securely with suitable straps or rope. Do not attach tie straps to the front control arm bolt pockets.

SPECIFICATIONS

RANGER® EV SPECIFICATIONS

DIMENSIONS	
Dry Weight	1750 lbs. (793.8 kg)
Test GVW - Rollover Protection System (ROPS)	2750 lbs. (1247 kg) per OSHA 29 CFR 1928.53
Ground Clearance	10 in. (25.4 cm)
Length	108 in. (274.3 cm)
Width	56.5 in. (143.5 cm)
Height	73 in. (185.4 cm)
Wheelbase	72 in. (183 cm)
Turning Radius	150 in. (381 cm)

LOAD CAPACITY	
Box Dimensions (Inside)	32 x 42 x 11.5 in. (81 x 107 x 29 cm)
Box Capacity	500 lbs. (227 kg)
Payload Capacity	1000 lbs. (455 kg)
Hitch Towing Capacity	1250 lbs. (567 kg)
Cargo System	Lock & Ride®
Seating	2
Skid Plate	Plastic

PERFORMANCE	
Motor configuration	Single, 48-volt, high efficiency, AC induction motor
Motor peak	30 HP
Controller	650 - Amp Sevcon Gen IV controller with multi-mode driving and regenerative braking

SPECIFICATIONS

PERFORMANCE	
Battery pack	11.7 kw battery pack at 48V DC with 8 12-volt, US12VXC batteries in series-parallel configuration
Maximum speed	25 MPH (40.2 km/h)
Range (in Max Range mode on flat ground)	50 miles (80.5 km) (may vary with driving conditions)
Throttle	Redundant, non-contact, inductive-sensing pedal
On-board charger	Delta Q 120-volt AC input; 48-volt DC output
Charge time	8 hours (dependent on depth of discharge)

DRIVETRAIN	
Main gearcase (transaxle)	Direct drive motor-to-transaxle with low-noise gears
Drive	On demand AWD, 2WD, turf mode

BRAKE SYSTEM	
Brakes	4-Wheel hydraulic disc w/dual bore front calipers
Park Brake	Dash-mounted lever-activated mechanical park brake

SUSPENSION	
Front suspension	McPherson Strut w/9 in. (22.7 cm) of travel
Rear suspension	Dual A-Arm w/9 in. (22.9 cm) travel
Tires	25x9-12 Carlisle All Trail II
Tire pressure	20 psi (137.9 kPa) Features

SPECIFICATIONS

FEATURES	
Cup holders	Dual cup holders
Indicator panel	Indicates directional selection, park brake, and motor or controller malfunction
Charge indicator	Digital, indicates battery discharge
Hour meter	Digital, indicates cumulative hours of vehicle movement
Auxiliary power	12-volt accessory outlet
Rider restraints	Automotive-style 3-point seat belts
Multi-mode switch	L/M/H (Low/Max Range/High)
Headlights/taillights/brake lights	Dual 50-watt
Storage	Glove box

POLARIS PRODUCTS

LUBRICANTS / SERVICE PRODUCTS

PRODUCT	SIZE (QUANTITY)	PART NUMBER
Fogging Oil	12 oz aerosol (12)	2870791
	1 qt (12)	2871517
PS-4	1 qt (12)	2876244
	2 qt (8)	2877490
	1 gal (4)	2876245
PS-4 Extreme Duty	1 qt (12)	2878920
	2 qt (8)	2878922
	1 gal (4)	2878919
AGL	1 qt (12)	2878068
	1 gal (4)	2878069
Pump for Gallon Jug	3.8 l	2870465
Demand Drive	1 qt (12)	2877922
	2.5 gal (2)	2877923
Antifreeze / Coolant	1 qt (12)	2880514
	1 gal (6)	2880513
Grease Gun Kit, Premium All Season	—	2871312
All Season Grease	Four 3 oz packs (6)	2871322
	14 oz cartridge	2871423
Premium Starter Grease	—	2871460
U-Joint Grease	3 oz tube (24)	2871515
	14 oz cartridge	2871551
Dielectric Grease (Nyogel™)	—	2871329
Carbon Clean	12 oz bottle (12)	2871326
Fuel Stabilizer	16 oz (12)	2870652
	2.5 gal (2)	2872280
DOT 4 Brake Fluid	—	2872189
Loctite™ 565 Thread Sealant	—	2871956
POLARIS Battery Tender™ Charger	—	2859044

TROUBLESHOOTING

VEHICLE WILL NOT OPERATE

POSSIBLE CAUSE	SOLUTION
Low battery voltage	Recharge the battery overnight
Loose battery connections	Check all connections and tighten
Loose contactor connections	Check all connections and tighten
Loose electronic control box connections	Inspect, clean, reinstall connectors
Required torque exceeds motor capability	Apply the brakes and select low range

MALFUNCTION INDICATOR TROUBLESHOOTING

The malfunction codes will blink on the controller. The code definitions provided here are for informational purposes only.

TIP

If the indicator illuminates due to a minor issue such as a low voltage condition or a sequence fault (reversing direction without releasing the accelerator), select neutral and turn the key off and on to clear the error. If the error does not clear, please see your POLARIS dealer for diagnosis and repair.

NUMBER OF BLINKS	CODE DEFINITION
1	Data or configuration error
2	Sequence fault
3	Power fault
4	Contactor issue
6	Throttle input error
7	Voltage protection
8	Controller or motor out of temperature range
13	Software fault

CHARGE STATUS INDICATOR TROUBLESHOOTING GUIDE

The code definitions provided are for informational purposes only. Please see your POLARIS dealer for diagnosis and repair.

Number of Blinks	Code Definition	Solution
1	Battery high voltage	Check battery size and condition; reset charger (interrupt AC power for 15 seconds)
2	Battery low voltage	
3	Charge time-out, battery pack not reaching required voltage, charger output reduced due to high temperatures	Check connections; operate charger at lower ambient temperature
4	Battery could not be trickle-charged to minimum voltage	Check battery for shorted or damaged cells
5	Charger shut down due to overheating	Ensure sufficient cooling air flow (open the hood) and reset the charger (interrupt AC power for 15 seconds)
6	Charger internal fault	Reset charger (interrupt AC power for 15 seconds); return to qualified service provider if fault persists

WARRANTY

LIMITED WARRANTY

POLARIS Industries Inc., 2100 Highway 55, Medina, MN 55340 (POLARIS) gives a ONE YEAR LIMITED WARRANTY on all components of your POLARIS vehicle against defects in material or workmanship. POLARIS further warrants that the spark arrester in this product will meet the efficiency requirements of USFS standard 5100-1C for at least 1000 hours when subjected to normal use and when maintenance and installation are in accordance with POLARIS recommendations.

This warranty covers parts and labor charges for repair or replacement of defective parts and begins on the date of purchase by the original retail purchaser. This warranty is transferable to another owner during the warranty period through a POLARIS dealer, but any such transfer will not extend the original term of the warranty. The duration of this warranty may vary by international region based upon local laws and regulations.

REGISTRATION

At the time of sale, the Warranty Registration Form must be completed by your dealer and submitted to POLARIS within ten days of purchase. Upon receipt of this registration, POLARIS will record the registration for warranty. No verification of registration will be sent to the purchaser as the copy of the Warranty Registration Form will be your proof of warranty coverage. If you have not signed the original registration and received the customer copy, please contact your dealer immediately. **NO WARRANTY COVERAGE WILL BE ALLOWED UNLESS YOUR VEHICLE IS REGISTERED WITH POLARIS.** Initial dealer preparation and set-up of your vehicle is very important in ensuring trouble-free operation. Purchasing a machine in the crate or without proper dealer set-up will void your warranty coverage.

WARRANTY COVERAGE AND EXCLUSIONS

LIMITATIONS OF WARRANTIES AND REMEDIES

This POLARIS limited warranty excludes any failures that are not caused by a defect in material or workmanship. THIS WARRANTY DOES NOT COVER CLAIMS OF DEFECTIVE DESIGN. This warranty also does not cover acts of God, accidental damage, normal wear and tear, abuse or improper handling. This warranty also does not cover any vehicle, component, or part that has been altered structurally, modified, neglected, improperly maintained or used for racing, competition or purposes other than for which it was designed.

This warranty excludes damages or failures resulting from improper lubrication; improper engine timing; improper fuel; surface imperfections caused by external stress, heat, cold or contamination; operator error or abuse; improper component alignment, tension, adjustment or altitude compensation; snow, water, dirt or other foreign substance ingestion/contamination; improper maintenance; modified components; use of aftermarket or unapproved components, accessories, or attachments; unauthorized repairs; or repairs made after the warranty period expires or by an unauthorized repair center.

This warranty excludes damages or failures caused by abuse, accident, fire, or any other cause other than a defect in materials or workmanship and provides no coverage for consumable components, general wear items, or any parts exposed to friction surfaces, stresses, environmental conditions and/or contamination for which they were not designed or not intended, including but not limited to the following items:

- Wheels and tires
- Suspension components
- Brake components
- Seat components
- Clutches and components
- Steering components
- Batteries
- Light bulbs/Sealed beam lamps
- Filters
- Lubricants
- Bushings
- Finished and unfinished surfaces
- Carburetor/Throttle body components
- Engine components
- Drive belts
- Hydraulic components and fluids
- Circuit breakers/Fuses
- Electronic components
- Spark plugs
- Sealants
- Coolants
- Bearings

LUBRICANTS AND FLUIDS

1. Mixing oil brands or using non-recommended oil may cause engine damage. We recommend the use of POLARIS engine oil.
2. Damage or failure resulting from the use of non-recommended lubricants or fluids is not covered by this warranty.

This warranty provides no coverage for personal loss or expense, including mileage, transportation costs, hotels, meals, shipping or handling fees, product pick-up or delivery, replacement rentals, loss of product use, loss of profits, or loss of vacation or personal time.

THE EXCLUSIVE REMEDY FOR BREACH OF THIS WARRANTY SHALL BE, AT POLARIS' OPTION, REPAIR OR REPLACEMENT OF ANY DEFECTIVE MATERIALS, COMPONENTS, OR PRODUCTS. THE REMEDIES SET FORTH IN THIS WARRANTY ARE THE ONLY REMEDIES AVAILABLE TO ANY PERSON FOR BREACH OF THIS WARRANTY. POLARIS SHALL HAVE NO LIABILITY TO ANY PERSON FOR INCIDENTAL, CONSEQUENTIAL OR SPECIAL DAMAGES OF ANY DESCRIPTION, WHETHER ARISING OUT OF EXPRESS OR IMPLIED WARRANTY OR ANY OTHER CONTRACT, NEGLIGENCE, OR OTHER TORT OR OTHERWISE. THIS EXCLUSION OF CONSEQUENTIAL, INCIDENTAL, AND SPECIAL DAMAGES IS INDEPENDENT FROM AND SHALL SURVIVE ANY FINDING THAT THE EXCLUSIVE REMEDY FAILED OF ITS ESSENTIAL PURPOSE.

THE IMPLIED WARRANTY OF FITNESS FOR A PARTICULAR PURPOSE IS EXCLUDED FROM THIS LIMITED WARRANTY. ALL OTHER IMPLIED WARRANTIES (INCLUDING BUT NOT LIMITED TO THE IMPLIED WARRANTY OF MERCHANTABILITY) ARE LIMITED IN DURATION TO THE ABOVE SIX MONTH WARRANTY PERIOD. POLARIS DISCLAIMS ALL EXPRESS WARRANTIES NOT STATED IN THIS WARRANTY. SOME STATES DO NOT PERMIT THE EXCLUSION OR LIMITATION OF INCIDENTAL OR CONSEQUENTIAL DAMAGES OR ALLOW LIMITATIONS ON THE DURATION OF IMPLIED WARRANTIES, SO THE ABOVE LIMITATIONS MAY NOT APPLY TO YOU IF INCONSISTENT WITH CONTROLLING STATE LAW.

WARRANTY

HOW TO OBTAIN WARRANTY SERVICE

If your vehicle requires warranty service, you must take it to a POLARIS Servicing Dealer. When requesting warranty service you must present your copy of the Warranty Registration Form to the dealer. (THE COST OF TRANSPORTATION TO AND FROM THE DEALER IS YOUR RESPONSIBILITY.) POLARIS suggests that you use your original selling dealer; however, you may use any POLARIS Servicing Dealer to perform warranty service.

IN THE COUNTRY WHERE YOUR PRODUCT WAS PURCHASED:

Warranty or Service Bulletin repairs must be done by an authorized POLARIS dealer. If you move or are traveling within the country where your product was purchased, Warranty and Service Bulletin repairs may be requested from any authorized POLARIS dealer that sells the same line as your product.

OUTSIDE THE COUNTRY WHERE YOUR PRODUCT WAS PURCHASED:

If you are traveling temporarily outside the country where your product was purchased, you should take your product to an authorized POLARIS dealer. You must show the dealer photo identification from the country of the selling dealer's authorized location as proof of residence. Upon residence verification, the servicing dealer will be authorized to perform the warranty repair.

IF YOU MOVE:

If you move to another country, be sure to contact POLARIS Customer Assistance and the customs department of the destination country before you move. Product importation rules vary considerably from country to country. You may be required to present documentation of your move to POLARIS in order to continue your warranty coverage. You may also be required to obtain documentation from POLARIS in order to register your product in your new country. You should warranty register your product at a local POLARIS dealer in your new country immediately after you move to continue your warranty coverage and to ensure that you receive information and notices regarding your vehicle.

IF YOU PURCHASE FROM A PRIVATE PARTY:

If you purchase a POLARIS product from a private party, to be kept and used outside of the country in which the product was originally purchased, all warranty coverage will be denied. You must nonetheless register your product under your name and address with a local POLARIS dealer in your country to ensure that you receive safety information and notices regarding your product.

EXPORTED PRODUCTS

EXCEPT WHERE SPECIFICALLY REQUIRED BY LAW, THERE IS NO WARRANTY OR SERVICE BULLETIN COVERAGE ON THIS PRODUCT IF IT IS SOLD OUTSIDE THE COUNTRY OF THE SELLING DEALER'S AUTHORIZED LOCATION. This policy does not apply to products that have received authorization for export from POLARIS. Dealers may not give authorization for export. You should consult an authorized dealer to determine this product's warranty or service coverage if you have any questions. This policy does not apply to products registered to government officials or military personnel on assignment outside the country of the selling dealer's authorized location. This policy does not apply to Safety Bulletins.

NOTICE

If your product is registered outside of the country where it was purchased and you have not followed the procedure set above, your product will no longer be eligible for warranty or service bulletin coverage of any kind, other than safety bulletins. Products registered to government officials or military personnel on assignment outside of the country where the product was purchased will continue to be covered by the Limited Warranty.

Please work with your dealer to resolve any warranty issues. Should your dealer require any additional assistance, they will contact the appropriate person at POLARIS.

This warranty gives you specific legal rights, and you may also have other rights which vary from state to state or in different countries. If any of the above terms are void because of federal, state, local law, all other warranty terms will remain in effect.

For questions call POLARIS Customer Assistance:

United States & Canada: 1-800-POLARIS (1-800-765-2747)

French: 1-800-268-6334

WARRANTY

U.S.A. EPA EMISSIONS LIMITED WARRANTY

This emissions limited warranty is in addition to the POLARIS standard limited warranty for your vehicle. POLARIS Industries Inc. warrants that at the time it is first purchased, this emissions-certified vehicle is designed, built and equipped so it conforms with applicable U.S. Environmental Protection Agency emission regulations. POLARIS warrants that the vehicle is free from defects in materials and workmanship that would cause it to fail to meet these regulations.

The warranty period for off road vehicles 100cc or greater emissions-certified vehicles starts on the date of purchase by original retail purchaser and continues for a period of 500 hours of engine operation, 5000 kilometers (3100 miles) of vehicle travel, or 30 calendar months from the date of purchase, whichever comes first. The warranty period for ATVs less than 100cc emissions-certified vehicles starts on the date of purchase by original retail purchaser and continues for a period of 250 hours of engine operation, 2500 kilometers (1550 miles) of vehicle travel, or 30 calendar months from the date of purchase, whichever comes first. This EPA emissions warranty period is extended for at least as long as the standard factory warranty that Polaris provides on the vehicle as a whole. The EPA emissions warranty period does not further extend if you purchase additional warranty coverage in the form of a service contract or other paid warranty extension, but emission-related parts may be covered subject to the terms of any such paid service contract or paid warranty extension.

This emissions limited warranty covers components whose failure increases the vehicle's regulated emissions, and it covers components of systems whose only purpose is to control emissions. Repairing or replacing other components not covered by this warranty is the responsibility of the vehicle owner. This emissions limited warranty does not cover components whose failure does not increase the vehicle's regulated emissions.

For exhaust emissions, emission-related components include any engine parts related to the following systems:

- Air-induction system
- Fuel system
- Ignition system
- Exhaust gas recirculation systems

The following parts are also considered emission-related components for exhaust emissions:

- Aftertreatment devices
- Crankcase ventilation valves
- Sensors
- Electronic control units

The following parts are considered emission-related components for evaporative emissions:

- Fuel Tank
- Fuel Cap
- Fuel Line
- Fuel Line Fittings
- Clamps*
- Pressure Relief Valves*
- Control Valves*
- Control Solenoids*
- Electronic Controls*
- Vacuum Control Diaphragms*
- Control Cables*
- Control Linkages*
- Purge Valves
- Vapor Hoses
- Liquid/Vapor Separator
- Carbon Canister
- Canister Mounting Brackets
- Carburetor Purge Port Connector

*As related to the evaporative emission control system.

Emission-related components also include any other part whose only purpose is to reduce emissions or whose failure will increase emissions without significantly degrading engine/equipment performance. The exclusive remedy for breach of this limited warranty shall be, at the exclusive option of POLARIS, repair or replacement of any defective materials, components or products. THE REMEDIES SET FORTH IN THIS LIMITED WARRANTY ARE THE ONLY REMEDIES AVAILABLE TO ANY PERSON FOR BREACH OF THIS WARRANTY. POLARIS SHALL HAVE NO LIABILITY TO ANY PERSON FOR INCIDENTAL, CONSEQUENTIAL OR SPECIAL DAMAGES OF ANY DESCRIPTION, WHETHER ARISING OUT OF EXPRESS OR IMPLIED WARRANTY OR ANY OTHER CONTRACT, NEGLIGENCE OR OTHER TORT OR OTHERWISE. THIS EXCLUSION OF CONSEQUENTIAL, INCIDENTAL, AND SPECIAL DAMAGES IS INDEPENDENT FROM AND SHALL SURVIVE ANY FINDING THAT THE EXCLUSIVE REMEDY FAILED OF ITS ESSENTIAL PURPOSE.

ALL IMPLIED WARRANTIES (INCLUDING BUT NOT LIMITED TO ANY IMPLIED WARRANTIES OF MERCHANTABILITY AND FITNESS FOR A PARTICULAR PURPOSE) ARE LIMITED IN DURATION TO THE WARRANTY PERIOD DESCRIBED HEREIN. POLARIS DISCLAIMS ALL EXPRESS WARRANTIES NOT STATED IN THIS WARRANTY. Some states do not allow limitations on how long an implied warranty lasts, so the above limitation may not apply if it is inconsistent with the controlling state law.

This limited warranty excludes failures not caused by a defect in material or workmanship. This limited warranty does not cover damage due to accidents, abuse or improper handling, maintenance or use. This limited warranty also does not cover any engine that has been structurally altered, or when the vehicle has been used in racing competition. This limited warranty also does not cover physical damage, corrosion or defects caused by fire, explosions or other similar causes beyond the control of POLARIS.

WARRANTY

Owners are responsible for performing the scheduled maintenance identified in the owner's manual. POLARIS may deny warranty claims for failures that have been caused by the owner's or operator's improper maintenance or use, by accidents for which POLARIS has no responsibility, or by acts of God.

Any qualified repair shop or person may maintain, replace, or repair the emission control devices or systems on your vehicle. An authorized POLARIS dealer can perform any service that may be necessary for your vehicle. POLARIS also recommends POLARIS parts, however equivalent parts may be used for such service. It is a potential violation of the Clean Air Act if a part supplied by an aftermarket parts manufacturer reduces the effectiveness of the vehicle's emission controls. Tampering with emission controls is prohibited by federal law.

CALIFORNIA RESIDENTS

Certain POLARIS Off-Road Vehicles are available in 49-state and 50-state versions. Only the 50-state models are certified for sale in California. The 50-state models available for sale in California are identified by the letter "B" in the ninth position of the model number (e.g., R16RTE87B). The POLARIS 50-state models are designed and built with features such as a reduced cargo box capacity. Any modifications to these features may be a violation of the applicable California regulations and may void this limited emissions warranty offered by the manufacturer.

If you have any questions regarding your warranty rights and responsibilities, please contact POLARIS Customer Assistance:

United States & Canada: 1-800-POLARIS (1-800-765-2747)

French: 1-800-268-6334

A	
Accelerator Pedal	43
Age Restrictions	20
Auxiliary 12-Volt Terminal Board ...	45
Axle and Wheel Nut Torque Specifications.....	85
B	
Batteries	35
Battery	89
Battery Charging	90
Battery Conditioning	36
Battery Discharge Indicator.....	30
Battery Fluid	92
Battery Handling Precautions	35
Battery Operation Range.....	37
Battery Replacement.....	91
Boots	13
Brake Fluid.....	82
Brake Inspection	83
Brake Lights	88
Brake Pedal	42
Brake System Break-in	48
Brakes	81
Break-in Period	47
C	
Cab Doors	22
Carrying a Passenger	22
Charge Status Indicator	32
Charger Operation	36
Charging Cord	45
Chrome Wheel Care (if equipped).....	93
Clean the Exterior	95
Clothing.....	13
Component Locations.....	29
Crossing Hillsides	24
D	
Descending Hills Improperly	24
Direction Selector Switch	34
Drive Mode	56
Drive Mode Switch.....	33
Driving Downhill	53
Driving in Reverse	55
Driving on a Sidehill	54
Driving on Slippery Surfaces	52
Driving Over Obstacles	53
Driving Through Water.....	54
Driving Uphill	53
Driving with a Passenger.....	51
Dumping the Cargo Box.....	59
E	
Electronic Power Steering	42
Emissions Limited Warranty.....	110
Engine and Drivetrain Break-in	47
European Vibration and Noise	8
Exported Products	109
Eye Protection	13
F	
Failure to Inspect Before Operating	21
Fluid Levels	95
Fluid Part Numbers	101
Front Gearcase.....	80
Fuel Transport Warning.....	16
G	
Gear Selector	39
Gearcase Specification Chart.....	78
Gloves	13
H	
Hauling Cargo.....	58
Headlight Beam Adjustment	88
Headlight Lamp Replacement	87
Headlight Switch	35
Helmet	13

Hot Drive Systems	26
Hour Meter	32
How To Obtain Warranty Service	108

I

Improper Cargo Loading	25
Improper Tire Maintenance	23

K

Key Switch	33
Know Your Riding Area/Tread Lightly	50

L

Lights	86
Limited Warranty	105
Lubricants / Service Products	101
Lubrication Recommendations	77

M

Main Gearcase	78
Main Power Connector	37
Maintenance	75
Maintenance Chart Key	75
Maintenance Log	113
Modifications to Vehicle	27

N

New Operator Driving Procedures	50
---------------------------------------	----

O

Obstacles	53
Operating Improperly in Reverse	24
Operating Over Obstacles	25

Operating Through Water	25
Operating With a Load on the Vehicle	22
Operating Without Instruction	20
Operator Safety	18

P

Park Brake Lever	40
Parking on an Incline	55
Parking the Vehicle	55
Part Numbers	101
Periodic Maintenance Chart	76
Polaris Products	101
Polishing the Vehicle	93
Poor Visibility	26
Power Steering	42
Pre-Ride Inspection	48
Precautions During Maintenance	27
Proper Use Warning	15
Protective Apparel	21
PVT Break-in (Clutches/Belt)	48

R

Registration, Warranty	105
Removal from Storage	95
Removing Corrosion	94
Reverse Operation	55
Rollover Protective Structure (ROPS)	45

S

Safe Operation Practices	49
Safe Riding Gear	12
Safety Labels	14
Safety Labels and Locations	14
Safety Symbols	7
Safety Training	11
Safety Warnings	20
Safety, Winch Maintenance	73
Seat Belt	43
Seat Belt / Driver Warning	15

Seat Removal	43	Winch Shock Loading.....	71
Severe Use Definition	75		
Shock Loading the Winch	71		
Signal Words	7		
Specifications	97		
Stalling While Climbing a Hill.....	24		
Steering Wheel	41		
Steering Wheel Inspection	83		
Storage	94		
Storage Area	95		
Suspension Adjustment	84		

T

Tire Tread Depth	85
Tires	84
Towing Loads	60
Towing the Vehicle	61
Trail Etiquette	50
Trailer Receiver Hitch Bracket	38
Transporting the Vehicle.....	60, 96
Turning Improperly.....	23

U

Unauthorized Use of the Vehicle ...	26
-------------------------------------	----

V

Vehicle Identification Numbers	9
Ventilation When Charging Batteries	26

W

Warning Symbols	7
Washing the Vehicle.....	92
Wheel Installation	86
Wheel Removal.....	86
Winch Cable Care	70
Winch Maintenance and Service Safety	73
Winch Operation	64
Winch Safety Precautions	63



*For your nearest Polaris dealer,
call 1-800-POLARIS (765-2747)
or visit www.polaris.com*

*Polaris Industries Inc.
2100 Highway 55
Medina, MN 55340*

*Part No. 9928293 Rev 02
Printed in USA*

