



**MERCURY**<sup>®</sup>



**Outboard  
Operation  
Maintenance  
Warranty  
Manual**



**Declaration of Conformity - For Recreational Craft Propulsion Engines with the Requirements of Directive 94/25/EC as amended by Directive 2003/44/EC**

**Name of engine manufacturer:** Mercury Marine  
**Address:** W6250 Pioneer Road, P.O. Box 1939  
**Town:** Fond du Lac, WI      **Post Code:** 54936-1939      **Country:** USA

**Name of authorized representative:** Brunswick Marine in EMEA Inc.  
**Address:** Parc Industriel de Petit-Rechain  
**Town:** Verviers      **Post Code:** B-4800      **Country:** Belgium

**Name of notified body for exhaust emission assessment:** Det Norske Veritas AS  
**Address:** Veritasveien 1  
**Town:** Hovik      **Post Code:** 1322      **Country:** Norway      **ID Number:** 0575

**Name of notified body for noise emission assessment:** Det Norske Veritas AS  
**Address:** Veritasveien 1  
**Town:** Hovik      **Post Code:** 1322      **Country:** Norway      **ID Number:** 0575

**Conformity assessment module used for exhaust emissions:**       B+C     B+D     B+E     B+F     G     H

**Conformity assessment module used for noise emissions:**       A     Aa     G     H

**Other Community Directives applied: Safety of Machinery Directive 2006/42/EC; Electromagnetic Compatibility Directive 2004/108/EC**

**Description of Engines and Essential Requirements**

<b>Engine Type</b>	<b>Fuel Type</b>	<b>Combustion Cycle</b>
<input checked="" type="checkbox"/> Outboard engine	<input checked="" type="checkbox"/> Petrol	<input checked="" type="checkbox"/> 4 stroke

## Identification of Engines Covered by This Declaration of Conformity

Name of engine family	Unique engine identification number: starting serial number	EC Module H certificate number
Verado 6 cylinder 200, 225, 250, 275, 300, 350, 400R hp	0P401000 or 1B227000	RCD-H-2 Rev 4
Verado 4 cylinder 135, 150, 175, 200 hp	0P401000 or 1B227000	RCD-H-2 Rev 4
L4NA 4 cylinder 75, 80, 90, 100, 115 hp (2.1L)	2B000000	RCD-H-2 Rev 4
150 HP FourStroke (3.0L)	0P401000 or 1B227000	RCD-H-2 Rev 4

Essential requirements	Standards	Other normative document/ method	Technical file	Please specify in more detail (* = mandatory standard)
<b>Annex 1.B—Exhaust Emissions</b>				
B.1 engine identification	<input type="checkbox"/>	<input type="checkbox"/>	<input checked="" type="checkbox"/>	
B.2 exhaust emission requirements	<input checked="" type="checkbox"/> *	<input type="checkbox"/>	<input type="checkbox"/>	* EN ISO 8178-1:1996
B.3 durability	<input type="checkbox"/>	<input type="checkbox"/>	<input checked="" type="checkbox"/>	EN ISO 8178-1:1996
B.4 owner's manual	<input checked="" type="checkbox"/>	<input type="checkbox"/>	<input type="checkbox"/>	ISO 8665: 2006
<b>Annex 1.C—Noise Emissions</b>				
C.1 Noise emission levels	<input checked="" type="checkbox"/> *	<input type="checkbox"/>	<input type="checkbox"/>	EN ISO 14509
C.2 Owner's manual	<input type="checkbox"/>	<input checked="" type="checkbox"/>	<input type="checkbox"/>	Owner's manual

This declaration of conformity is issued under the sole responsibility of the manufacturer. I declare on behalf of the engine manufacturer that the engines mentioned preceding complies with all applicable essential requirements in the way specified.

**Name / function:**

John Pfeifer, President,  
Mercury Marine

**Date and place of issue:**

December 04, 2014  
Fond du Lac, Wisconsin, USA

**Welcome**

You have selected one of the finest outboards available. It incorporates numerous design features to ensure operating ease and durability.

With proper care and maintenance, you will thoroughly enjoy using this product for many boating seasons. To ensure maximum performance and carefree use, we ask that you thoroughly read this manual.

The Operation, Maintenance and Warranty Manual contains specific instructions for using and maintaining your product. We suggest that this manual remain with the product for ready reference whenever you are on the water.

Thank you for purchasing one of our products. We sincerely hope your boating will be pleasant!

Mercury Marine

**EPA Emissions Regulations**

Outboards sold by Mercury Marine in the United States are certified to the United States Environmental Protection Agency as conforming to the requirements of the regulations for the control of air pollution from new outboard motors. This certification is contingent on certain adjustments being set to factory standards. For this reason, the factory procedure for servicing the product must be strictly followed and, wherever practicable, returned to the original intent of the design. Maintenance, replacement, or repair of the emission control devices and systems may be performed by any marine engine repair establishment or individual.

Engines are labeled with an Emission Control Information decal as permanent evidence of EPA certification.

**▲ WARNING**

**The engine exhaust from this product contains chemicals known to the state of California to cause cancer, birth defects or other reproductive harm.**

## Warranty Message

The product you have purchased comes with a limited warranty from Mercury Marine. The terms of the warranty are set forth in the **Warranty Information** section of this manual. The warranty statement contains a description of what is covered, what is not covered, the duration of coverage, how to best obtain warranty coverage, important disclaimers and limitations of damages, and other related information. Please review this important information.

The description and specifications contained herein were in effect at the time this manual was approved for printing. Mercury Marine, whose policy is one of continued improvement, reserves the right to discontinue models at any time, to change specifications, designs, methods, or procedures without notice and without incurring obligation.

Mercury Marine, Fond du Lac, Wisconsin U.S.A.

## Mercury Premier Service

Mercury evaluates the service performance of its dealers and assigns its highest rating of Mercury Premier to those demonstrating an exceptional commitment to service.

### Earning a Mercury Premier Service rating means a dealer:

- Achieves a high 12-month service Customer Satisfaction Index (CSI) score for warranty service.
- Possesses all of the necessary service tools, test equipment, manuals, and parts books.
- Employs at least one certified or master technician.
- Provides timely service for all Mercury Marine customers.
- Offers extended service hours and mobile service, when appropriate.
- Uses, displays, and stocks an adequate inventory of genuine Mercury Precision Parts.
- Offers a clean, neat shop with well-organized tools and service literature.

## Copyright and Trademark Information

© **MERCURY MARINE. All rights reserved. Reproduction in whole or in part without permission is prohibited.**

Alpha, Axius, Bravo One, Bravo Two, Bravo Three, Circle M with Waves Logo, K-planes, Mariner, MerCathode, MerCruiser, Mercury, Mercury with Waves Logo, Mercury Marine, Mercury Precision Parts, Mercury Propellers, Mercury Racing, MotorGuide, OptiMax, Quicksilver, SeaCore, Skyhook, SmartCraft, Sport-Jet, Verado, VesselView, Zero Effort, Zeus, #1 On the Water and We're Driven to Win are registered trademarks of Brunswick Corporation. Pro XS is a trademark of Brunswick Corporation. Mercury Product Protection is a registered service mark of Brunswick Corporation.

---

## WARRANTY INFORMATION

---

Warranty Registration United States and Canada.....	1
Transfer of Warranty United States and Canada.....	1
Transfer of Mercury Product Protection (Extended Service Coverage) Plan United States and Canada.....	2
3 Year Limited Warranty Against Corrosion.....	2
Warranty Coverage and Exclusions.....	4
U.S. EPA Emissions Limited Warranty.....	6
Emission Control System Components.....	6
California Emissions Limited Warranty.....	7
California Air Resources Board Explanation of Your California Emission Control Warranty Statement.....	9
Emission Certification Star Label.....	10
Warranty Policy—Australia and New Zealand.....	11
Global Warranty Charts Outboard and Jets.....	15

---

### General Information

---

Boater's Responsibilities.....	20
Before Operating Your Outboard.....	20
Boat Horsepower Capacity.....	20
High-Speed and High-Performance Boat Operation.....	21
Outboard Remote Control Models .....	21
Lanyard Stop Switch.....	21
Protecting People in the Water.....	24
Exhaust Emissions.....	24
Passenger Safety Message - Pontoon Boats and Deck Boats.....	26
Wave and Wake Jumping.....	28
Impact with Underwater Hazards.....	29
Selecting Accessories for Your Outboard.....	30
Safe Boating Recommendations.....	30
Specifications.....	33
Recording Serial Number.....	35
Component Identification 200–300.....	35
350 HP Component Identification.....	36
Propeller Selection.....	36

---

### Transporting

---

Trailer Boat/Outboard .....	39
-----------------------------	----

---

## Fuel and Oil

---

Fuel Recommendations.....	41
Fuel Additives.....	42
Low Permeation Fuel Hose Requirement .....	42
Fuel Demand Valve.....	43
Engine Oil Recommendations.....	43
Checking and Adding Engine Oil.....	44

---

## Features and Controls

---

Panel Mount Control Features and Operation.....	46
Slim Binnacle Control Features and Operation.....	48
Dual-Handle Console Control Features and Operation.....	54
Shadow Mode Control with CAN Trackpad Features and Operation.....	62
Hot Foot.....	65
Zero Effort Controls.....	68
Warning System.....	68
Power Trim and Tilt.....	70

---

## Operation

---

Important Daily Inspection Before Each Use .....	74
Prestarting Check List.....	74
Operating in Freezing Temperatures.....	75
Operating in Saltwater or Polluted Water.....	75
Operating at High Elevations.....	75
Propeller Selection.....	75
Effects of Elevation and Weather on Performance.....	76
Setting Trim Angle While Running Engine at Idle Speed.....	77
Engine Break-in Procedure.....	77
Fuel Supply Module Priming Procedure.....	77
Starting the Engine.....	79
Gear Shifting.....	82
Stopping the Engine.....	84



---

## Maintenance

---

Outboard Care.....	85
EPA Emissions Regulations.....	85
Inspection and Maintenance Schedule.....	86
Flushing the Cooling System.....	89
Cowl Removal and Installation.....	89
Cleaning Care for Top and Bottom Cows.....	91
Cleaning Care for the Powerhead (Saltwater Use).....	92
Battery Inspection .....	92
Verado Engine Battery Specifications.....	92
Air Filter (200–300).....	94
Air Filter (350, 350 Pro).....	95
Fuel System.....	95
Corrosion Control Anodes.....	98
Trim Wear Pad Replacement.....	99
Propeller Replacement.....	100
Spark Plug Inspection and Replacement.....	103
Fuses.....	105
DTS Wiring System.....	107
Accessory Drive Belt Inspection.....	107
Checking Power Trim Fluid.....	108
Checking Power Steering Fluid.....	109
Changing Engine Oil .....	109
Gearcase Lubrication.....	112

---

## Storage

---

Storage Preparation.....	118
Protecting External Outboard Components.....	118
Protecting Internal Engine Components.....	118
Gearcase.....	119
Positioning Outboard for Storage.....	119
Battery Storage.....	119

---

## Troubleshooting

---

Starter Motor Will Not Crank the Engine.....	120
Engine Will Not Start.....	120
Engine Starts But Will Not Shift Into Gear.....	120
Engine Runs Erratically.....	120
Performance Loss.....	121
Battery Will Not Hold Charge.....	121

---

## Owner Service Assistance

---

Service Assistance.....	122
Ordering Literature.....	124

---

## Installation

---

Outboard Installation.....	126
----------------------------	-----

---

## Maintenance Log

---

Maintenance Log.....	133
----------------------	-----

# WARRANTY INFORMATION

## Warranty Registration United States and Canada

To be eligible for warranty coverage, the product must be registered with Mercury Marine.

At the time of sale, the selling dealer should complete the warranty registration and immediately submit it to Mercury Marine via MercNET, e-mail, or mail. Upon receipt of this warranty registration, Mercury Marine will record the registration.

A copy of the warranty registration should be provided to you by your selling dealer.

**NOTE:** *Registration lists must be maintained by Mercury Marine and any dealer of Mercury Marine products sold in the United States, should a safety recall notification under the Federal Safety Act be required.*

You may change your registered address at any time, including at time of warranty claim, by calling Mercury Marine or sending a letter or fax with your name, old address, new address, and engine serial number to Mercury Marine's warranty registration department. Your dealer can also process this change of information.

Mercury Marine  
Attn: Warranty Registration Department  
W6250 Pioneer Road  
P.O. Box 1939  
Fond du Lac, WI 54936-1939  
920-929-5054  
Fax +1 920 907 6663

## OUTSIDE UNITED STATES AND CANADA

For products purchased outside the United States and Canada, contact the distributor in your country, or the Marine Power Service Center closest to you.

## Transfer of Warranty United States and Canada

The limited warranty is transferable to a subsequent purchaser, but only for the remainder of the unused portion of the limited warranty. This will not apply to products used for commercial applications.

To transfer the warranty to the subsequent owner, send or fax a copy of the bill of sale or purchase agreement, new owner's name, address, and engine serial number to Mercury Marine's warranty registration department. In the United States and Canada, mail to:

Mercury Marine  
Attn: Warranty Registration Department  
W6250 Pioneer Road  
P.O. Box 1939  
Fond du Lac, WI 54936-1939  
920-929-5054  
Fax +1 920 907 6663

# WARRANTY INFORMATION

Upon processing the transfer of warranty, Mercury Marine will record the new owner's information.

There is no charge for this service.

## **OUTSIDE THE UNITED STATES AND CANADA**

For products purchased outside the United States and Canada, contact the distributor in your country, or the Marine Power Service Center closest to you.

## **Transfer of Mercury Product Protection (Extended Service Coverage) Plan United States and Canada**

The remaining coverage period of the Product Protection Plan is transferable to the subsequent purchaser of the engine within thirty (30) days from the date of sale. Contracts not transferred within thirty (30) days of the subsequent purchase will no longer be valid and the product will no longer be eligible for coverage under the terms of the contract.

To transfer the plan to the subsequent owner, contact Mercury Product Protection or an authorized dealer to receive a Request for Transfer form. Submit to Mercury Product Protection a receipt/bill of sale, a completed Request of Transfer form, and a check payable to Mercury Marine in the amount of \$50.00 (per engine) to cover the transfer fee.

Plan coverage is not transferable from one product to another product or for noneligible applications.

The certified preowned engine plans are not transferable.

For help or assistance, contact Mercury Product Protection Department at 1-888-427-5373 from 7:30 a.m. to 4:30 p.m. CST, Monday–Friday or e-mail [mpp\\_support@mercmarine.com](mailto:mpp_support@mercmarine.com).

## **3 Year Limited Warranty Against Corrosion**

**WHAT IS COVERED:** Mercury Marine warrants that each new Mercury, Mariner, Mercury Racing Outboards, Sport-Jet, M<sup>2</sup> Jet Drive, Tracker by Mercury Marine Outboard, Mercury MerCruiser Inboard or Sterndrive Engine (Product) will not be rendered inoperative as a direct result of corrosion for the period of time described below.

**DURATION OF COVERAGE:** This limited corrosion warranty provides coverage for three (3) years from either the date the product is first sold, or the date on which the product is first put into service, whichever occurs first. The repair or replacement of parts, or the performance of service under this warranty, does not extend the life of this warranty beyond its original expiration date. Unexpired warranty coverage can be transferred to subsequent (noncommercial use) purchaser upon proper reregistration of the product.

# WARRANTY INFORMATION

## **CONDITIONS THAT MUST BE MET IN ORDER TO OBTAIN WARRANTY**

**COVERAGE:** Warranty coverage is available only to retail customers that purchase from a Dealer authorized by Mercury Marine to distribute the product in the country in which the sale occurred, and then only after the Mercury Marine specified pre-delivery inspection process is completed and documented. Warranty coverage becomes available upon proper registration of the product by the authorized dealer. Corrosion prevention devices specified in the Operation and Maintenance Manual must be in use on the boat, and routine maintenance outlined in the Operation and Maintenance Manual must be timely performed (including, without limitation, the replacement of sacrificial anodes, use of specified lubricants, and touch-up of nicks and scratches) in order to maintain warranty coverage. Mercury Marine reserves the right to make warranty coverage contingent upon proof of proper maintenance.

**WHAT MERCURY WILL DO:** Mercury Marine's sole and exclusive obligation under this warranty is limited to, at our option, repairing a corroded part, replacing such part or parts with new or Mercury Marine certified remanufactured parts, or refunding the purchase price of the Mercury Marine product. Mercury Marine reserves the right to improve or modify products from time to time without assuming an obligation to modify products previously manufactured.

**HOW TO OBTAIN WARRANTY COVERAGE:** The customer must provide Mercury Marine with a reasonable opportunity to repair, and reasonable access to the product for warranty service. Warranty claims shall be made by delivering the product for inspection to a Mercury Marine dealer authorized to service the product. If the purchaser cannot deliver the product to such a dealer, written notice must be given to Mercury Marine. Mercury Marine will then arrange for the inspection and any covered repair. The purchaser, in that case, shall pay for all related transportation charges and travel time. If the service provided is not covered by this warranty, the purchaser shall pay for all related labor and material, and any other expenses associated with that service. The purchaser shall not, unless requested by Mercury Marine, ship the product or parts of the product directly to Mercury Marine. Proof of registered ownership must be presented to the dealer at the time warranty service is requested in order to obtain coverage.

**WHAT IS NOT COVERED:** This limited warranty does not cover electrical system corrosion; corrosion resulting from damage, corrosion which causes purely cosmetic damage, abuse, or improper service; corrosion to accessories, instruments, steering systems; corrosion to factory installed jet drive unit; damage due to marine growth; product sold with less than a one year limited Product warranty; replacement parts (parts purchased by customer); products used in a commercial application. Commercial use is defined as any work or employment related use of the product, or any use of the product which generates income, for any part of the warranty period, even if the product is only occasionally used for such purposes.

# WARRANTY INFORMATION

Corrosion damage caused by stray electrical currents (onshore power connections, nearby boats, submerged metal) is not covered by this corrosion warranty and should be protected against by the use of a corrosion protection system, such as the Mercury Precision Parts or Quicksilver MerCathode system and/or Galvanic Isolator. Corrosion damage caused by improper application of copper base antifouling paints is also not covered by this limited warranty. If antifouling protection is required, Tri-Butyl-Tin-Adipate (TBTA) base antifouling paints are recommended on Outboard and MerCruiser boating applications. In areas where TBTA base paints are prohibited by law, copper base paints can be used on the hull and transom. Do not apply paint to the Outboard or MerCruiser product. In addition, care must be taken to avoid an electrical interconnection between the warranted product and the paint. For MerCruiser product, an unpainted gap of at least 38 mm (1.5 in.) should be left around the transom assembly. Refer to the Operation and Maintenance Manual for additional details.

For additional information regarding events and circumstances covered by this warranty, and those that are not, see the Warranty Coverage section of the Operation and Maintenance Manual, incorporated by reference into this warranty.

## **DISCLAIMERS AND LIMITATIONS:**

**THE IMPLIED WARRANTIES OF MERCHANTABILITY AND FITNESS FOR A PARTICULAR PURPOSE ARE EXPRESSLY DISCLAIMED. TO THE EXTENT THAT THEY CANNOT BE DISCLAIMED, THE IMPLIED WARRANTIES ARE LIMITED IN DURATION TO THE LIFE OF THE EXPRESS WARRANTY. INCIDENTAL AND CONSEQUENTIAL DAMAGES ARE EXCLUDED FROM COVERAGE UNDER THIS WARRANTY. SOME STATES/COUNTRIES DO NOT ALLOW FOR THE DISCLAIMERS, LIMITATIONS AND EXCLUSIONS IDENTIFIED ABOVE, AS A RESULT, THEY MAY NOT APPLY TO YOU. THIS WARRANTY GIVES YOU SPECIFIC LEGAL RIGHTS, AND YOU MAY ALSO HAVE OTHER LEGAL RIGHTS WHICH VARY FROM STATE TO STATE AND COUNTRY TO COUNTRY.**

## **Warranty Coverage and Exclusions**

The purpose of this section is to help eliminate some of the more common misunderstandings regarding warranty coverage. The following information explains some of the types of services that are not covered by warranty. The provisions set forth following have been incorporated by reference into the Three Year Limited Warranty Against Corrosion Failure, the International Limited Outboard Warranty, and the United States and Canada Limited Outboard Warranty.

Keep in mind that warranty covers repairs that are needed within the warranty period because of defects in material and workmanship. Installation errors, accidents, normal wear, and a variety of other causes that affect the product are not covered.

# WARRANTY INFORMATION

Warranty is limited to defects in material or workmanship, but only when the consumer sale is made in the country to which distribution is authorized by us. Should you have any questions concerning warranty coverage, contact your authorized dealer. They will be pleased to answer any questions that you may have.

## GENERAL EXCLUSIONS FROM WARRANTY

1. Minor adjustments and tune-ups, including checking, cleaning, or adjusting spark plugs, ignition components, carburetor settings, filters, belts, controls, and checking lubrication made in connection with normal services.
2. Installation errors, accidents, normal wear and tear, and faded paint.
3. Factory installed jet drive units - Specific parts excluded from the warranty are: the jet drive impeller and jet drive liner damaged by impact or wear, and water damaged driveshaft bearings as a result of improper maintenance.
4. Damage caused by neglect, lack of maintenance, accident, abnormal operation, or improper installation or service.
5. Haul-out, launch, towing charges, removal and/or replacement of boat partitions or material because of boat design for necessary access to the product, all related transportation charges and/or travel time, etc. Reasonable access must be provided to the product for warranty service. Customer must deliver product to an authorized dealer.
6. Additional service work requested by customer other than that necessary to satisfy the warranty obligation.
7. Labor performed by other than an authorized dealer may be covered only under the following circumstances: when performed on emergency basis (providing there are no authorized dealers in the area who can perform the work required or have no facilities to haul-out, etc., and prior factory approval has been given to have the work performed at this facility).
8. All incidental and/or consequential damages (storage charges, telephone or rental charges of any type, inconvenience or loss of time or income) are the owner's responsibility.
9. Use of other than Mercury Precision or Quicksilver parts when making warranty repairs.
10. Oils, lubricants, or fluids changed as a matter of normal maintenance is customer's responsibility unless loss or contamination of same is caused by product failure that would be eligible for warranty consideration.
11. Participating in or preparing for racing or other competitive activity or operating with a racing type lower unit.
12. Engine noise does not necessarily indicate a serious engine problem. If diagnosis indicates a serious internal engine condition which could result in a failure, condition responsible for noise should be corrected under the warranty.

# WARRANTY INFORMATION

13. Lower unit and/or propeller damage caused by striking a submerged object is considered a marine hazard.
14. Water entering engine through the fuel intake, air intake, or exhaust system or submersion.
15. Failure of any parts caused by lack of cooling water, which results from starting motor out of water, foreign material blocking inlet holes, motor being mounted too high, or trimmed too far out.
16. Use of fuels and lubricants which are not suitable for use with or on the product. Refer to the **Maintenance** section.
17. Our limited warranty does not apply to any damage to our products caused by the installation or use of parts and accessories which are not manufactured or sold by us. Failures which are not related to the use of those parts or accessories are covered under warranty if they otherwise meet the terms of the limited warranty for that product.

## U.S. EPA Emissions Limited Warranty

Consistent with the obligations created by 40 CFR Part 1045, Subpart B, Mercury Marine provides a five year or 175 hours of engine use warranty, whichever occurs first, to the retail customer, that the engine is designed, built, and equipped so as to conform at the time of sale with applicable regulations under section 213 of the Clean Air Act, and that the engine is free from defects in materials and workmanship that cause the engine to fail to conform with applicable regulations. This emission-related warranty covers all the components listed in the **Emission Control System Components**.

## Emission Control System Components

The EPA and California emission-related warranty covers all the following list of components:

### COMPONENTS OF THE EMISSIONS CONTROL SYSTEM:

1. Fuel metering system
  - a. Carburetor and internal parts (and/or pressure regulator or fuel injection system)
  - b. Cold start enrichment system
  - c. Intake valves
2. Air induction system
  - a. Intake manifold
  - b. Turbocharger or supercharger systems (where applicable)
3. Ignition system
  - a. Spark plugs
  - b. Magneto or electronic ignition system
  - c. Spark advance/retard system
  - d. Ignition coil and/or control module



# WARRANTY INFORMATION

- e. Ignition wires
- 4. Lubrication system (4-Stroke engines excluded)
  - a. Oil pump and internal parts
  - b. Oil injectors
  - c. Oil meter
- 5. Exhaust system
  - a. Exhaust manifold
  - b. Exhaust valves
- 6. Miscellaneous items used in above systems
  - a. Hoses, clamps, fittings, tubing, sealing gaskets or devices, and mounting hardware
  - b. Pulleys, belts, and idlers
  - c. Vacuum, temperature, check and time sensitive valves and switches
  - d. Electronic controls

The emission-related warranty does not cover components whose failure would not increase an engine's emissions on any regulated pollutant.

## California Emissions Limited Warranty

The California Air Resources Board has promulgated air emission regulations for outboard engines. The regulations apply to all outboard engines sold to retail consumers in California, and which were manufactured for the 2001 model year and later. Mercury Marine, in compliance with those regulations, provides this limited warranty for the emission control systems (see the components listed in the **Emission Control System Components**), and further warrants that the outboard engine was designed, built, and equipped to conform with all applicable regulations adopted by the California Air Resources Board pursuant to its authority in Chapters 1 and 2, Part 5, Division 26 of the Health and Safety Code. For information regarding the limited warranty for the nonemission-related components of the outboard, please see the limited warranty statement for your outboard.

**WHAT IS COVERED:** Mercury Marine warrants the components of the emissions control systems (see the components listed in the **Emission Control System Components**) of its new, 2001 model year and later outboards, sold by a California dealer to retail customers residing in California, to be free from defects in material or workmanship, that cause the failure of a warranted part to be identical in all material respects to that part as described in the application of Mercury Marine for certification from the California Air Resources Board, for the period of time, and under the conditions, identified below. The cost to diagnose a warranty failure is covered under the warranty (if the warranty claim is approved). Damage to other engine components caused by the failure of a warranted part will also be repaired under warranty.

# WARRANTY INFORMATION

**DURATION OF COVERAGE:** This limited warranty provides coverage for the components of the emissions control systems of new, 2001 model year and later outboards, sold to retail customers in California for four (4) years from either the date the product is first sold, or first put into service, whichever occurs first, or the accumulation of 250 hours of engine operation (as determined by the engine's hour meter, if any). Emission-related normal maintenance items such as spark plugs and filters, that are on the warranted parts list, are warranted up to their first required replacement interval only.

Refer to **Emission Control System Components and Maintenance Schedule**. The repair or replacement of parts, or the performance of service under this warranty, does not extend the life of this warranty beyond its original expiration date. Unexpired warranty coverage can be transferred to a subsequent purchaser. (See instructions on transfer of warranty.)

**HOW TO OBTAIN WARRANTY COVERAGE:** The customer must provide Mercury with a reasonable opportunity to repair and reasonable access to the product for warranty service. Warranty claims shall be made by delivering the product for inspection to a Mercury dealer authorized to service the product. If purchaser cannot deliver the product to such a dealer, please notify Mercury Marine and Mercury will then arrange for the inspection and any covered repair. Purchaser, in that case, shall pay for all related transportation charges and/or travel time. If the service provided is not covered by this warranty, purchaser shall pay for all related labor and material, and any other expenses associated with that service. Purchaser shall not, unless requested by Mercury, ship the product or parts of the product directly to Mercury.

**WHAT MERCURY WILL DO:** Mercury Marine's sole and exclusive obligation under this warranty is limited to, at our expense and at our option, repairing or replacing defective parts with new or Mercury Marine certified remanufactured parts, or refunding the purchase price of the Mercury product. Mercury reserves the right to improve or modify products from time to time without assuming an obligation to modify products previously manufactured.

**WHAT IS NOT COVERED:** This limited warranty does not cover routine maintenance items, tune-ups, adjustments, normal wear and tear, damage caused by abuse, abnormal use, use of a propeller or gear ratio that does not allow the engine to run in its recommended wide-open throttle RPM range (see **General Information - Specifications**), operation of the product in a manner inconsistent with the recommended operation procedures, neglect, accident, submersion, improper installation (proper installation specifications and techniques are set forth in the installation instructions for the product), improper service, jet pump impellers and liners, operation with fuels, oils, or lubricants which are not suitable for use with the product (see **Fuel and Oil**), alteration or removal of parts.

# WARRANTY INFORMATION

Expenses related to haul-out, launch, towing, storage, telephone, rental, inconvenience, slip fees, insurance coverage, loan payments, loss of time, loss of income, or any other type of incidental or consequential damages are not covered by this warranty. Also, expenses associated with the removal and/or replacement of boat partitions or material caused by boat design for access to the product are not covered by this warranty.

Nonwarranty maintenance, replacement, or repair of emission control devices and systems may be performed by any marine engine repair establishment or individual. The use of non-Mercury parts for nonwarranty maintenance or repairs will not be grounds for disallowing other warranty work. The use of add-on (as defined at section 1900 (b)(1) and (b)(10) of Title 13 of the California Code of Regulations) or modified parts not exempted by the California Air Resources Board may be grounds for disallowing a warranty claim, at the discretion of Mercury Marine. Failures of warranted parts caused by the use of a nonexempted add-on or modified part will not be covered.

## DISCLAIMERS AND LIMITATIONS

**THE IMPLIED WARRANTIES OF MERCHANTABILITY AND FITNESS FOR A PARTICULAR PURPOSE ARE EXPRESSLY DISCLAIMED. TO THE EXTENT THAT THEY CANNOT BE DISCLAIMED, THE IMPLIED WARRANTIES ARE LIMITED IN DURATION TO THE LIFE OF THE EXPRESS WARRANTY. INCIDENTAL AND CONSEQUENTIAL DAMAGES ARE EXCLUDED FROM COVERAGE UNDER THIS WARRANTY. SOME STATES/COUNTRIES DO NOT ALLOW FOR THE DISCLAIMERS, LIMITATIONS AND EXCLUSIONS IDENTIFIED ABOVE, AS A RESULT, THEY MAY NOT APPLY TO YOU. THIS WARRANTY GIVES YOU SPECIFIC LEGAL RIGHTS, AND YOU MAY ALSO HAVE OTHER LEGAL RIGHTS WHICH VARY FROM STATE TO STATE AND COUNTRY TO COUNTRY.**

If you have any questions regarding your warranty rights and responsibilities, you should contact Mercury Marine at 1-920-929-5040.

## California Air Resources Board Explanation of Your California Emission Control Warranty Statement

**YOUR WARRANTY RIGHTS AND OBLIGATIONS:** The California Air Resources Board is pleased to explain the emission control system warranty on your 2014–2015 model year outboard engine. In California, new outboard engines must be designed, built, and equipped to meet the State's stringent anti-smog standards. Mercury Marine must warrant the emission control system on your outboard engine for the periods of time listed below, provided there has been no abuse, neglect, or improper maintenance of your outboard engine.

Your emission control system may include parts such as the carburetor or fuel injection system, the ignition system, and catalytic converter. Also included may be hoses, belts, connectors, and other emission-related assemblies.

# WARRANTY INFORMATION

Where a warrantable condition exists, Mercury Marine will repair your outboard engine at no cost to you, including diagnosis, parts, and labor.

**MANUFACTURER'S WARRANTY COVERAGE:** Select emission control parts from model year 2001 and later outboard engines are warranted for four (4) years, or for 250 hours of use, whichever occurs first. However, warranty coverage based on the hourly period is only permitted for outboard engines and personal watercraft equipped with hour meters as defined in s 2441(a)(13) or their equivalent. If any emission-related part on your engine is defective under warranty, the part will be repaired or replaced by Mercury Marine.

**OWNER'S WARRANTY RESPONSIBILITIES:** As the outboard engine owner, you are responsible for the performance of the required maintenance listed in the **Maintenance** section. Mercury Marine recommends that you retain all receipts covering maintenance on your outboard engine, but Mercury Marine cannot deny warranty solely for the lack of receipts or your failure to ensure the performance of all scheduled maintenance.

As the outboard engine owner, you should, however, be aware that Mercury Marine may deny you warranty coverage if your outboard engine or a part has failed due to abuse, neglect, improper maintenance, or unapproved modifications.

You are responsible for presenting your outboard to a Mercury dealer authorized to service the product as soon as a problem exists. The warranty repairs will be completed in a reasonable amount of time, not to exceed 30 days.

If you have any questions regarding your warranty rights and responsibilities, you should contact Mercury Marine at 1-920-929-5040.

## Emission Certification Star Label

Outboards are labeled on the cowl with one of the following star labels.

**The symbol for a cleaner marine engine means:**



**Cleaner air and water** - for a healthier lifestyle and environment.

**Better fuel economy** - burns up to 30–40 percent less gas and oil than conventional carbureted two-stroke engines, saving money and resources.

**Longer emission warranty** - protects consumer for worry-free operation.

 The logo features a black star with a white outline, set against a white background. The star is surrounded by a black oval border. The word "LOW" is written in white capital letters at the top of the oval, and "EMISSION" is written in white capital letters at the bottom. A banner across the bottom of the oval contains the number "22531". The text "CALIFORNIA EMISSION STANDARDS" is written in small black letters around the inner edge of the oval.	<p><b>One Star - Low Emission</b></p> <p>The One Star label identifies engines that meet the Air Resources Board's 2001 exhaust emissions standards. Engines meeting these standards have 75% lower emissions than conventional carbureted two-stroke engines. These engines are equivalent to the U.S. EPA's 2006 standards for marine engines.</p>
---	--

# WARRANTY INFORMATION

 <p>42537</p>	<p><b>Two Stars - Very Low Emission</b></p> <p>The Two Star label identifies engines that meet the Air Resources Board's Personal Watercraft and Outboard marine engine 2004 exhaust emissions standards. Engines meeting these standards have 20% lower emissions than One Star - Low Emission engines.</p>
 <p>42538</p>	<p><b>Three Stars - Ultra Low Emission</b></p> <p>The Three Star label identifies engines that meet the Air Resources Board's Personal Watercraft and Outboard marine engine 2008 exhaust emissions standards or the Sterndrive and Inboard marine engine 2003-2008 exhaust emission standards. Engines meeting these standards have 65% lower emissions than One Star - Low Emission engines.</p>
 <p>42539</p>	<p><b>Four Stars - Super Ultra Low Emission</b></p> <p>The Four Star label identifies engines that meet the Air Resources Board's Sterndrive and Inboard marine engine 2009 exhaust emission standards. Personal Watercraft and Outboard marine engines may also comply with these standards. Engines meeting these standards have 90% lower emissions than One Star - Low Emission engines.</p>

## Warranty Policy—Australia and New Zealand

### MERCURY/MARINER OUTBOARD LIMITED WARRANTY—AUSTRALIA AND NEW ZEALAND POLICY

This limited warranty is given by Marine Power International Pty Ltd ACN 003 100 007 of 41–71 Bessemer Drive, Dandenong South, Victoria 3175 Australia (telephone (61) (3) 9791 5822) e-mail: [merc\\_info@mercmarine.com](mailto:merc_info@mercmarine.com).

#### What is Covered

Mercury Marine warrants its new products to be free of defects in material and workmanship during the period described following. The benefits to the consumer given by the warranty are in addition to other rights and remedies of the consumer under a law in relation to the goods or services to which the warranty relates.

# WARRANTY INFORMATION

## **Guarantees Under Australian Consumer Law**

Our goods come with guarantees that cannot be excluded under the Australian Consumer Law. You are entitled to a replacement or refund for a major failure and compensation for any other reasonably foreseeable loss or damage. You are also entitled to have the goods repaired or replaced if the goods fail to be of acceptable quality and the failure does not amount to a major failure.

## **Warranty Period for Recreational Use**

This Limited Warranty provides coverage for three (3) years from the date the product is first sold to a recreational use retail purchaser, or the date on which the product is first put into service, whichever occurs first. Unexpired warranty coverage can be transferred to a subsequent recreational use customer upon proper registration of the product.

## **Warranty Period for Commercial Use**

Commercial users of these products receive warranty coverage under this Limited Warranty of one (1) year from the date of first retail sale, or one (1) year from the date on which the product was first put into service, whichever occurs first. Commercial use is defined as any work or employment related use of the product, or any use of the product which generates income, for any part of the warranty period, even if the product is only occasionally used for such purposes. Unexpired warranty coverage cannot be transferred either to or from a commercial use customer.

## **Conditions That Must Be Met to Obtain Warranty Coverage**

Warranty coverage under this Limited Warranty is available only to retail customers that purchase from a Dealer authorized by Mercury Marine to distribute the product in the country in which the sale occurred, and then only after the Mercury Marine specified pre-delivery inspection process is completed and documented. Warranty coverage becomes available upon proper registration of the product by the authorized dealer. Inaccurate warranty registration information regarding recreational use, or subsequent change of use from recreational to commercial (unless properly registered) may void the warranty at the sole discretion of Mercury Marine. Routine maintenance outlined in the Operation and Maintenance Manual must be timely performed in order to maintain warranty coverage. Mercury Marine reserves the right to make warranty coverage contingent upon proof of proper maintenance.

## **What Mercury Will Do**

Mercury Marine's sole and exclusive obligation under this Limited Warranty is limited to, at our option, repairing a defective part, replacing such part or parts with new or Mercury Marine certified remanufactured parts, or refunding the purchase price of the Mercury Marine product. Mercury Marine reserves the right to improve or modify products from time to time without assuming an obligation to modify products previously manufactured.

# WARRANTY INFORMATION

## How to Obtain Warranty Coverage Under This Limited Warranty

The customer must provide Mercury Marine with a reasonable opportunity to repair and reasonable access to the product for warranty service. Warranty claims shall be made by delivering the product for inspection to a Mercury Marine dealer authorized to service the product. A list of dealers and their contact details is available at [www.mercurymarine.com.au](http://www.mercurymarine.com.au). If the purchaser cannot deliver the product to such a dealer, written notice must be given to Mercury Marine at the address shown above. Mercury Marine will then arrange for the inspection and any covered repair. This Limited Warranty will not cover the purchaser for all related transportation charges and travel time. If the service provided is not covered by this limited warranty, the purchaser shall pay for all related labor and material and any other expenses associated with that service, provided that a consumer will not be obligated to pay where the service has been carried out to remedy a failure of an acceptable quality guarantee which is binding on Mercury Marine under the Australian Consumer Law. The purchaser shall not, unless requested by Mercury Marine, ship the product or parts of the product directly to Mercury Marine. Proof of registered ownership must be presented to the dealer at the time warranty service is requested in order to obtain coverage under this Limited Warranty.

## What is Not Covered

This limited warranty does not cover routine maintenance items, tune-ups, adjustments, normal wear and tear, faded paint, damage caused by abuse, abnormal use, use of a propeller or gear ratio that does not allow the engine to run in its recommended wide-open throttle RPM range (see the Operation and Maintenance Manual), operation of the product in a manner inconsistent with the recommended operation/duty cycle section of the Operation and Maintenance Manual, neglect, accident, submersion, improper installation (proper installation specifications and techniques are set forth in the installation instructions for the product), improper service, use of an accessory or part not manufactured or sold by us, jet pump impellers and liners, operation with fuels, oils or lubricants that are not suitable for use with the product (see the Operation and Maintenance Manual), alteration or removal of parts, water entering the engine through the fuel intake, air intake or exhaust system, or damage to the product from insufficient cooling water caused by blockage of the cooling system by a foreign body, running the engine out of water, mounting the engine too high on the transom, or running the boat with the engine trimmed out too far. Use of the product for racing or other competitive activity, or operating with a racing type lower unit, at any point, even by a prior owner of the product, voids the warranty.

Expenses related to haul-out, launch, towing, storage, telephone, rental, inconvenience, slip fees, insurance coverage, loan payments, loss of time, loss of income, or any other type of incidental or consequential damages are not covered by this Limited Warranty. Also, expenses associated with the removal and/or replacement of boat partitions or material caused by boat design for access to the product are not covered by this warranty.

# WARRANTY INFORMATION

No individual or entity, including Mercury Marine authorized dealers, has been given authority by Mercury Marine to make any affirmation, representation or warranty regarding the product, other than those contained in this limited warranty, and if made, shall not be enforceable against Mercury Marine. For additional information regarding events and circumstances covered by this warranty, and those that are not, see the Warranty Coverage section of the Operation and Maintenance Manual, incorporated by reference into this warranty.

## **Expense of Claiming This Limited Warranty**

This Limited Warranty does not cover any expenses you may incur claiming the warranty.

<b>DISCLAIMERS AND LIMITATIONS:</b>
<b>EXCEPT FOR APPLICABLE GUARANTEES AND OTHER RIGHTS AND REMEDIES THAT A CONSUMER MAY HAVE UNDER THE AUSTRALIAN CONSUMER LAW OR OTHER LAW IN RELATION TO WHICH THE PRODUCTS RELATE, THE IMPLIED WARRANTIES OF MERCHANTABILITY AND FITNESS FOR A PARTICULAR PURPOSE ARE EXPRESSLY DISCLAIMED. TO THE EXTENT THAT THEY CANNOT BE DISCLAIMED, THE IMPLIED WARRANTIES ARE LIMITED IN DURATION TO THE LIFE OF THE EXPRESS WARRANTY. INCIDENTAL AND CONSEQUENTIAL DAMAGES ARE EXCLUDED FROM COVERAGE UNDER THIS LIMITED WARRANTY.</b>

## **TRANSFER OF WARRANTY—AUSTRALIA AND NEW ZEALAND POLICY**

The limited warranty is transferable to a subsequent purchaser, but only for the remainder of the unused portion of the limited warranty. This will not apply to products used for commercial applications.

To transfer the warranty to the subsequent owner, send or fax a copy of the Bill of Sale or Purchase Agreement, new owner's name, address, and hull identification number (HIN) to Mercury Marine's Warranty Registration Department. In Australia and New Zealand, mail to:

Mercury Marine  
Attn: Warranty Registration Department  
Brunswick Asia Pacific Group  
Private Bag 1420  
Dandenong South, Victoria 3164  
Australia

Upon processing the transfer of warranty, Mercury Marine will send registration verification to the new owner of the product by mail. There is no charge for this service.



# WARRANTY INFORMATION

You may change your address at any time, including at the time of the warranty claim, by calling Mercury Marine or sending a letter or fax with your name, old address, new address, and hull identification number (HIN) to Mercury Marine's Warranty Registration Department.

## Global Warranty Charts Outboard and Jets

### UNITED STATES WARRANTY CHARTS—OUTBOARD AND JET

Product	Standard Limited Warranty	Standard Limited Corrosion Warranty
FourStroke (2.5–350 hp including Verado, Pro FourStroke and Jet outboards)	3 years	3 years
OptiMax (75–250 hp including Pro XS and Jet outboards)	3 years	3 years
OptiMax Jet drive (200 and 250 hp)	1 year	3 years

Racing Product (Recreation use only)	Standard Limited Warranty	Standard Limited Corrosion Warranty
OptiMax (250 XS)	2 years	3 years
OptiMax (300 XS)	2 years	3 years
Verado (400R)	2 years	3 years

### Outside the United States

For product purchased outside the United States, contact the distributor in your country, or the authorized Marine Power Service Center closest to you.

### CANADA WARRANTY CHARTS—OUTBOARD AND JET

Product	Standard Limited Warranty	Standard Limited Corrosion Warranty
2-Stroke carbureted (50–90 hp)	1 year	3 years
2-Stroke EFI (150 hp)	2 years	3 years
2-Stroke carbureted (V6)	2 years	3 years
FourStroke (2.5–350 hp including Verado, Pro FourStroke and jet outboards)	3 years	3 years
OptiMax (75–250 hp including Pro XS and jet outboards)	3 years	3 years

# WARRANTY INFORMATION

Product	Standard Limited Warranty	Standard Limited Corrosion Warranty
OptiMax jet drive (200 and 250 hp)	1 year	3 years

Racing Product (Recreation use only)	Standard Limited Warranty	Standard Limited Corrosion Warranty
OptiMax (250 XS)	2 years	3 years
OptiMax (225 Sport XS)	2 years	3 years
OptiMax (300 XS)	2 years	3 years
Verado (400R)	2 years	3 years

## Outside of Canada

For product purchased outside of Canada, contact the distributor in your country, or the authorized Marine Power Service Center or dealer closest to you.

## AUSTRALIA AND NEW ZEALAND WARRANTY CHARTS—OUTBOARD AND JET

Products	Standard Limited Warranty	Standard Limited Corrosion Warranty	Light Commercial
All outboard	3 years	3 years	Contact the Marine Power Service Center closest to you

## Outside of Australia and New Zealand

For product purchased outside of Australia and New Zealand, contact the distributor in your country, or the Marine Power Service Center closest to you.

## SOUTH PACIFIC WARRANTY CHART—OUTBOARD AND JET

Products	Standard Limited Warranty	Standard Limited Corrosion Warranty	Light Commercial
All outboard	2 years	3 years	Contact the Marine Power Service Center closest to you

# WARRANTY INFORMATION

## Outside of South Pacific

For product purchased outside of the South Pacific region, contact the distributor in your country, or the Marine Power Service Center closest to you.

## ASIA WARRANTY CHARTS—OUTBOARD AND JET

Product (Recreational only)	Standard Limited Warranty	Standard Limited Corrosion Warranty	Commercial Application
2-Stroke	1 year	3 years	Contact the Marine Power Service Center closest to you
FourStroke	1 year	3 years	
OptiMax	1 year	3 years	
Verado	1 year	3 years	

Racing Product (Recreational only)	Standard Limited Warranty	Standard Limited Corrosion Warranty	Commercial Application
Verado 400R	1 year	3 years	None

## Outside of Asia

For product purchased outside of the Asian region, contact the distributor in your country, or the Marine Power Service Center closest to you.

## EUROPE AND THE CONFEDERATION OF INDEPENDENT STATES (CIS) WARRANTY CHARTS—OUTBOARD AND JET

Product (Recreational only)	Standard Limited Warranty	Standard Limited Corrosion Warranty	Commercial Application
2-Stroke	2 years	3 years	Contact the Marine Power Service Center closest to you
FourStroke	2 years	3 years	
OptiMax (including Pro XS)	3 years	3 years	
Verado (including Pro)	3 years	3 years	

# WARRANTY INFORMATION

Racing Product (Recreational only)	Standard Limited Warranty	Standard Limited Corrosion Warranty	Commercial Application
Verado 400R	2 years	3 years	Contact the Marine Power Service Center closest to you

## Outside Europe and CIS

For products purchased outside of Europe and CIS regions, contact the distributor in your country, or the Marine Power Service Center closest to you.

## MIDDLE-EAST AND AFRICA (EXCLUDING SOUTH AFRICA) WARRANTY CHARTS—OUTBOARD AND JET

Product (Recreational only)	Standard Limited Warranty	Standard Limited Corrosion Warranty	Commercial Application
2-Stroke	1 year	3 years	Contact the Marine Power Service Center closest to you
FourStroke	2 years	3 years	
OptiMax (including Pro XS)	3 years	3 years	
Verado (including Pro)	3 years	3 years	

Racing Product (Recreational only)	Standard Limited Warranty	Standard Limited Corrosion Warranty
Verado 400R	2 years	3 years

## Outside Middle-East and Africa

For products purchased outside of the Middle-East and Africa regions, contact the distributor in your country, or the Marine Power Service Center closest to you.

# WARRANTY INFORMATION

## SOUTH AFRICA WARRANTY CHARTS—OUTBOARD AND JET

Product (Recreational only)	Standard Limited Warranty	Standard Limited Corrosion Warranty	Commercial Application
2-Stroke	2 years	3 years	Contact the Marine Power Service Center closest to you
FourStroke	2 years	3 years	
OptiMax (including Pro XS)	3 years	3 years	
Verado (including Pro)	3 years	3 years	

Racing Product (Recreational only)	Standard Limited Warranty	Standard Limited Corrosion Warranty
Verado 400R	2 years	3 years

### Outside South Africa

For products purchased outside of the South Africa region, contact the distributor in your country, or the Marine Power Service Center closest to you.

# GENERAL INFORMATION

## Boater's Responsibilities

The operator (driver) is responsible for the correct and safe operation of the boat and the safety of its occupants and general public. It is strongly recommended that each operator read and understand this entire manual before operating the outboard.

Be sure that at least one additional person onboard is instructed in the basics of starting and operating the outboard and boat handling in case the driver is unable to operate the boat.

## Before Operating Your Outboard

Read this manual carefully. Learn how to operate your outboard properly. If you have any questions, contact your dealer.

Safety and operating information that is practiced, along with using good common sense, can help prevent personal injury and product damage.

This manual as well as safety labels posted on the outboard use the following safety alerts to draw your attention to special safety instructions that should be followed.

### WARNING

Indicates a hazardous situation which, if not avoided, could result in death or serious injury.

### CAUTION

Indicates a hazardous situation which, if not avoided, could result in minor or moderate injury.

### NOTICE

Indicates a situation which, if not avoided, could result in engine or major component failure.

## Boat Horsepower Capacity

### WARNING

Exceeding the boat's maximum horsepower rating can cause serious injury or death. Overpowering the boat can affect boat control and flotation characteristics or break the transom. Do not install an engine that exceeds the boat's maximum power rating.

# GENERAL INFORMATION

Do not overpower or overload your boat. Most boats will carry a required capacity plate indicating the maximum acceptable power and load as determined by the manufacturer following certain federal guidelines. If in doubt, contact your dealer or the boat manufacturer.

U.S. COAST GUARD CAPACITY	
MAXIMUM HORSEPOWER	XXX
MAXIMUM PERSON CAPACITY (POUNDS)	XXX
MAXIMUM WEIGHT CAPACITY	XXX

26777

## High-Speed and High-Performance Boat Operation

If your outboard is to be used on a high-speed or high-performance boat with which you are unfamiliar, we recommend that you do not operate it at its high speed capability without first requesting an initial orientation and familiarization demonstration ride with your dealer or an operator experienced with your boat/outboard combination. For additional information, obtain a copy of our **Hi-Performance Boat Operation** booklet from your dealer, distributor, or Mercury Marine.

## Outboard Remote Control Models

The outboard must be equipped with a Mercury remote control designed for digital throttle and shift. Start-in-gear protection is provided by the remote control system.

## Lanyard Stop Switch

The purpose of a lanyard stop switch is to turn off the engine when the operator moves far enough away from the operator's position (as in accidental ejection from the operator's position) to activate the switch. Tiller handle outboards and some remote control units are equipped with a lanyard stop switch. A lanyard stop switch can be installed as an accessory - generally on the dashboard or side adjacent to the operator's position.

A decal near the lanyard stop switch is a visual reminder for the operator to attach the lanyard to their personal flotation device (PFD) or wrist.

# GENERAL INFORMATION

The lanyard cord is usually 122–152 cm (4–5 feet) in length when stretched out, with an element on one end made to be inserted into the switch and a clip on the other end for attaching to the operator's PFD or wrist. The lanyard is coiled to make its at-rest condition as short as possible to minimize the likelihood of lanyard entanglement with nearby objects. Its stretched-out length is made to minimize the likelihood of accidental activation should the operator choose to move around in an area close to the normal operator's position. If it is desired to have a shorter lanyard, wrap the lanyard around the operator's wrist or leg, or tie a knot in the lanyard.

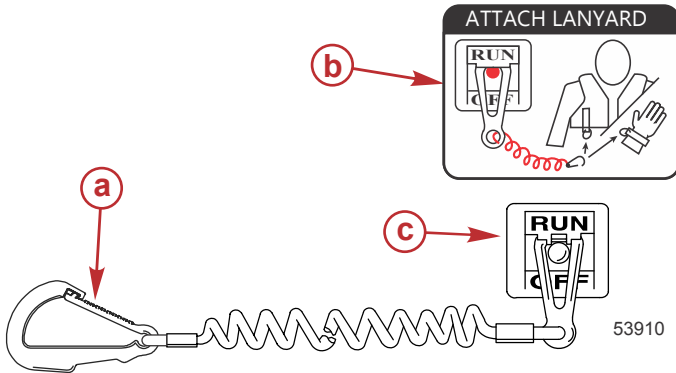

- a - Lanyard cord clip
- b - Lanyard decal
- c - Lanyard stop switch

Read the following Safety Information before proceeding.

**Important Safety Information:** The purpose of a lanyard stop switch is to stop the engine when the operator moves far enough away from the operator's position to activate the switch. This would occur if the operator accidentally falls overboard or moves within the boat a sufficient distance from the operator's position. Falling overboard and accidental ejections are more likely to occur in certain types of boats such as low sided inflatables, bass boats, high performance boats, and light, sensitive handling fishing boats operated by a hand tiller. Falling overboard and accidental ejections are also likely to occur as a result of poor operating practices such as sitting on the back of the seat or gunwale at planing speeds, standing at planing speeds, sitting on elevated fishing boat decks, operating at planing speeds in shallow or obstacle infested waters, releasing your grip on a steering wheel or tiller handle that is pulling in one direction, drinking alcohol or consuming drugs, or daring high speed boat maneuvers.



# GENERAL INFORMATION

While activation of the lanyard stop switch will stop the engine immediately, a boat will continue to coast for some distance depending upon the velocity and degree of any turn at shut down. However, the boat will not complete a full circle. While the boat is coasting, it can cause injury to anyone in the boat's path as seriously as the boat would when under power.

We strongly recommend that other occupants be instructed on proper starting and operating procedures should they be required to operate the engine in an emergency (if the operator is accidentally ejected).

## **⚠ WARNING**

**If the operator falls out of the boat, stop the engine immediately to reduce the possibility of serious injury or death from being struck by the boat. Always properly connect the operator to the stop switch using a lanyard.**

## **⚠ WARNING**

**Avoid serious injury or death from deceleration forces resulting from accidental or unintended stop switch activation. The boat operator should never leave the operator's station without first disconnecting the stop switch lanyard from the operator.**

Accidental or unintended activation of the switch during normal operation is also a possibility. This could cause any, or all, of the following potentially hazardous situations:

- Occupants could be thrown forward due to unexpected loss of forward motion - a particular concern for passengers in the front of the boat who could be ejected over the bow and possibly struck by the gearcase or propeller.
- Loss of power and directional control in heavy seas, strong current, or high winds.
- Loss of control when docking.

## **KEEP THE LANYARD STOP SWITCH AND LANYARD CORD IN GOOD OPERATING CONDITION**

Before each use, check to ensure the lanyard stop switch works properly. Start the engine and stop it by pulling the lanyard cord. If the engine does not stop, have the switch repaired before operating the boat.

Before each use, visually inspect the lanyard cord to ensure it is in good working condition and that there are no breaks, cuts, or wear to the cord. Check that the clips on the ends of the cord are in good condition. Replace any damaged or worn lanyard cords.

# GENERAL INFORMATION

## Protecting People in the Water

### WHILE YOU ARE CRUISING

It is very difficult for a person standing or floating in the water to take quick action to avoid a boat heading in his/her direction, even at slow speed.



Always slow down and exercise extreme caution any time you are boating in an area where there might be people in the water.

Whenever a boat is moving (coasting) and the outboard gear shift is in neutral position, there is sufficient force by the water on the propeller to cause the propeller to rotate. This neutral propeller rotation can cause serious injury.

### WHILE THE BOAT IS STATIONARY

#### **▲ WARNING**

**A spinning propeller, a moving boat, or any solid device attached to the boat can cause serious injury or death to swimmers. Stop the engine immediately whenever anyone in the water is near your boat.**

Shift the outboard into neutral and shut off the engine before allowing people to swim or be in the water near your boat.

## Exhaust Emissions

### BE ALERT TO CARBON MONOXIDE POISONING

Carbon monoxide (CO) is a deadly gas that is present in the exhaust fumes of all internal combustion engines, including the engines that propel boats, and the generators that power boat accessories. By itself, CO is odorless, colorless, and tasteless, but if you can smell or taste engine exhaust, you are inhaling CO.

Early symptoms of carbon monoxide poisoning, which are similar to the symptoms of seasickness and intoxication, include headache, dizziness, drowsiness, and nausea.

# GENERAL INFORMATION

## ⚠ WARNING

Inhaling engine exhaust gases can result in carbon monoxide poisoning, which can lead to unconsciousness, brain damage, or death. Avoid exposure to carbon monoxide.

Stay clear from exhaust areas when engine is running. Keep the boat well-ventilated while at rest or underway.

## STAY CLEAR OF EXHAUST AREAS

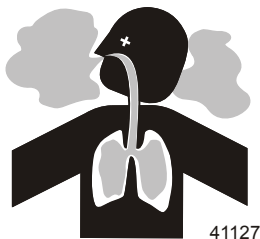

Engine exhaust gases contain harmful carbon monoxide. Avoid areas of concentrated engine exhaust gases. When engines are running, keep swimmers away from the boat, and do not sit, lie, or stand on swim platforms or boarding ladders. While underway, do not allow passengers to be positioned immediately behind the boat (platform dragging, teak/body surfing). This dangerous practice not only places a person in an area of high engine exhaust concentration, but also subjects them to the possibility of injury from the boat propeller.

## GOOD VENTILATION

Ventilate the passenger area, open side curtains or forward hatches to remove fumes.

Example of desired air flow through the boat:

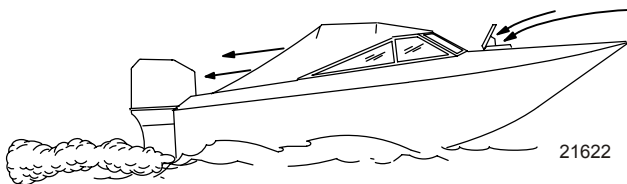

## POOR VENTILATION

Under certain running and/or wind conditions, permanently enclosed or canvas enclosed cabins or cockpits with insufficient ventilation may draw in carbon monoxide. Install one or more carbon monoxide detectors in your boat.

Although the occurrence is rare, on a very calm day, swimmers and passengers in an open area of a stationary boat that contains, or is near, a running engine may be exposed to a hazardous level of carbon monoxide.

# GENERAL INFORMATION

## 1. Examples of poor ventilation while the boat is stationary:

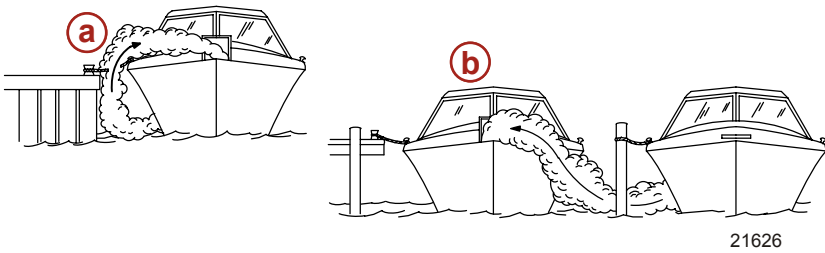

- a** - Operating the engine when the boat is moored in a confined space
- b** - Mooring close to another boat that has its engine operating

## 2. Examples of poor ventilation while the boat is moving:



- a** - Operating the boat with the trim angle of the bow too high
- b** - Operating the boat with no forward hatches open (station wagon effect)

## Passenger Safety Message - Pontoon Boats and Deck Boats

Whenever the boat is in motion, observe the location of all passengers. Do not allow any passengers to stand or use seats other than those designated for traveling faster than idle speed. A sudden reduction in boat speed, such as plunging into a large wave or wake, a sudden throttle reduction, or a sharp change of boat direction, could throw them over the front of the boat. Falling over the front of the boat between the two pontoons will position them to be run over by the outboard.

## BOATS HAVING AN OPEN FRONT DECK

No one should ever be on the deck in front of the fence while the boat is in motion. Keep all passengers behind the front fence or enclosure.

# GENERAL INFORMATION

Persons on the front deck could easily be thrown overboard or persons dangling their feet over the front edge could get their legs caught by a wave and pulled into the water.

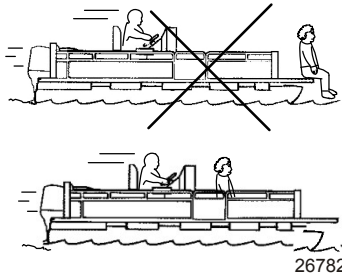

## ⚠ WARNING

**Sitting or standing in an area of the boat not designed for passengers at speeds above idle can cause serious injury or death. Stay back from the front end of deck boats or raised platforms and remain seated while the boat is in motion.**

### BOATS WITH FRONT MOUNTED, RAISED PEDESTAL FISHING SEATS

Elevated fishing seats are not intended for use when the boat is traveling faster than idle or trolling speed. Sit only in seats designated for traveling at faster speeds.

Any unexpected, sudden reduction in boat speed could result in the elevated passenger falling over the front of the boat.

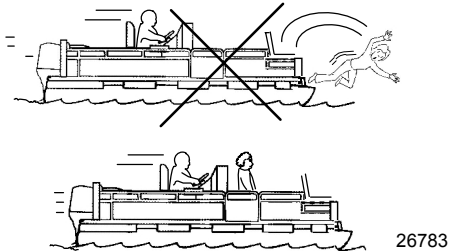

# GENERAL INFORMATION

## Wave and Wake Jumping

Operating recreational boats over waves and wake is a natural part of boating. However, when this activity is done with sufficient speed to force the boat hull partially or completely out of the water, certain hazards arise, particularly when the boat enters the water.

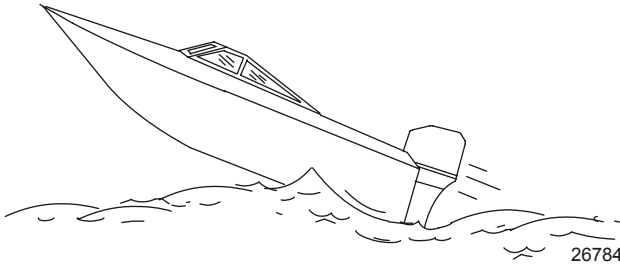

The primary concern is the boat changing direction while in the midst of the jump. In such case, the landing may cause the boat to veer violently in a new direction. Such a sharp change in direction can cause occupants to be thrown out of their seats, or out of the boat.

### **⚠ WARNING**

**Wave or wake jumping can cause serious injury or death from occupants being thrown within or out of the boat. Avoid wave or wake jumping whenever possible.**

There is another less common hazardous result from allowing your boat to launch off a wave or wake. If the bow of your boat pitches down far enough while airborne, upon water contact it may penetrate under the water surface and submarine for an instant. This will bring the boat to a nearly instantaneous stop and can send the occupants flying forward. The boat may also steer sharply to one side.

# GENERAL INFORMATION

## Impact with Underwater Hazards

Reduce speed and proceed with caution whenever you drive a boat in shallow water areas, or in areas where you suspect underwater obstacles may exist which could be struck by the outboard or the boat bottom. **The most important thing you can do to help reduce injury or impact damage from striking a floating or underwater object is to control the boat speed. Under these conditions, boat speed should be kept to a minimum planing speed of 24 to 40 km/h (15 to 25 mph).**

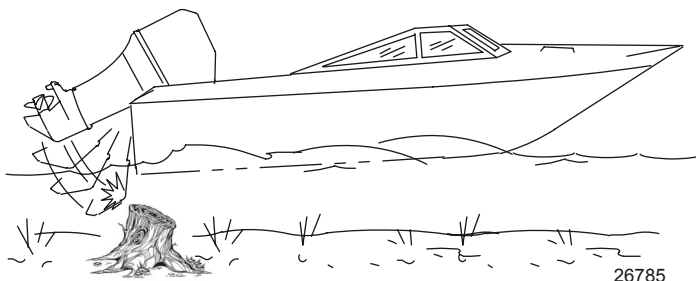

Striking a floating or underwater object could result in an infinite number of situations. Some of these situations could result in the following:

- Part of the outboard or the entire outboard could break loose and fly into the boat.
- The boat could move suddenly in a new direction. Such a sharp change in direction can cause occupants to be thrown out of their seats or out of the boat.
- A rapid reduction in speed. This will cause occupants to be thrown forward, or even out of the boat.
- Impact damage to the outboard and/or boat.

Keep in mind, the most important thing you can do to help reduce injury or impact damage during an impact is control the boat speed. Boat speed should be kept to a minimum planing speed when driving in waters known to have underwater obstacles.

After striking a submerged object, stop the engine as soon as possible and inspect it for any broken or loose parts. If damage is present or suspected, the outboard should be taken to an authorized dealer for a thorough inspection and necessary repair.

The boat should also be checked for any hull fractures, transom fractures, or water leaks.

Operating a damaged outboard could cause additional damage to other parts of the outboard, or could affect control of the boat. If continued running is necessary, do so at greatly reduced speeds.

# GENERAL INFORMATION

## WARNING

Operating a boat or engine with impact damage can result in product damage, serious injury, or death. If the vessel experiences any form of impact, have an authorized Mercury Marine dealer inspect and repair the vessel or power package.

## Selecting Accessories for Your Outboard

Genuine Mercury Precision or Quicksilver Accessories have been specifically designed and tested for your outboard. These accessories are available from Mercury Marine dealers.

**IMPORTANT: Check with your dealer before installing accessories. The misuse of approved accessories or the use of nonapproved accessories can damage the product.**

Some accessories not manufactured or sold by Mercury Marine are not designed to be safely used with your outboard or outboard operating system. Read the installation, operation and maintenance manuals for all your selected accessories.

Refer to **Outboard Installation - Accessories Mounted to the Transom Clamp Bracket** for important information on mounting accessories to the transom clamp bracket.

## Safe Boating Recommendations

To safely enjoy the waterways, familiarize yourself with local and all other governmental boating regulations and restrictions and consider the following suggestions.

**Know and obey all nautical rules and laws of the waterways.**

- We recommend that all powerboat operators complete a boating safety course. In the U.S., the U.S. Coast Guard Auxiliary, the Power Squadron, the Red Cross, and your state or provincial boating law enforcement agency provide courses. For more information in the U.S., call the Boat U.S. Foundation at 1-800-336-BOAT (2628).

**Perform safety checks and required maintenance.**

- Follow a regular schedule and ensure that all repairs are properly made.

**Check safety equipment onboard.**

- Here are some suggestions of the types of safety equipment to carry when boating:
  - Approved fire extinguishers
  - Signal devices: flashlight, rockets or flares, flag, and whistle or horn
  - Tools necessary for minor repairs
  - Anchor and extra anchor line
  - Manual bilge pump and extra drain plugs



# GENERAL INFORMATION

- Drinking water
- Radio
- Paddle or oar
- Spare propeller, thrust hubs, and an appropriate wrench
- First aid kit and instructions
- Waterproof storage containers
- Spare operating equipment, batteries, bulbs, and fuses
- Compass and map or chart of the area
- Personal flotation device (one per person onboard)

**Watch for signs of weather change and avoid foul weather and rough-sea boating.**

**Tell someone where you are going and when you expect to return.**

**Passenger boarding.**

- Stop the engine whenever passengers are boarding, unloading, or are near the back (stern) of the boat. Shifting the drive unit into neutral is not sufficient.

**Use personal flotation devices.**

- Federal law requires that there be a U.S. Coast Guard-approved life jacket (personal flotation device), correctly sized and readily accessible for every person onboard, plus a throwable cushion or ring. We strongly advise that everyone wear a life jacket at all times while in the boat.

**Prepare other boat operators.**

- Instruct at least one person onboard in the basics of starting and operating the engine and boat handling in case the driver becomes disabled or falls overboard.

**Do not overload your boat.**

- Most boats are rated and certified for maximum load (weight) capacities (refer to your boat's capacity plate). Know your boat's operating and loading limitations. Know if your boat will float if it is full of water. When in doubt, contact your authorized Mercury Marine dealer or the boat manufacturer.

**Ensure that everyone in the boat is properly seated.**

- Do not allow anyone to sit or ride on any part of the boat that was not intended for such use. This includes the backs of seats, gunwales, transom, bow, decks, raised fishing seats, and any rotating fishing seat. Passengers should not sit or ride anywhere that sudden unexpected acceleration, sudden stopping, unexpected loss of boat control, or sudden boat movement could cause a person to be thrown overboard or into the boat. Ensure that all passengers have a proper seat and are in it before any boat movement.

# GENERAL INFORMATION

**Never operate a boat while under the influence of alcohol or drugs. It is the law.**

- Alcohol or drugs can impair your judgment and greatly reduce your ability to react quickly.

**Know your boating area and avoid hazardous locations.**

**Be alert.**

- The operator of the boat is responsible by law to maintain a proper lookout by sight and hearing. The operator must have an unobstructed view particularly to the front. No passengers, load, or fishing seats should block the operator's view when the boat is above idle or planing transition speed. Watch out for others, the water, and your wake.

**Never drive your boat directly behind a water skier.**

- Your boat traveling at 40 km/h (25 mph) will overtake a fallen skier who is 61 m (200 ft) in front of you in five seconds.

**Watch fallen skiers.**

- When using your boat for waterskiing or similar activities, always keep a fallen or down skier on the operator's side of the boat while returning to attend to the skier. The operator should always have the down skier in sight and never back up to the skier or anyone in the water.

**Report accidents.**

- Boat operators are required by law to file a boating accident report with their state boating law enforcement agency when their boat is involved in certain boating accidents. A boating accident must be reported if 1) there is loss of life or probable loss of life, 2) there is personal injury requiring medical treatment beyond first aid, 3) there is damage to boats or other property where the damage value exceeds \$500.00, or 4) there is complete loss of the boat. Seek further assistance from local law enforcement.

# GENERAL INFORMATION

## Specifications

Models	200 Pro	225	250	250 Pro
Horsepower	200	225	250	250
Kilowatts	149	165	184	184
Full throttle RPM range	5800–6400			
Idle RPM in neutral gear*	550			
Number of cylinders	6			
Displacement	2,598 cc (158.5 cid)			
Cylinder bore	82 mm (3.23 in.)			
Stroke	82 mm (3.23 in.)			
Spark plug	NGK ILFR6G-E			
Spark plug gap	0.8 mm (0.0315 in.)			
Spark plug hex size	16 mm			
Gear ratio 1 inch shaft	1.85:1			
Recommended gasoline	Refer to <b>Fuel and Oil</b>			
Recommended oil	Refer to <b>Fuel and Oil</b>			
Gearcase capacity	Refer to <b>Maintenance - Gearcase Lubrication</b>			
Engine oil capacity with oil filter replacement	7.0 Liter (7.4 US qt)			
Required battery type	12-volt AGM (absorbed glass mat) battery			
USA (SAE) battery type	800 minimum marine cranking amps (MCA) with a minimum reserve capacity of 135 minutes RC25 rating			
International (EN) battery type	975 minimum cold cranking amps (CCA) with a minimum of 65 amp hours (Ah)			

\* Engine at normal operation temperature.

Models	300	300 Pro	350	350 Pro
Horsepower	300	300	350	350

# GENERAL INFORMATION

<b>Models</b>		<b>300</b>	<b>300 Pro</b>	<b>350</b>	<b>350 Pro</b>
Kilowatts		221	221	261	261
Full throttle RPM range		5800–6400			
Idle RPM in neutral gear*		550		600	
Number of cylinders		6			
Displacement		2,598 cc (158.5 cid)			
Cylinder bore		82 mm (3.23 in.)			
Stroke		82 mm (3.23 in.)			
Spark plug		NGK ILFR6G-E			
Spark plug gap		0.8 mm (0.0315 in.)			
Spark plug hex size		16 mm			
Gear Ratio	1 inch shaft	1.85:1	1.75:1		
	1.25 inch shaft	1.75:1		1.75:1	1.75:1
Recommended gasoline		Refer to <b>Fuel and Oil</b>			
Recommended oil		Refer to <b>Fuel and Oil</b>			
Gearcase capacity		Refer to <b>Maintenance - Gearcase Lubrication</b>			
Engine oil capacity with oil filter replacement		7.0 Liter (7.4 US qt)			
Required battery type		12-volt AGM (absorbed glass mat) battery			
USA (SAE) battery type		800 minimum marine cranking amps (MCA) with a minimum reserve capacity of 135 minutes RC25 rating			
International (EN) battery type		975 minimum cold cranking amps (CCA) with a minimum of 65 amp hours (Ah)			

\* Engine at normal operation temperature.

# GENERAL INFORMATION

## Recording Serial Number

It is important to record this number for future reference. The serial number is located on the outboard as shown.

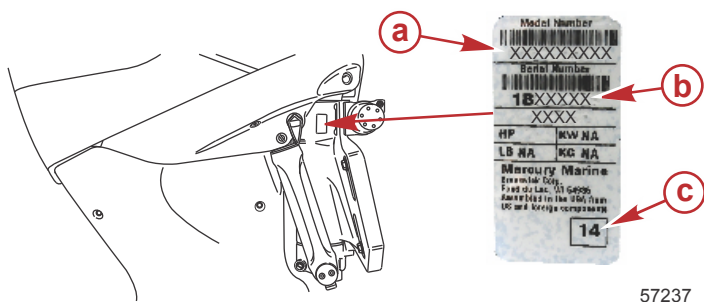

- a** - Model number
- b** - Serial number
- c** - Year manufactured

## Component Identification 200–300

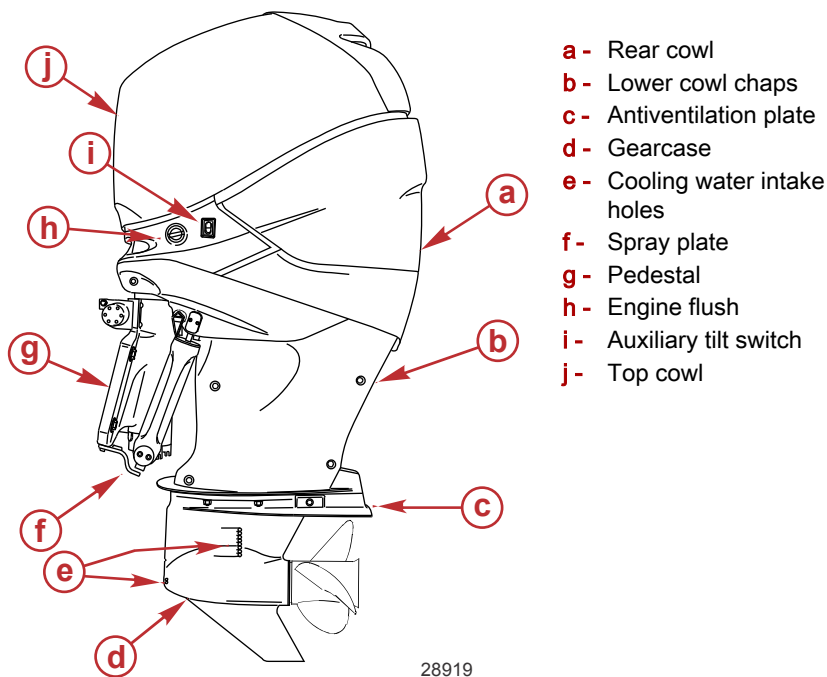

# GENERAL INFORMATION

## 350 HP Component Identification

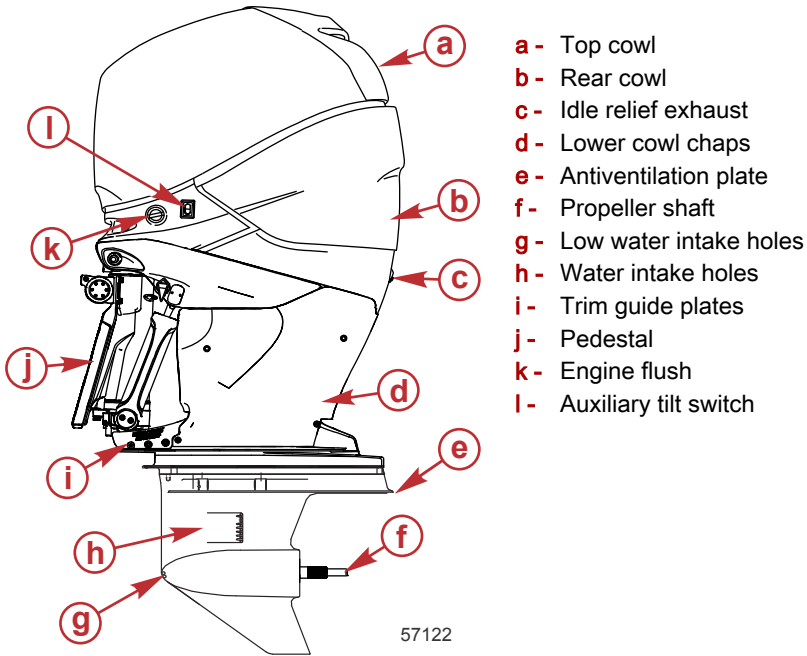

## Propeller Selection

The propeller on your outboard is one of the most important components in the propulsion system. An improper propeller choice can significantly affect the performance of your boat and could result in damage to the outboard engine.

When choosing a propeller, a full selection of aluminum and stainless steel propellers specifically designed for your outboard are available through Mercury Marine. To view the entire product offering and find the correct propeller that is best suited for your application, visit [www.mercurmarinepropellers.com](http://www.mercurmarinepropellers.com) or see your local authorized Mercury dealer.

## SELECTING THE CORRECT PROPELLER

An accurate tachometer for measuring engine speed is important in choosing the correct propeller.

# GENERAL INFORMATION

Choose a propeller for your boating application that will allow the engine to operate within the specified full throttle operating range. When operating the boat at full throttle under normal load conditions, the engine RPM should be in the upper half of the recommended full throttle RPM range. Refer to **Specifications**. If engine RPM is above that range, select a propeller of increased pitch in order to reduce engine RPM. If engine RPM is below the recommended range, select a propeller of reduced pitch to increase engine RPM.

**IMPORTANT: To ensure proper fit, and performance, Mercury Marine recommends the use of Mercury or Quicksilver branded propellers and mounting hardware.**

Propellers are designated by the diameter, pitch, number of blades, and material. The diameter and pitch are stamped (cast) into the side or the end of the propeller hub. The first number represents the diameter of the propeller and the second number represents the pitch. For example, 14x19 represents a propeller with a 14 inch diameter and 19 inches of pitch.

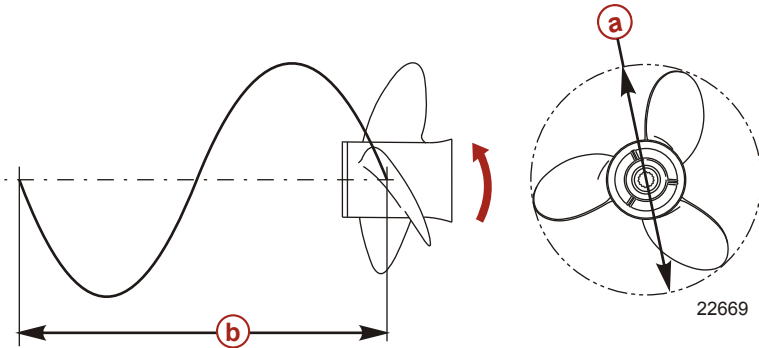

- a** - Diameter
- b** - Pitch - Travel during one revolution

The following are some propeller basics that will help you determine the correct propeller for your boating application.

**Diameter** - The diameter is the distance across the imaginary circle that is made when the propeller rotates. The correct diameter for each propeller has been predetermined for the design of your outboard. However, when more than one diameter is available for the same pitch, use a larger diameter for heavy boat applications and a smaller diameter for lighter applications.

**Pitch** - The pitch is the theoretical distance, in inches, that a propeller travels forward during one revolution. Pitch can be thought of similar to gears in a car. The lower the gear, the faster the car will accelerate, but with lower overall top speed. Likewise, a lower pitch propeller will accelerate quickly, but top-end speed will be reduced. The higher the propeller pitch the faster the boat will usually go; though typically slowing acceleration.

# GENERAL INFORMATION

**Determining the correct pitch size** - First, check the full throttle RPM under normal load condition. If the full throttle RPM is within the recommended range, select a replacement or upgrade propeller with the same pitch as the current propeller.

- Adding 1 inch of pitch will reduce the full throttle RPM by 150 to 200
- Subtracting 1 inch of pitch will increase full throttle RPM by 150 to 200
- Upgrading from a 3-blade propeller to a 4-blade propeller will generally decrease full throttle RPM by 50 to 100

**IMPORTANT: Avoid damage to the engine. Never use a propeller that allows the engine to exceed the recommended full throttle RPM range when under normal full throttle operation.**

## PROPELLER MATERIAL

Most propellers manufactured by Mercury Marine are made from either aluminum or stainless steel. Aluminum is suitable for general purpose use and is standard equipment on many new boats. Stainless steel is over five times more durable than aluminum and typically provides performance gains in acceleration and top end speed due to design efficiencies. Stainless steel propellers also come in a larger variety of sizes and styles that allow you to dial in the ultimate performance for your boat.

## 3 BLADE VS. 4 BLADE

Available in many sizes of both aluminum and stainless, 3 and 4-blade propellers have unique performance characteristics. In general, 3-blade propellers offer good all around performance and higher top speed than 4-blade propellers. However, 4-blade propellers are usually faster to plane and more efficient at cruising speeds, but lack the top end speed of a 3-blade propeller.



# TRANSPORTING

## Trailing Boat/Outboard

When transporting the boat on a trailer, the outboard should be positioned and supported in one of the following ways:

1. If the boat trailer provides sufficient ground clearance, the outboard may be tilted down to the vertical operating position with no additional support required.

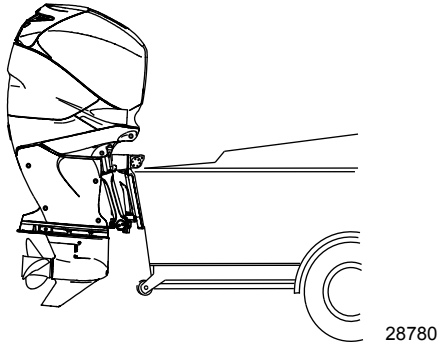

2. If additional ground clearance is required, the outboard should be tilted up and supported using the outboard's tilt support bracket (trailing position) in addition to using an accessory transom support device. Refer to **Features and Controls - Power Trim and Tilt**.

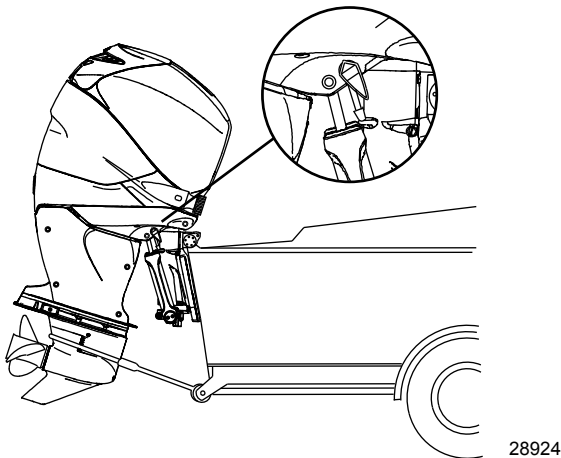

# TRANSPORTING

3. For maximum ground clearance, the outboard can be tilted to the full tilt position and supported using the outboard tilt support bracket or an accessory transom support device.

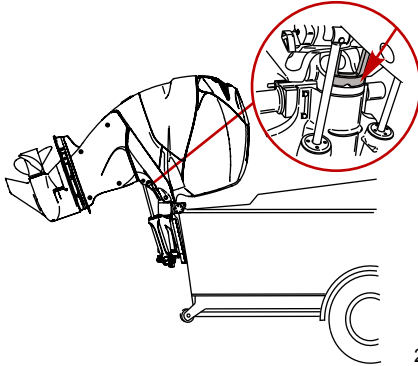

28779

Additional clearance may be required for railroad crossings, driveways, and trailer bouncing. See your local dealer for recommendations.

**IMPORTANT: Do not rely on the power trim/tilt system to maintain proper ground clearance for trailering. The power trim/tilt system is not intended to support the outboard for trailering.**

# FUEL AND OIL

## Fuel Recommendations

**IMPORTANT: Use of improper gasoline can damage your engine. Engine damage resulting from the use of improper gasoline is considered misuse of the engine, and damage caused thereby will not be covered under the limited warranty.**

Mercury Marine engines will operate satisfactorily when using a major brand of unleaded gasoline meeting the following specifications:

### MODELS 350, 350 PRO, 400R

**USA and Canada** - Having a posted pump Octane Rating of 91 (R+M)/2 Octane is required for best performance. Having a posted pump Octane Rating of 89 (R+M)/2 minimum is acceptable, however, performance losses may occur. Do not use leaded gasoline.

**Outside USA and Canada** - Having a posted pump Octane Rating of 95 RON is required for best performance. Having a posted pump Octane Rating of 93 RON minimum is acceptable, however, performance losses may occur. If unleaded gasoline is not available, use a major brand of leaded gasoline.

### MODELS 250 PRO, 300 PRO, 300

**USA and Canada** - Having a posted pump Octane Rating of 91 (R+M)/2 Octane is required for best performance. Having a posted pump Octane Rating of 87 (R+M)/2 minimum is acceptable, however, performance losses may occur. Do not use leaded gasoline.

**Outside USA and Canada** - Having a posted pump Octane Rating of 95 RON is required for best performance. Having a posted pump Octane Rating of 91 RON minimum is acceptable, however, performance losses may occur. If unleaded gasoline is not available, use a major brand of leaded gasoline.

### MODELS 200 PRO, 225 AND 250

**USA and Canada** - Having a posted pump Octane Rating of 87 (R+M)/2 is acceptable. Premium gasoline is also acceptable. Do not use leaded gasoline.

**Outside USA and Canada** - Having a posted pump Octane Rating of 91 RON is acceptable. Premium gasoline is also acceptable. If unleaded gasoline is not available, use a major brand of leaded gasoline.

## USING REFORMULATED (OXYGENATED) GASOLINES (USA ONLY)

This type of gasoline is required in certain areas of the USA. The two types of oxygenates used in these fuels are alcohol (ethanol) or ether (MTBE or ETBE). If ethanol is the oxygenate that is used in the gasoline in your area, refer to **Gasolines Containing Alcohol**.

These reformulated gasolines are acceptable for use in your Mercury Marine engine.

## GASOLINES CONTAINING ALCOHOL

**IMPORTANT: Do not use fuels that contain more than 10% alcohol. E15 and E85 fuels should not be used with this engine.**

# FUEL AND OIL

If the gasoline in your area contains either methanol (methyl alcohol) or ethanol (ethyl alcohol), you should be aware of certain adverse effects that can occur. These adverse effects are more severe with methanol. Increasing the percentage of alcohol in the fuel can also worsen these adverse effects.

Some of these adverse effects are caused because the alcohol in the gasoline can absorb moisture from the air, resulting in a separation of the water/alcohol from the gasoline in the fuel tank.

The fuel system components on your Mercury Marine engine will withstand up to 10% alcohol content in the gasoline. We do not know what percentage your boat's fuel system will withstand. Contact your boat manufacturer for specific recommendations on the boat's fuel system components (fuel tanks, fuel lines, and fittings). Be aware that gasolines containing alcohol may cause increased:

- Corrosion of metal parts
- Deterioration of rubber or plastic parts
- Fuel permeation through rubber fuel lines
- Starting and operating difficulties

## WARNING

**Fuel leakage is a fire or explosion hazard, which can cause serious injury or death. Periodically inspect all fuel system components for leaks, softening, hardening, swelling, or corrosion, particularly after storage. Any sign of leakage or deterioration requires replacement before further engine operation.**

Because of possible adverse effects of alcohol in gasoline, it is recommended that only alcohol-free gasoline be used where possible. If only fuel containing alcohol is available, or if the presence of alcohol is unknown, increased inspection frequency for leaks and abnormalities is required.

**IMPORTANT: When operating a Mercury Marine engine on gasoline containing alcohol, storage of gasoline in the fuel tank for long periods should be avoided. Long periods of storage, common to boats, create unique problems. In cars, alcohol-blend fuels normally are consumed before they can absorb enough moisture to cause trouble, but boats often sit idle long enough for phase separation to take place. In addition, internal corrosion may take place during storage if alcohol has washed protective oil films from internal components.**

## Fuel Additives

To minimize carbon deposit buildup in the engine, add Mercury or Quicksilver Quickleen Engine and Fuel System Cleaner to the engine's fuel at each tank throughout the boating season. Use the additive as directed on the container.

## Low Permeation Fuel Hose Requirement

Required for outboards manufactured for sale, sold, or offered for sale in the United States.

# FUEL AND OIL

- The Environmental Protection Agency (EPA) requires that any outboard manufactured after January 1, 2009, must use low permeation fuel hose for the primary fuel hose connecting the fuel tank to the outboard.
- Low permeation hose is USCG Type B1-15 or Type A1-15, defined as not exceeding 15/gm<sup>2</sup>/24 h with CE 10 fuel at 23 °C as specified in SAE J 1527 - marine fuel hose.

## Fuel Demand Valve

Some boat fuel systems incorporate a fuel demand valve between the fuel tank and the engine and others do not. This engine can be operated with or without a fuel demand valve.

The fuel demand valve has a manual release. The manual release can be used (pushed in) to open (bypass) the valve in case of a fuel blockage in the valve.

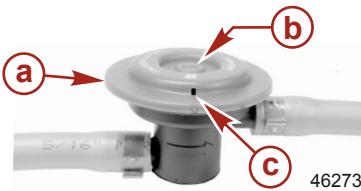

- a** - Fuel demand valve - installed in the fuel hose between the fuel tank and primer bulb
- b** - Manual release
- c** - Vent/water drain holes

## Engine Oil Recommendations

### 200–350 HP MODELS

Mercury 25W-40 NMMA certified FC-W Catalyst Compatible® Synthetic Blend Marine Engine Oil is the preferred choice for general, all-temperature use in all 200–350 HP Verado engines.

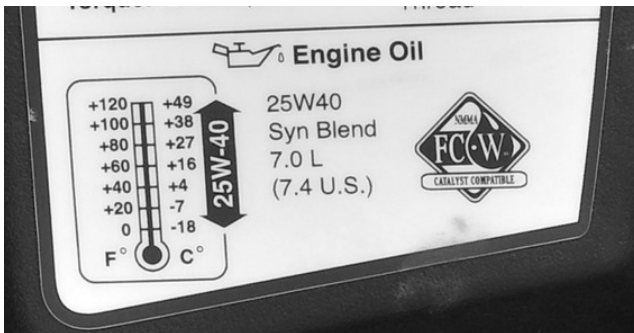

In lieu of the preferred grade oil, the following may be used (listed in the order of preference):

- Mercury 25W40 Mineral Catalyst Compatible FC-W® Oil
- 25W-40 NMMA certified FC-W® Marine Engine Oil

# FUEL AND OIL

## Checking and Adding Engine Oil

**IMPORTANT:** Do not overfill. Tilt the outboard out/up past vertical for approximately one minute to allow trapped oil to drain back to the oil sump. The outboard must be in a vertical (not tilted) position when checking engine oil. For accurate readings, check oil only when engine is cold or after engine has not run for at least an hour.

1. Before starting (cold engine) tilt outboard out/up past vertical to allow trapped oil to drain back to the oil sump. Allow outboard to remain tilted for approximately one minute.
2. Tilt the outboard to a vertical operating position.
3. Remove the top cowl. Refer to **Maintenance - Cowl Removal and Installation**.
4. Pull out the dipstick. Wipe the dipstick end with a clean rag or towel and push it back in all the way.
5. Pull the dipstick back out again and observe the oil level. Oil should be in the operating range (crosshatched region).

**IMPORTANT:** Do not try to fill the oil level to the top of the operating range (crosshatched region). Oil level is correct as long as it appears in the operating range (crosshatched region).

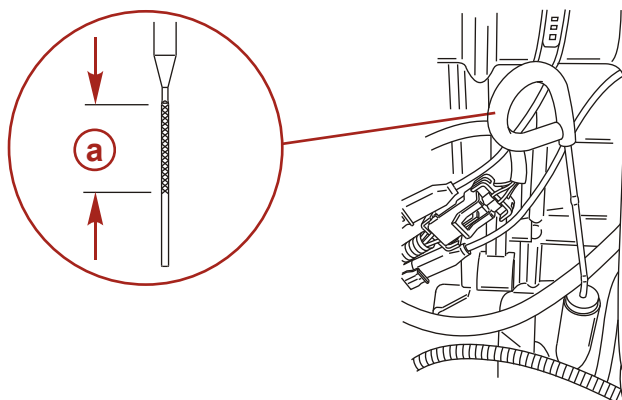

15730

**a** - Oil level operating range

## FUEL AND OIL

6. If the oil level is below the operating range (crosshatched region), remove the oil filler cap and add approximately 500 ml (16 oz) of specified outboard motor oil.

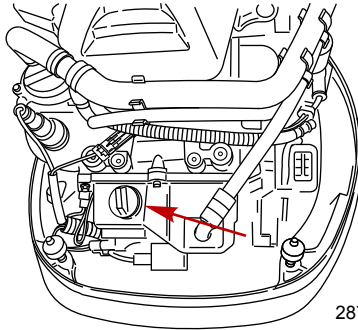

7. Tilt outboard out/up past vertical to allow trapped oil to drain back to the oil sump. Allow outboard to remain tilted for approximately one minute.
8. Tilt the outboard to a vertical operating position and check the dipstick.
9. Repeat the process until oil level is on the operating range (crosshatched region). Do not try to fill to the upper end of the operating range (crosshatched region).

**IMPORTANT: Inspect oil for signs of contamination. Oil contaminated with water will have a milky color to it; oil contaminated with fuel will have a strong fuel smell. If contaminated oil is noticed, have the engine checked by your dealer.**

10. Push the dipstick back in all the way.
11. Install the oil fill cap hand tight.
12. Install the top cowl.

# FEATURES AND CONTROLS

## Panel Mount Control Features and Operation

1. Operation of the shift and throttle is controlled by the movement of the control handle. Push the control handle forward from neutral to the first detent for forward gear. Continue pushing forward to increase speed. Pull the control handle back from neutral to the first detent for reverse gear. Continue pulling back to increase speed.

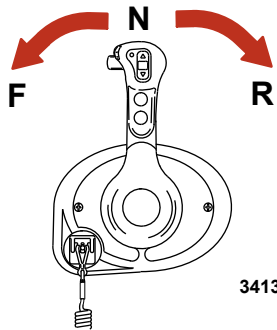

2. Shift lock - Pressing the shift lock allows the engine to shift. The shift lock must always be pressed when moving the control handle out of the neutral position.

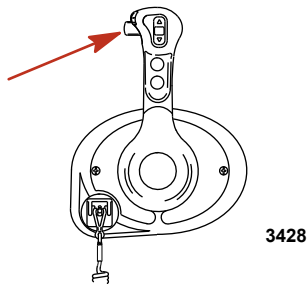

3. Trim switch (if equipped) - Pressing the trim switch will trim the engine up or down.

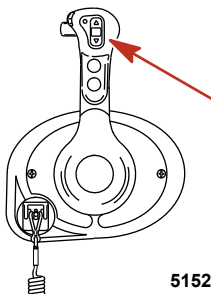



# FEATURES AND CONTROLS

4. Throttle only button - Allows the boat operator to increase engine RPM for warm-up, without shifting the engine into gear. To engage throttle only, move the control handle into the neutral position. Press the throttle only button while moving the control handle ahead to the forward detent. The horn indicates throttle only is engaged. Advance throttle to increase engine RPM. To disengage, return the control handle to the neutral position. Engine RPM is limited to prevent engine damage.

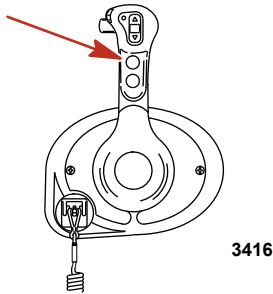

5. Stop/start button - Allows the boat operator to start or stop the engine without using the ignition key. The ignition key must be in the "ON" position to start the engine.

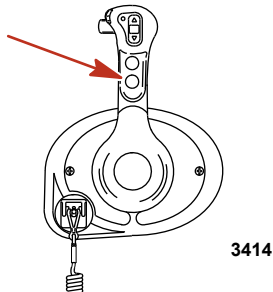

6. Lanyard stop switch - Turns the ignition off whenever the operator (when attached to the lanyard) moves far enough away from the operator's position to activate the switch.

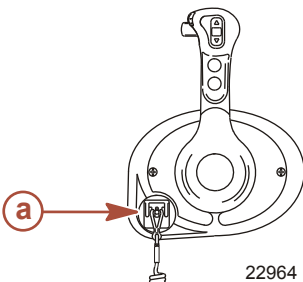

**a** - Lanyard stop switch

# FEATURES AND CONTROLS

- Control handle tension adjustment screw - This screw can be adjusted to increase or decrease the tension on the control handle (cover must be removed). This will help prevent unwanted motion of the handle in rough water. Turn screw clockwise to increase tension and counterclockwise to decrease tension. Adjust to tension desired.
- Detent tension adjustment screw - This screw can be adjusted to increase or decrease the effort to move control handle out of detent positions (cover must be removed). Turning the screw clockwise will increase tension. Adjust to tension desired.

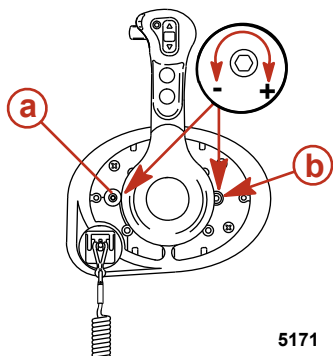

- a** - Detent tension adjustment screw  
**b** - Control handle tension adjustment screw

5171

## Slim Binnacle Control Features and Operation

### DTS SLIM BINNACLE SINGLE HANDLE CONSOLE FEATURES AND OPERATION

- Operation of shift and throttle is controlled by the movement of the control handle. Push the control handle forward from neutral to the first detent for forward gear. Continue pushing forward to increase speed. Pull the control handle back from neutral to the first detent for reverse gear. Continue pushing back to increase speed.

# FEATURES AND CONTROLS

2. Trim Switch (if equipped) - When the power trim switch is activated on the ERC handle, the DTS command module senses a closed circuit for either up or down trim. The DTS command module formulates a signal and sends it to the PCM. The PCM closes the ground circuit to the up or down trim relay.

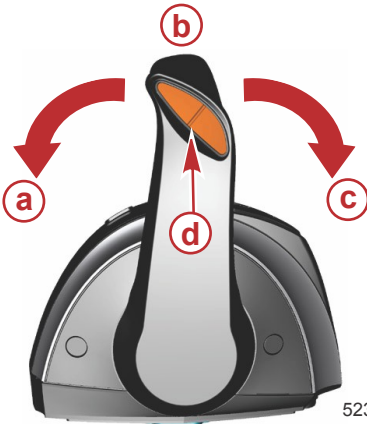

- a - Forward
- b - Neutral
- c - Reverse
- d - Trim switch

52360

3. Detent tension adjustment screw - This screw can be adjusted to increase or decrease the effort to move control handle out of detent positions. Turning screw clockwise will increase tension. Adjust to tension desired.
4. Control handle tension adjustment screw - This screw can be adjusted to increase or decrease the tension on the control handle. This will help prevent unwanted motion of the remote control handle in rough water. Turn screw clockwise to increase tension and counterclockwise to decrease tension. Adjust to tension desired.

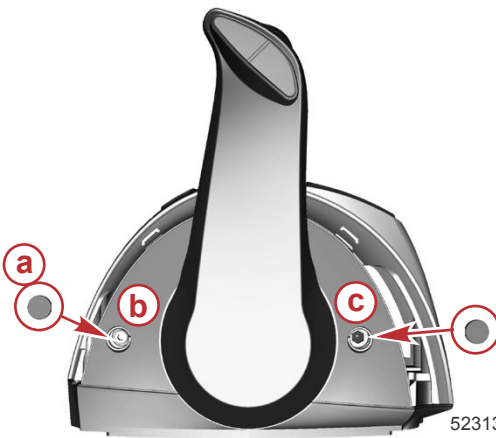

- a - Caps (2)
- b - Detent tension adjustment
- c - Control handle tension adjustment

52313

**NOTE:** The control handle tension and detent tension screws may require periodic maintenance adjustment.

# FEATURES AND CONTROLS

## Special Digital Throttle and Shift (DTS) Features

The DTS system features several alternate operational modes for the electronic remote control (ERC) levers.



**Slim binnacle ERC**

Item	Control	Function
a	Trim control (handle)	Raises and lowers the engine for best efficiency, or for conditions such as shallow water, trailering, etc.
b	"Stop/Start"	Allows the operator to start or stop the engine without the use of the key switch. The key switch must be in the run position for the start/stop switch to function.
c	"Transfer"	Allows boat control to be transferred to a different helm.
d	"Throttle-only"	Allows the boat operator to increase engine RPM for warm-up without shifting the transmission into gear.
e	"+"	Increases brightness settings for CAN pad, VesselView and SmartCraft gauges.
f	"_"	Decreases brightness settings for CAN pad, VesselView and SmartCraft gauges.
g	"Dock"	Reduces control lever operation throttle capacity to approximately 50% of normal control lever throttle demand.

# FEATURES AND CONTROLS

Item	Control	Function
h	Neutral light	Illuminates when the drive is in the neutral gear position. The lights flash when the engine is in throttle only mode.

## HELM TRANSFER

Some boats are designed to allow control of the vessel from more than one location. These locations are commonly referred to as helms or stations. Helm transfer is a term used to describe the method of transferring control from one helm (or station) to another helm.

### ▲ WARNING

**Avoid serious injury or death from loss of boat control. The boat operator should never leave the active station while engine is in gear. Helm transfer should only be attempted while both stations are manned. One-person helm transfer should only be performed while engine is in neutral.**

The helm transfer function allows the boat operator to select which helm is in control of the vessel. Before a transfer can be initiated the ERC levers at the active helm and at the helm intended for the transfer must be in the neutral position.

**NOTE:** *If you attempt to transfer helm control when the ERC levers are not in neutral, a beep will sound and the helm transfer will not succeed until the levers at the helms are moved to neutral and transfer is requested again.*

Some fault codes may appear on VesselView if other control or navigation functions are attempted after the helm transfer procedure is started. To remove the fault codes it may be necessary to cycle the key switch off and on, and then restart the helm transfer procedure. Ensure that other control and navigation inputs are performed after helm transfer is complete to avoid setting fault codes.

### NOTICE

**The ERC levers must be in neutral to perform a helm transfer. While in neutral your vessel could drift and collide with objects nearby resulting in damage. Keep an adequate look out while performing the helm transfer.**

To avoid damage, use extra care when attempting a helm transfer while the vessel is close to docks, piers, or other fixed items or when near other vessels.

## REQUESTING HELM TRANSFER

**NOTE:** *Any movement of the ERC levers after pressing the transfer button terminates the helm transfer request. A single beep sounds and the transfer button light turns off signaling the end of the transfer request.*

To request the transfer of vessel control from one helm to another:

# FEATURES AND CONTROLS

1. At the helm you are requesting be made active and with the ERC levers in neutral, press the transfer button one time. After the transfer button is pressed, the transfer button light turns on and one beep will sound confirming the impending transfer.



"Transfer" button

**NOTE:** If the ERC levers at the helms are not in neutral, the neutral lights will flash. Move all the ERC levers to neutral and the neutral light will stop flashing.

2. With the transfer button light and neutral light on, press the transfer button a second time to complete the helm transfer.
3. When the helm transfer is complete, another beep sounds and the transfer button light turns off.

**NOTE:** If the helm transfer is not completed in 10 seconds, the request is automatically cancelled, a double beep sounds and control will remain at the existing active helm. Press the transfer button again to start the helm transfer.

4. The helm where the transfer request was initiated, is now active and controls the vessel.

## THROTTLE-ONLY

Throttle-only allows the operator to increase the engine RPM for warm-up without shifting the engine into gear. To engage throttle-only mode:

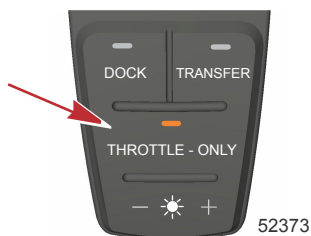

"Throttle-Only" button

1. Place the ERC lever in neutral.
2. Press the "Throttle-Only" button. The button light will turn on and the neutral lights will blink.

# FEATURES AND CONTROLS

3. Place either ERC lever into gear. The warning horn will beep each time the lever is moved in and out of gear while in throttle only, but will remain in neutral.
4. The RPM of the engines can be increased.

**NOTE:** Pressing the "Throttle-Only" button while the ERC lever is not in the neutral position, turns the button light off and remains in throttle-only mode. You must place the ERC lever into the neutral position to disengage throttle-only mode.

To disengage throttle-only mode:

1. Place the ERC lever into neutral. Throttle-only will not disengage unless the ERC lever is in neutral.
2. Press the "Throttle-Only" button. The button light will turn off.
3. The neutral lights stop flashing and remain illuminated.

## DOCK

Dock mode reduces throttle capacity to approximately 50% of normal throttle demand, allowing finer control of engine power in close quarter situations. If more power is needed for vessel maneuvering when environmental conditions require more thrust, disable dock mode to return the engine control to full thrust capability.

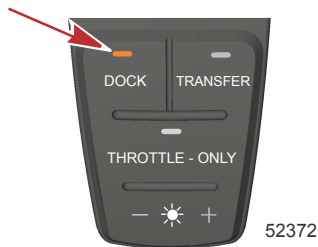

**"DOCK" button**

# FEATURES AND CONTROLS

## Dual-Handle Console Control Features and Operation

### DUAL-HANDLE ELECTRONIC REMOTE CONTROL (ERC)— OPERATION AND ADJUSTMENT

#### Operation

The electronic remote control (ERC) handle controls the shift and throttle operation. Push the control handle forward from neutral to the first detent for forward gear. Continue pushing the handle forward to increase speed. Pull the control handle from the forward position to the neutral position to decrease speed and eventually stop. Pull the control handle back from neutral to the first detent for reverse gear. Continue pulling the handle back to increase speed in reverse.



51902

- a** - Forward
- b** - Neutral
- c** - Reverse

The amount of force needed to move the handles and to move the handles through the detents is adjustable to help prevent unwanted motion.

#### Adjustment

**NOTE:** *The control handle tension and detent tension may require periodic maintenance using the adjustment screws.*

To adjust the handle detent tension:

1. Remove the side cover plugs of the handle that needs adjustment.
2. Turn the adjustment screw clockwise to increase tension on the control handle and counterclockwise to decrease tension.
3. Adjust to the tension desired.



# FEATURES AND CONTROLS

To adjust handle tension:

1. Remove the side cover plugs of the handle that needs adjustment.
2. Turn the adjustment screw clockwise to increase tension on the control handle and counterclockwise to decrease tension.
3. Adjust to the tension desired.

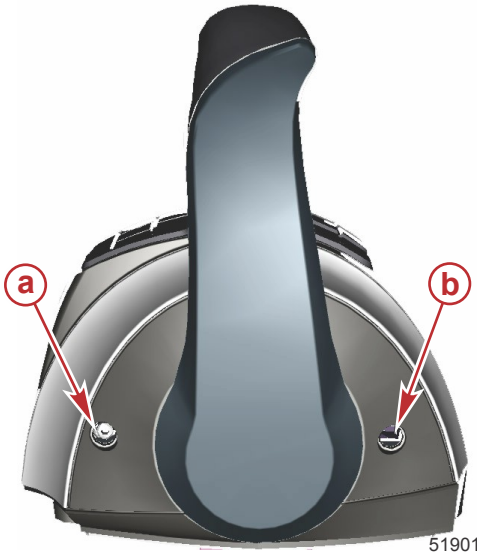

**a** - Detent tension adjustment screw

**b** - Handle tension adjustment screw

# FEATURES AND CONTROLS

## SPECIAL DIGITAL THROTTLE AND SHIFT (DTS) FEATURES

The DTS system features several alternate operational modes for the electronic remote control (ERC) levers. Any of the listed features can operate simultaneously.



55232

### Dual engine ERC

Item	Control	Function
a	Trim control (handle)	Raises and lowers the engines for best efficiency, or for conditions such as shallow water, trailering, etc.
b	NEUTRAL lights	Illuminate when the drive is in the neutral gear position. The lights flash when the engine is in throttle only mode.
c	TRANSFER	Allows boat control to be transferred to a different helm. Refer to <b>Helm Transfer</b> .
d	DOCK	Control lever operation reduces throttle capacity to approximately 50% of normal control lever throttle demand.
e	+	Increases brightness settings for CAN pad, VesselView and SmartCraft gauges.
f	THROTTLE ONLY	Allows the boat operator to increase engine RPM for warm-up without shifting the transmission into gear.

# FEATURES AND CONTROLS

Item	Control	Function
g	-	Decreases brightness settings for CAN pad, VesselView and SmartCraft gauges.
h	1 LEVER	Enables the throttle and shift functions of both engines to be controlled by the port lever.
i	SYNC	Turns off or on the auto-synchronization feature. Refer to <b>Sync</b> .

**NOTE:** Not all functions may be active.

## Dock

Dock mode reduces throttle capacity to approximately 50% of normal throttle demand, allowing finer control of engine power in close quarter situations.



**DOCK button**

## Throttle Only

**NOTE:** Throttle only mode should be used if the captain is not in command at the helm. Placing the ERC in throttle only mode will avoid unintended gear engagement. The engines will turn using the steering wheel and the RPM of the engines can be increased while in the throttle only mode, but the gear position will remain in neutral.



**THROTTLE ONLY button**

# FEATURES AND CONTROLS

To engage throttle only mode:

1. Place both ERC levers in neutral.
2. Press the THROTTLE ONLY button. The button light will turn on and the neutral lights will blink.
3. Place either ERC lever into gear. The warning horn will beep each time the levers are moved in and out of gear while in throttle only, but will remain in neutral.
4. The RPM of the engines can be increased.

**NOTE:** Pressing the THROTTLE ONLY button while the ERC levers are not in the neutral position, turns the button light off and remains in throttle only mode. You must place the ERC levers into the neutral position to disengage throttle only mode.

To disengage throttle only mode:

1. Place both ERC levers into neutral. Throttle only will not disengage unless the ERC levers are in neutral.
2. Press the THROTTLE ONLY button. The button light will turn off.
3. The neutral lights stop flashing and remain illuminated.

## 1 Lever

This feature commands both engines with a single lever on a dual engine application. This feature simplifies engine management during rough sea conditions by allowing you to use a single lever to command both engines simultaneously. It is not the same as the system feature called Sync.



**1 LEVER button**

To engage 1 Lever mode:

1. Place both ERC levers in neutral.
2. Press the 1 LEVER button. The button light will turn on.
3. Place the starboard ERC lever into gear.
4. When the handle is moved, the engines RPM and gear position is synchronized.

To disengage 1 Lever mode:

1. Place both ERC levers in neutral.

# FEATURES AND CONTROLS

2. Press the 1 LEVER button. The button light turns off.

## Sync

Sync is an automatic engine synchronization feature that is always on unless it is turned off. Sync monitors the position of both ERC levers. When both levers are within 10% of one another, the port engine synchronizes to the starboard engine's RPM. The SmartCraft system will automatically disengage sync after 95% of throttle position range to allow each engine the ability to reach maximum available RPM. Sync cannot engage until the engines are at a minimum speed.

The indicator light on the SYNC button is on when both engines are on. The light is yellow at idle and 95% of throttle and when the engines are not synchronized. The light turns red when the engines are synchronized.



**SYNC button**

The RPM display of VesselView also shows an orange icon under the RPM numbers if the engines RPMs differ more than 10% of each other, and the icon turns red when they are synchronized.

To disengage sync mode:

1. Place the ERC levers in any detent.
2. Press the SYNC button. The button light turns off.

To engage Sync mode, press the SYNC button at any time.

# FEATURES AND CONTROLS

## Transfer (Boats equipped with dual helms)

The TRANSFER button allows the boat operator to transfer control of the boat from the active helm to the inactive helm on boats equipped with dual helms. Refer to **Helm Transfer**.



TRANSFER button

## HELM TRANSFER

Some boats are designed to allow control of the vessel from more than one location. These locations are commonly referred to as helms or stations. Helm transfer is a term used to describe the method of transferring control from one helm (or station) to another helm.

### ⚠ WARNING

**Avoid serious injury or death from loss of boat control. The boat operator should never leave the active station while engine is in gear. Helm transfer should only be attempted while both stations are manned. One-person helm transfer should only be performed while engine is in neutral.**

The helm transfer function allows the boat operator to select which helm is in control of the vessel. Before a transfer can be initiated the ERC levers at the active helm and at the helm intended for the transfer must be in the neutral position.

**NOTE:** *If you attempt to transfer helm control when the ERC levers are not in neutral, a beep will sound and the helm transfer will not succeed until the levers at the helms are moved to neutral and transfer is requested again.*

Some fault codes may appear on VesselView if other control or navigation functions are attempted after the helm transfer procedure is started. To remove the fault codes it may be necessary to cycle the key switch off and on, and then restart the helm transfer procedure. Ensure that other control and navigation inputs are performed after helm transfer is complete to avoid setting fault codes.

# FEATURES AND CONTROLS

## NOTICE

The ERC levers must be in neutral to perform a helm transfer. While in neutral your vessel could drift and collide with objects nearby resulting in damage. Keep an adequate look out while performing the helm transfer.

To avoid damage, use extra care when attempting a helm transfer while the vessel is close to docks, piers, or other fixed items or when near other vessels.

## REQUESTING HELM TRANSFER

**NOTE:** Any movement of the ERC levers after pressing the TRANSFER button terminates the helm transfer request. A single beep sounds and the transfer button light turns off signaling the end of the transfer request.

To request the transfer of vessel control from one helm to another:

1. At the helm you are requesting be made active and with the ERC levers in neutral, press the TRANSFER button one time. After the TRANSFER button is pressed, the transfer button light turns on and one beep will sound confirming the impending transfer.



TRANSFER button

**NOTE:** If the ERC levers at the helms are not in neutral, the neutral lights will flash. Move all the ERC levers to neutral and the neutral light will stop flashing.

2. With the TRANSFER button light and neutral light on, press the TRANSFER button a second time to complete the helm transfer.
3. When the helm transfer is complete, another beep sounds and the transfer button light turns off.

**NOTE:** If the helm transfer is not completed in 10 seconds, the request is automatically cancelled and a double beep sounds. Control will remain at the existing active helm. Press the TRANSFER button again to restart helm transfer.

4. The helm where the transfer request was initiated is now active and controls the vessel.

# FEATURES AND CONTROLS

## Shadow Mode Control with CAN Trackpad Features and Operation

### TRIPLE ENGINE THROTTLE AND SHIFT OPERATION

Movement of the handles on the remote control allows the boat operator to control the engine throttle speed and gear shift positions of all three engines.

The throttle and shift function is dependant on what engines are running. Refer to the following table.

Port Engine	Center Engine	Starboard Engine	Control Handle Function
Running	Running	Running	Port engine throttle and shift = controlled by port control handle
			Starboard engine throttle and shift = controlled by starboard control handle
			Center engine throttle = average of port and starboard engines
			Center engine shift = neutral unless both engines are in the same gear
Running	Running	Off	Port and center engine throttle and shift = controlled by port control handle
Off	Running	Running	Starboard and center engine throttle and shift = controlled by starboard control handle
Running	Off	Running	Port engine throttle and shift = controlled by port control handle
			Starboard engine throttle and shift = controlled by starboard control handle
Running	Off	Off	Port engine throttle and shift = controlled by port control handle
Off	Off	Running	Starboard engine throttle and shift = controlled by starboard control handle
Off (ignition key switch turned on)	Running	Off (ignition key switch turned on)	Center engine throttle and shift = neutral/idle unless both control handles are in the same gear



# FEATURES AND CONTROLS

Turning off one of the outer engines while underway will cause the center engine to go into forced neutral/idle. Operation to the center engine can be restored by moving the control handle of the functioning outer engine back into neutral position and then engaging. The center engine speed and gear shift will then be controlled by the functioning outer engine.

Turning off the center engine while underway will have no effect on the operation of the outer engines.

If a failure should occur while underway which causes one of the outer engines into forced neutral/idle condition, the center engine will also be forced to neutral/idle. Operation to the center engine can be restored by moving the control handle of the functioning outer engine back into neutral and then engaging.

## QUAD ENGINE THROTTLE AND SHIFT OPERATION

Movement of the handles on the remote control allows the boat operator to control the engine throttle speed and gear shift positions of all four engines.

The throttle and shift function is dependent on what engines are running. The following table represents the most common quad engine vessel personality for shadow operation.

**IMPORTANT: Quad engine vessel personalities may vary on which engines are configured to be the master engines. It is possible to have the center engines as the master and the outer engines configured as the shadow engines. Therefore, the following table does not represent this type of vessel personality.**

Port Outer Engine	Port Inner Engine	Starboard Inner Engine	Starboard Outer Engine	Control Handle Function
Running	Running	Running	Running	Port inner and outer engines throttle and shift = controlled by port control handle
				Starboard inner and outer engines throttle and shift = controlled by starboard control handle
Running	Running	Off	Off	Port inner and outer engines throttle and shift = controlled by port control handle

## FEATURES AND CONTROLS

Port Outer Engine	Port Inner Engine	Starboard Inner Engine	Starboard Outer Engine	Control Handle Function
Off	Off	Running	Running	Starboard inner and outer engines throttle and shift = controlled by starboard control handle
Off (ignition key switch turned on)	Running	Running	Running	Port inner engine throttle and shift = controlled by port control handle
Running	Running	Running	Off (ignition key switch turned on)	Starboard inner engine throttle and shift = controlled by starboard control handle
Off (ignition key switch turned off)	Running	Running	Running	Port inner engine throttle and shift = controlled by starboard control handle
Running	Running	Running	Off (ignition key switch turned off)	Starboard inner engine throttle and shift = controlled by port control handle
Running	Off	Off	Running	Port outer engine throttle and shift = controlled by port control handle
				Starboard outer engine throttle and shift = controlled by starboard control handle
Off (ignition key switch turned on)	Running	Running	Off (ignition key switch turned on)	Port inner engine throttle and shift = controlled by port control handle
				Starboard inner engine throttle and shift = controlled by starboard control handle

# FEATURES AND CONTROLS

Turning off the starboard outer engine while underway will cause the starboard inner engine to go into forced neutral/idle. Operation to the inner engine can be restored by turning the starboard outer engine ignition key to the on position and moving the starboard control handle back into neutral position and then into gear. The inner engine speed and gear shift will then be controlled by the starboard control handle.

Turning off the port outer engine while underway will cause the port inner engine to go into forced neutral/idle. Operation to the inner engine can be restored by turning the port outer engine ignition key to the on position and moving the port control handle back into neutral position and then into gear. The inner engine speed and gear shift will then be controlled by the port control handle.

Turning off one of the inner engines while underway will have no effect on the operation of the outer engines.

If a failure should occur while underway which causes the starboard outer engine into forced neutral/idle condition, the inner starboard engine will also be forced to neutral/idle. Operation to the inner engine can be restored by moving the starboard control handle back into neutral and then into gear.

If a failure should occur while underway which causes the port outer engine into forced neutral/idle condition, the inner port engine will also be forced to neutral/idle. Operation to the inner engine can be restored by moving the port control handle back into neutral and then into gear.

## Hot Foot

### REQUIREMENTS FOR OPERATION OF A HOT FOOT

Engine speed is controlled from idle to WOT by either the foot throttle or the panel mount control handle. Hot foot throttle operation requires the DTS system be set up with a switch that can turn the hot foot throttle control off or on. This will allow the boat operator to select the throttle operation through the electronic remote control assembly or through the hot foot control assembly.

# FEATURES AND CONTROLS

## DTS HOT FOOT OPERATION

### DTS Hot Foot

DTS hot foot operation use is unique and is generally used on boats that can reach significant speeds. The use of a hot foot allows the operator to keep both hands on the steering wheel at all speeds, which allows the operator a greater control of the boat.

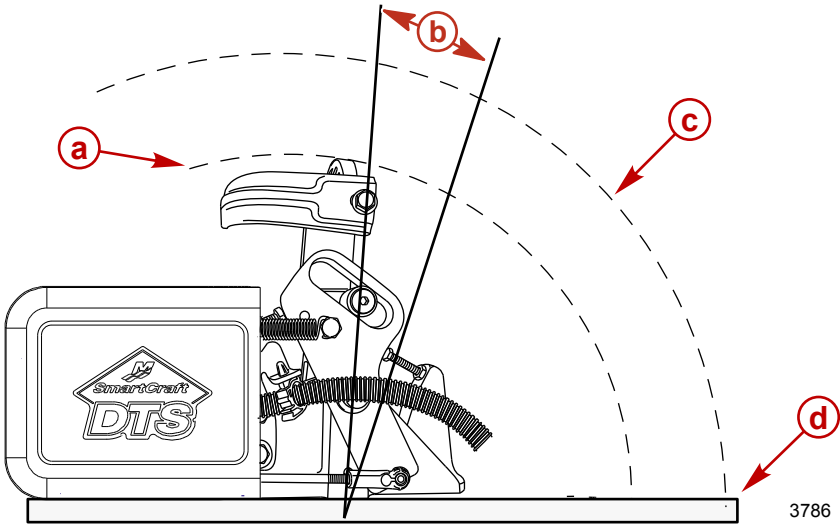

- a** - Pedal radius—241 mm (9.5 in.)
- b** - Maximum pedal travel—30°
- c** - Required added clearance for shoe
- d** - Boat deck

### Hand and Foot Control Operation with Hand Throttle On/Off Switch

1. Engine speed is controlled from idle to WOT by either the foot throttle or the panel mount control handle.
2. **The default setting when the engine is started:**
  - a. Throttle control at the foot throttle.
  - b. The hand throttle indicator light is off.
3. **To transfer throttle control to the panel mount remote control handle:**
  - a. Place the throttle control handle in neutral or in the forward/reverse detent position.
  - b. Push the hand throttle on/off switch button.
  - c. A single horn beep will sound.
  - d. The hand throttle indicator light is on.

# FEATURES AND CONTROLS

- e. Throttle control at the panel mount remote control handle.

**NOTE:** If the transfer fails, a double horn beep will sound.

## 4. To return throttle control to the foot throttle:

- a. Place the throttle control handle in neutral or in the forward/reverse detent position.
- b. Push the hand throttle on/off switch button.
- c. A single horn beep will sound.
- d. The hand throttle indicator light is off.
- e. Throttle control at the foot throttle.

**NOTE:** If the transfer fails, a double horn beep will sound.

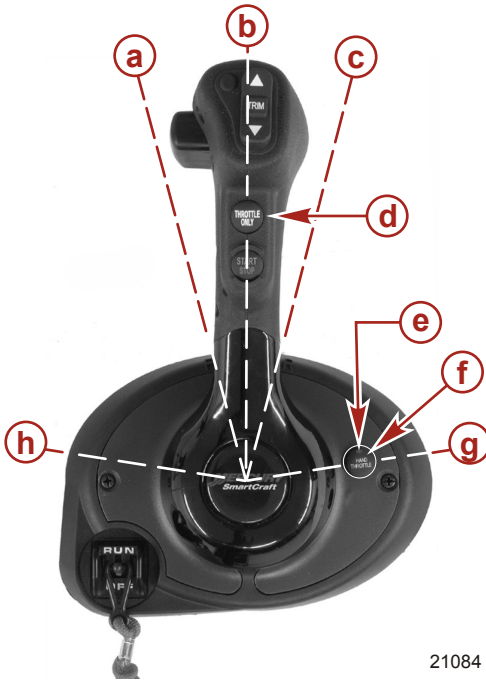

- a** - Forward detent position
- b** - Neutral detent position
- c** - Reverse detent position
- d** - Throttle only button
- e** - Hand throttle indicator light
- f** - Hand throttle on/off switch button
- g** - Full reverse position
- h** - Full forward position

# FEATURES AND CONTROLS

## Zero Effort Controls

Zero Effort controls allow the operator to control the shifting and throttle with separate control handles. Zero Effort controls are available in single, and multiengine applications including shadow mode operation.



58266

## Warning System

### WARNING HORN SIGNALS

When the key switch is turned to the ON position, the horn will turn on for a moment as a test to indicate the horn is working.

There are two types of warning horns to alert the operator of an active problem within the engine's operating system.

1. **Continuous six second beep:** Indicates a critical engine condition. Depending on the condition, the Engine Guardian system may engage and protect the engine by limiting power. You should return to port immediately and contact your servicing dealer.
2. **Intermittent short beeps for six seconds:** Indicates a noncritical engine condition. This condition does not require immediate attention. You may continue using your boat, however, depending on the nature of the problem, the engine's power may be limited by the Engine Guardian system. Refer to **Engine Guardian System**. You should contact your servicing dealer at your earliest convenience.

It is important to note that in either of the above scenarios, the horn will only sound one time. If you key the engine off and restart it, the horn will sound again, one time, if the fault is still present. For visual display of the specific engine functions and additional engine data, refer to **SmartCraft Product**.

A few of the noncritical conditions indicated by the intermittent short beeps for six seconds can be corrected by the operator. These operator correctable conditions are as follows:

# FEATURES AND CONTROLS

- Water in the vessel mounted fuel filter. Refer to **Maintenance - Vessel Mounted Water-Separating Fuel Filter**.
- Cooling system (water pressure or engine temperature) problem. Stop the engine and check the water intake holes in the lower unit for obstruction.
- Low engine oil level. Refer to **Fuel and Oil - Checking and Adding Engine Oil**.

## ENGINE GUARDIAN SYSTEM

The Engine Guardian system monitors the critical sensors on the engine for any early indications of problems. Engine Guardian is functional whenever your engine is operating, so you never have to be concerned about whether or not you are protected. The system will respond to a problem by sounding the warning horn for six seconds and/or reducing engine power in order to provide engine protection.

If Engine Guardian has been activated, reduce the engine speed. The problem will need to be identified and corrected. The system must be reset before the engine will operate at higher speeds. Moving the throttle lever back to the idle position will reset the Engine Guardian system. If the Engine Guardian system has determined the reset has not corrected the problem, Engine Guardian will remain activated, limiting the throttle. The problem must be identified and corrected before Engine Guardian will allow the engine to reach a normal operating RPM.

## OVERSPEED REV LIMIT

The overspeed rev limit is set at an RPM greater than the operating range. In the event that the engine is operated at an RPM greater than or equal to the overspeed limit, the PCM does not allow the engine to maintain the power requested by the operator. Refer to **Specifications** to determine this engine's RPM limit.

Upon reaching the beginning of the rev limit, Engine Guardian will reduce the throttle plate opening. There is no audible warning while Engine Guardian overspeed limit is active.

To reset the Engine Guardian protection:

1. Completely reduce the throttle for three seconds.
2. Engage the throttle. If the engine does not respond, repeat step one.

## SMARTCRAFT PRODUCT

A Mercury SmartCraft System instrument package can be purchased for this outboard. A few of the functions the instrument package will display are engine RPM, coolant temperature, oil pressure, water pressure, battery voltage, fuel consumption, and engine operating hours.

The SmartCraft instrument package will also aid in Engine Guardian diagnostics. The SmartCraft Instrument package will display critical engine alarm data and potential problems.

# FEATURES AND CONTROLS

## Power Trim and Tilt

The outboard has a trim/tilt control called power trim. This enables the operator to easily adjust the position of the outboard by pressing the trim switch. Moving the outboard in closer to the boat transom is called trimming in or trimming down. Moving the outboard further away from the boat transom is called trimming out or trimming up. The term trim generally refers to the adjustment of the outboard within the first 20° range of travel. This is the range used while operating the boat on plane. The term tilt is generally used when referring to adjusting the outboard further up out of the water. With the engine not running and the key switch in the ON position, the outboard can be tilted out of the water. At speeds below 4300 RPM, the outboard can be tilted up past the normal trim range.

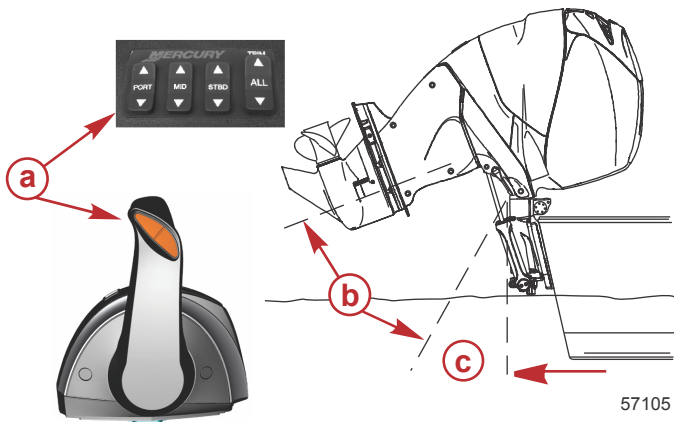

- a - Trim switch
- b - Tilt range of travel
- c - Trim range of travel

## POWER TRIM OPERATION

With most boats, operating around the middle of the trim range will give satisfactory results. However, to take full advantage of the trimming capability there may be times when you choose to trim the outboard all the way in or out. Along with an improvement in some performance aspects comes a greater responsibility for the operator, this being an awareness of some potential control hazards.

Consider the following lists carefully:

1. Trimming in or down can:
  - Lower the bow.
  - Result in quicker planing off, especially with a heavy load or a stern heavy boat.



# FEATURES AND CONTROLS

- Generally improve the ride in choppy water.
- In excess, can lower the bow of some boats to a point where they begin to plow with their bow in the water while on plane. This can result in an unexpected turn in either direction (called bow steering or oversteering) if any turn is attempted, or if a significant wave is encountered.

## **▲ WARNING**

**Operating the boat at high speeds with the outboard trimmed too far under can create excessive bow steer, resulting in the operator losing control of the boat. Install the trim limit pin in a position that prevents excessive trim under and operate the boat in a safe manner.**

2. Trimming out or up can:
  - Lift the bow higher out of the water.
  - Generally increase top speed.
  - Increase clearance over submerged objects or a shallow bottom.
  - In excess, can cause boat porpoising (bouncing) or propeller ventilation.
  - Cause engine overheating if any cooling water intake holes are above the waterline.

## TILTING TO FULL UP POSITION

### Tilt at Helm

**NOTE:** *The trim/tilt switch will remain active for 15 minutes after the ignition key switch has been turned off.*

1. If the ignition key switch has been turned off for over 15 minutes, turn it to the "ON" position.
2. Press the trim/tilt switch to the up position. The outboard will tilt up until the switch is released or it reaches its maximum tilt position.

### Tilt at Engine

The cowl mounted auxiliary tilt switch can be used to tilt the outboard with the key switch in the "OFF" position.

### Tilt Support Lever

1. Rotate the tilt support lever down.
2. Lower outboard until tilt support bracket rests on the pedestal.

# FEATURES AND CONTROLS

- Disengage the tilt support bracket, by raising the outboard up and rotating the tilt support lever up. Lower the outboard.

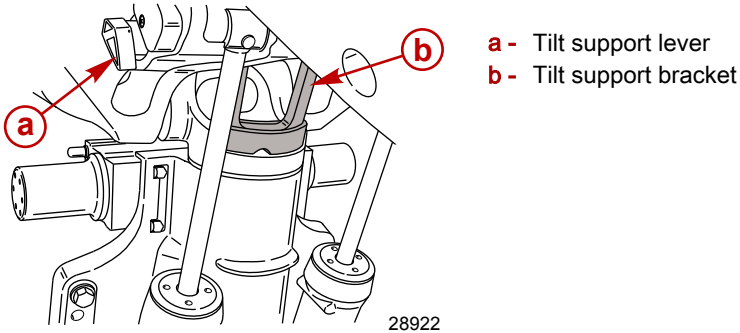

## MANUAL TILTING

If the outboard cannot be tilted using the power trim/tilt switch, the outboard can be manually tilted.

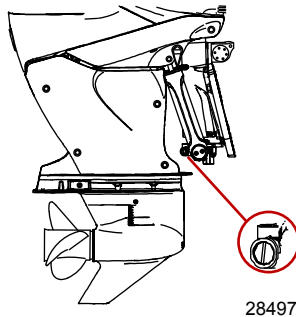

**NOTE:** The manual tilt release valve must be tightened before operating the outboard to prevent the outboard from tilting up during reverse operation.

Turn out the manual tilt release valve three turns counterclockwise. This allows manual tilting of the outboard. Tilt the outboard to the desired position and tighten the manual tilt release valve.

# FEATURES AND CONTROLS

## AUXILIARY TILT SWITCH

The auxiliary tilt switch can be used to tilt the outboard up or down using the power trim system.

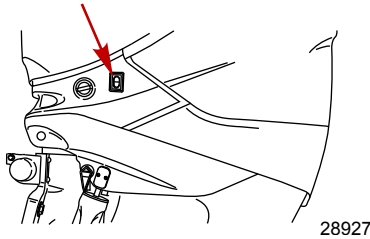

## SHALLOW WATER OPERATION

When operating your boat in shallow water, you can tilt the outboard beyond the maximum trim range to prevent hitting bottom.

1. Reduce engine speed below 4300 RPM.
2. Tilt outboard up. Make sure all the water intake holes stay submerged at all times.
3. Operate the engine at slow speed only. With the outboard tilted past 20° trim limit, the warning horn will sound and engine speed will be automatically limited to approximately 4300 RPM. The outboard must be tilted (trimmed) down below the maximum trim range to allow operation above 4300 RPM.

# OPERATION

## Important Daily Inspection Before Each Use

Any outboard mounted on the boat must have the mounting hardware inspected and checked to ensure that the hardware has not become loose. A decal on the transom bracket reminds the owner to check the fasteners securing the outboard to the transom before each use.

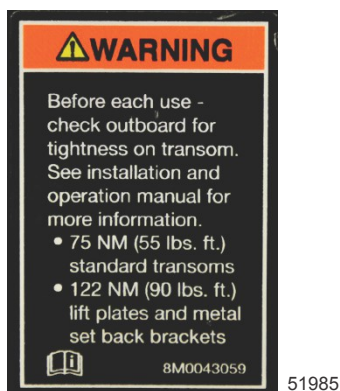

Decal on the transom bracket

## Prestarting Check List

- Operator knows safe navigation, boating, and operating procedures.
- An approved personal flotation device of suitable size for each person aboard and readily accessible (it is the law).
- A ring type life buoy or buoyant cushion designed to be thrown to a person in the water.
- Know your boats' maximum load capacity. Look at the boat capacity plate.
- Fuel supply OK.
- Arrange passengers and load in the boat so the weight is distributed evenly and everyone is seated in a proper seat.
- Tell someone where you are going and when you expect to return.
- It is illegal to operate a boat while under the influence of alcohol or drugs.
- Know the waters and area you will be boating; tides, currents, sand bars, rocks, and other hazards.
- Make inspection checks listed in **Maintenance - Inspection and Maintenance Schedule**.

# OPERATION

## Operating in Freezing Temperatures

When using your outboard or having your outboard moored in freezing or near freezing temperatures, keep the outboard tilted down at all times so the gearcase is submerged. This prevents the trapped water in the gearcase from freezing and causing possible damage to the water pump and other components.

If there is a chance of ice forming on the water, the outboard should be removed and drained completely of water. If ice should form at the water level inside the outboard driveshaft housing, it will block water flow to the engine causing possible damage.

## Operating in Saltwater or Polluted Water

We recommend that you flush the internal water passages of your outboard with fresh water after each use in salt or polluted water. This will prevent a buildup of deposits from clogging the water passages. Refer to **Maintenance - Flushing the Cooling System**.

If you keep your boat moored in the water, always tilt the outboard so the gearcase is completely out of water (except in freezing temperatures) when not in use.

Wash the outboard exterior and flush out the exhaust outlet of the propeller and gearcase with fresh water after each use. Each month, spray Mercury Precision or Quicksilver Corrosion Guard on external metal surfaces. Do not spray on corrosion control anodes as this will reduce the effectiveness of the anodes.

## Operating at High Elevations

Your engine automatically compensates for high elevation changes. A different pitch propeller may help reduce some normal performance loss resulting from reduced oxygen in the air. Consult your dealer.

## Propeller Selection

For best all around performance from your outboard/boat combination, select a propeller that allows the engine to operate in the upper half of the recommended full throttle RPM range with the boat normally loaded (refer to **General Information - Specifications**). This RPM range allows for better acceleration while maintaining maximum boat speed.

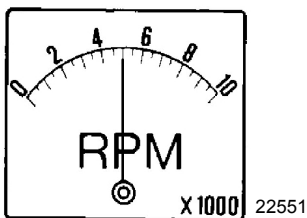

# OPERATION

If changing conditions cause the RPM to drop below the recommended range, such as warmer, more humid weather, operation at higher elevations, increased boat load, or a dirty boat bottom/gearcase, a propeller change or cleaning may be required to maintain performance and ensure the outboards durability.

Check full-throttle RPM, using an accurate tachometer, with the engine trimmed out to a balanced-steering condition (steering effort equal in both directions) without causing the propeller to break loose.

## Effects of Elevation and Weather on Performance

The following conditions may lower engine performance if the electronic management system is unable to compensate:

- Above sea level elevations
- High temperature
- Low barometric pressure
- High humidity

These conditions above reduce air density to the engine, which may lower the following:

- Boost pressure on supercharged engines
- Horsepower and torque throughout the RPM range
- Peak RPM
- Cranking compression

EXAMPLE: An engine running at an elevation of 8,000 feet will have over a 30% power loss while a loss of engine power on a hot and humid day could be as much as 14%. These losses apply to normally aspirated engines and may apply to supercharged engines.

### Compensating for power robbing conditions:

- Switch to lower pitch propeller
- Change gear ratio

Some boat performance can be improved by dropping to a lower pitch propeller, but engine performance will still remain lower. In some cases, a gear ratio reduction may be more beneficial. To optimize engine performance, prop the engine to allow it to operate at or near the top end of the recommended maximum RPM range at wide-open throttle with a normal boat load.

Other advantages to propeller changes:

- Enhances overall reliability and durability of the engine

# OPERATION

## Setting Trim Angle While Running Engine at Idle Speed

The exhaust relief hole on the outboard can become submerged on some boats if the engine is trimmed full in while running at idle speed. This may result in exhaust restriction, rough idle, excessive smoke, and fouled spark plugs. If this condition exists, trim outboard up until exhaust relief hole is out of the water.

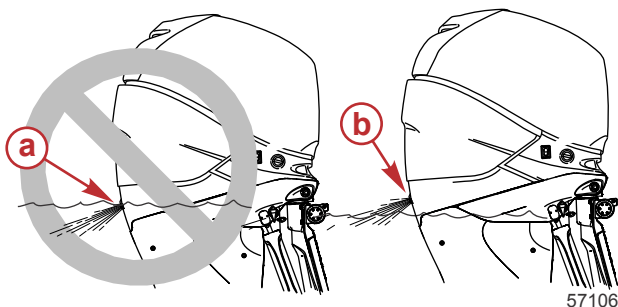

- a - Relief hole submerged (wrong)
- b - Relief hole above waterline (correct)

## Engine Break-in Procedure

**IMPORTANT:** Failure to follow the engine break-in procedures can result in poor performance throughout the life of the engine and can cause engine damage. Always follow break-in procedures.

1. For the first two hours of operation, run the engine at varied throttle settings up to 4500 RPM or at three-quarter throttle, and at full throttle for approximately one minute every ten minutes.
2. For the next eight hours of operation, avoid continuous operation at full throttle for more than five minutes at a time.

## Fuel Supply Module Priming Procedure

The fuel supply module (FSM) is not vented to the ambient air. The air trapped in the FSM, fuel lines, and fuel rail, will be slightly compressed during the initial ignition key "ON" with a dry or drained fuel system. Additional key "ON" events under these conditions, will not compress the air further to finish the priming of the FSM. Excessive number of key "ON" events may eventually damage the fuel pumps. The volume of air trapped in the FSM must be purged to prime the fuel system. This can be achieved by connecting a tool to the fuel rail Schrader valve fitting to quickly purge the system into an approved container, or by cranking the engine.

# OPERATION

## PRIMING THE FSM WITH A PURGE TOOL

The use of a purge tool for priming the FSM is the preferred method, but is not always practical. The objective is to purge the air entrained in the fuel system through a purge tool connected to the fuel rail Schrader valve test port. During the key "ON," opening the dump valve will allow the air to be purged from the FSM and fuel rail. This method should be used on vessels where the fuel inlet system to the outboard is restrictive; anti-siphon valve or holds a relatively large volume of fuel because of a long fuel supply line or water separating fuel filter. If a primer bulb is installed, it can be used during the priming event to shorten the amount of time required to start the engine.

1. Verify the engine is in a level vertical position.
2. Verify the vessel fuel supply line is connected to the outboard fuel system inlet fitting.
3. Connect a fuel pressure gauge to the fuel rail Schrader valve.
4. Secure the fuel pressure gauge purge hose into an appropriate fuel container to collect excess fuel.
5. Open the fuel pressure gauge purge valve and turn the ignition key "ON." The fuel pumps will run for approximately five seconds.
6. Turn the ignition key "OFF" and then back "ON." The fuel pumps will run for approximately five seconds. Continue this ignition key cycle until the purged fuel is relatively clear of air bubbles.

**NOTE:** *If the outboard fuel system does not prime within 15 key "ON" events, check for leaks in the fuel supply line to the outboard. Repair as needed. If no leak is found, the fuel supply system to the outboard may be too restrictive. Correct the condition and try again.*

7. Remove the fuel pressure gauge.
8. Turn the ignition key "ON." When the fuel pumps stop running, start the engine. The engine may not start on the first attempt. The engine will run rough at idle for up to two minutes while the residual air is purged from the fuel system.

## PRIMING THE FSM (RAN OUT OF FUEL CONDITION)

The use of a purge tool for priming the FSM is the preferred method, but is not always practical. When the vessel fuel system is void of fuel volume, it can be primed without the use of a purge tool. The objective is to purge the air entrained in the fuel system through the fuel injectors during engine cranking to allow fuel to enter the fuel module. This method can be used on vessels where the fuel inlet system to the outboard is less restrictive and holds a relatively small volume of fuel; a short fuel supply line, no water separating fuel filter, or water separating fuel filter is already primed. If a primer bulb is installed, it can be used during the priming event to shorten the amount of time required to start the engine.

1. Verify the engine is in a level vertical position.
2. Verify the vessel fuel supply line is connected to the outboard fuel system inlet fitting.



# OPERATION

3. Turn the ignition key "ON." The fuel pumps will run for approximately five seconds.
4. Turn the ignition key to the "START" position and release the key. The ECM controls the activation of the starter. The starter may continue cranking for up to eight seconds.

**NOTE:** When priming a drained fuel system, residual fuel may cause the engine to flare and stall which shortens the engine cranking event.

5. Continue with the ignition key "ON" and "START" sequence until the engine continues to run.

**IMPORTANT:** Allow the starter motor to cool for 20 to 30 seconds between full eight second crank events. Limit the number of events to a maximum of 10 full eight second cranking events.

6. Once the engine starts, it may run rough at idle for up to two minutes while the residual air is purged from the fuel system.
7. If the fuel system will not prime within 10 full eight second cranking events, use the previous procedure **Priming the FSM with a Purge Tool** to prime the fuel system.

## Starting the Engine

Before starting, read the **Prestarting Check List**, special operating instructions, **Engine Break-in Procedure**, **Gear Shifting**, and the remote control features and operation in the **Features and Controls** section.

### NOTICE

Without sufficient cooling water, the engine, the water pump, and other components will overheat and suffer damage. Provide a sufficient supply of water to the water inlets during operation.

1. Verify the cooling water intake is submerged.

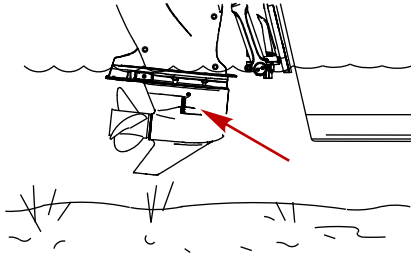

# OPERATION

2. Check the engine oil level.

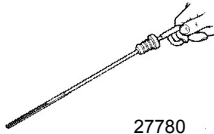

27780

3. Open the fuel tank vent on manual venting type tanks.

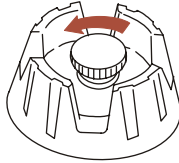

19748

4. Set the lanyard stop switch to the RUN position. Refer to **General Information - Lanyard Stop Switch**.

**NOTE:** The engine will not start unless the lanyard switch is set to the RUN position.



19791

# OPERATION

5. Shift the outboard to neutral (N) position.



51902

- a - Forward
- b - Neutral
- c - Reverse

**NOTE:** For initial start of a new engine or for an engine that ran out of fuel, refer to **Fuel Supply Module Priming Procedure**.

6. Ignition key starting - Turn the ignition key to the START position and release the key. The electronic starting system will automatically crank the engine for starting. If the engine fails to start, the engine will stop cranking. Turn the key to the START position again until the engine starts.

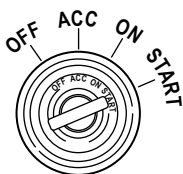

3485

7. After the engine starts, check for a steady stream of water flowing out of the water pump indicator hole.

**IMPORTANT:** If no water is coming out of the water pump indicator hole, stop the engine and check the cooling water intake for obstruction. No obstruction may indicate a water pump failure or blockage in the cooling system. These conditions will cause the engine to overheat. Have the outboard checked by your dealer. Operating the engine while overheated will cause engine damage.

# OPERATION

## Gear Shifting

### DTS PANEL MOUNT REMOTE CONTROL

**IMPORTANT:** Never shift outboard into gear unless engine speed is at idle. Do not shift outboard into forward or reverse when the engine is not running.

- The outboard has three gear shift positions to provide operation: Forward (F), Neutral (N), and Reverse (R).

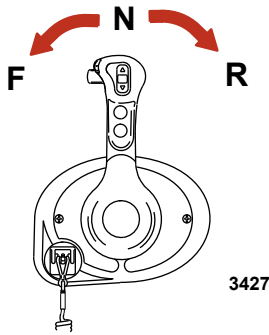

- When shifting, always stop at neutral position and allow the engine speed to return to idle.
- Panel mount remote control requires the operator to always press shift lock while moving the control handle out of the neutral position.

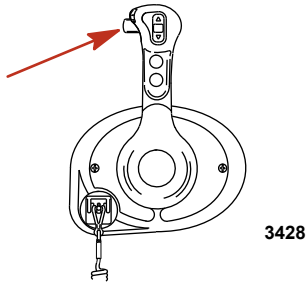

- Advance the control lever to further increase speed.

### DTS CONSOLE MOUNT REMOTE CONTROL

**IMPORTANT:** Never shift the outboard into gear unless the engine speed is at idle. Do not shift the outboard into forward or reverse when the engine is not running.

# OPERATION

- The outboard has three gear shift positions to provide operation: forward, neutral, and reverse.



- a** - Forward
- b** - Neutral
- c** - Reverse

- When shifting, always stop at neutral position and allow the engine speed to return to idle.
- Advance the control lever to further increase speed.

## ZERO EFFORT CONTROL GEAR SHIFTING

1. Verify the throttle lever is at the idle position.
2. Move the shift lever forward or reverse.

# OPERATION

3. Advance the throttle lever to apply power.

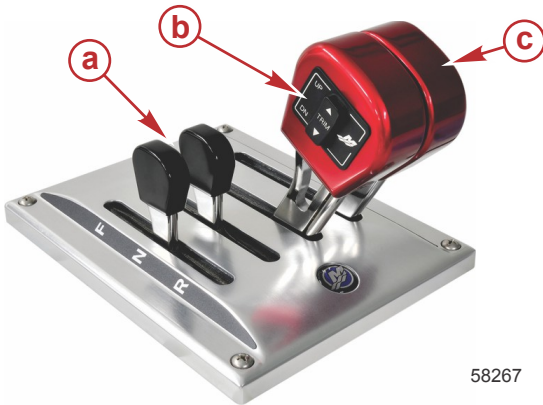

58267

- a - Shift levers in neutral position
- b - Trim switch
- c - Throttle levers at the idle position

## Stopping the Engine

**IMPORTANT:** Turning key to the "START" position while the engine is running will result in engine shut down, while leaving the DTS system active. This will allow the use of the power trim/tilt from the remote control handle.

Reduce engine speed and shift outboard to neutral position. Turn ignition key to "OFF" position.

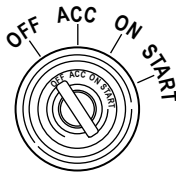

3482

# MAINTENANCE

## Outboard Care

To keep your outboard in the best operating condition, it is important that your outboard receive the periodic inspections and maintenance listed in the **Inspection and Maintenance Schedule**. We urge you to keep it maintained properly to ensure the safety of you and your passengers, and retain its dependability.

Record maintenance performed in the **Maintenance Log** at the back of this book. Save all maintenance work orders and receipts.

## SELECTING REPLACEMENT PARTS FOR YOUR OUTBOARD

We recommend using original Mercury Precision or Quicksilver replacement parts and Genuine Lubricants.

## EPA Emissions Regulations

All new outboards manufactured by Mercury Marine are certified to the United States Environmental Protection Agency, as conforming to the requirements of the regulations for the control of air pollution from new outboard motors. This certification is contingent on certain adjustments set to factory standards. For this reason, the factory procedure for servicing the product must be strictly followed and, wherever practicable, returned to the original intent of the design.

**Maintenance, replacement, or repair of the emission control devices and systems may be performed by any marine spark ignition (SI) engine repair establishment or individual.**

# MAINTENANCE

## EMISSION CERTIFICATION LABEL

An emission certification label, showing emission levels and engine specifications directly related to emissions, is placed on the engine at the time of manufacture.

<b>MERCURY</b>		<b>EMISSION CONTROL INFORMATION</b>	
THIS ENGINE CONFORMS TO <input type="checkbox"/> CALIFORNIA AND U.S. EPA EMISSION REGULATIONS FOR SPARK IGNITION MARINE ENGINES			
REFER TO OWNERS MANUAL FOR REQUIRED MAINTENANCE, SPECIFICATIONS, AND ADJUSTMENTS			
IDLE SPEED (in gear): <input type="text"/>		FAMILY: <input type="text"/>	
<input type="text"/> hp	<input type="text"/> L	HC+NOx:FEL: <input type="text"/> g/kWh	
<input type="text"/> kw	CO FEL: <input type="text"/> g/kWh		<input type="text"/>
<input type="text"/>	SPARK PLUG: <input type="text"/>		<input type="text"/>
		GAP: <input type="text"/>	
LOW PERM/HIGH PERM: <input type="text"/>			

43210

- a - Idle speed
- b - Engine horsepower
- c - Piston displacement
- d - Engine power - kilowatts
- e - Date of manufacture
- f - Family number
- g - Regulated emission limit for the engine family
- h - Regulated emission limit for the engine family
- i - Recommended spark plug and gap
- j - Percent of fuel line permeation

## OWNER RESPONSIBILITY

The owner/operator is required to have routine engine maintenance performed to maintain emission levels within prescribed certification standards.

The owner/operator is not to modify the engine in any manner that would alter the horsepower or allow emission levels to exceed their predetermined factory specifications.

## Inspection and Maintenance Schedule

### BEFORE EACH USE

- Check engine oil level. Refer to **Fuel and Oil - Checking and Adding Engine Oil**.
- Check that the lanyard stop switch stops the engine.
- Check the outboard for tightness to the boat transom. If any looseness of the outboard or mounting fasteners exists, tighten the outboard mounting fasteners.



# MAINTENANCE

Description	Nm	lb-in.	lb-ft
Outboard mounting fasteners–standard boat transom	75	–	55.3
Outboard mounting fasteners–metal lift plates and setback brackets	122	–	90

- Visually inspect the fuel system for deterioration or leaks.
- Check the steering system for binding or loose components.
- Visually check power steering fittings and hoses for leaks or signs of damage. Check tie bar fasteners (multiple outboard rigs) for proper tightness.
- Check propeller blades for damage.

## AFTER EACH USE

- Flush out the outboard cooling system if operating in salt or polluted water. Refer to **Flushing the Cooling System**.
- Wash off all salt deposits and flush out the exhaust outlet of the propeller and gearcase with fresh water if operating in saltwater.

## EVERY 100 HOURS OF USE OR ONCE YEARLY, WHICHEVER OCCURS FIRST

- Change the engine oil and replace the oil filter. The oil should be changed more often when the engine is operated under adverse conditions such as extended trolling. Refer to **Changing Engine Oil**.
- Inspect the hoses for cracks, chafe, and leaks. Replace as necessary.
- Check the outboard for tightness to the boat transom. If any looseness of the outboard or mounting fasteners exists, tighten the outboard mounting fasteners. This item should be service inspected by an authorized dealer once yearly.

Description	Nm	lb-in.	lb-ft
Outboard mounting fasteners–standard boat transom	75	–	55.3
Outboard mounting fasteners–metal lift plates and setback brackets	122	–	90

- Remove or replace the in-line fuel filter sleeve. Refer to **In-line Fuel Filter Sleeve Removal**.
- Check the accessory drive belt.
- Inspect the thermostat for corrosion and for a broken spring. Verify the thermostat closes completely at room temperature. This item should be serviced by an authorized dealer.

# MAINTENANCE

- Replace the vessel mounted fuel filter. Refer to **Vessel Mounted Water-Separating Fuel Filter**.
- Check corrosion control anodes. Check more frequently when used in saltwater. Refer to **Corrosion Control Anodes**.
- Drain and replace gearcase lubricant. Refer to **Gearcase Lubrication**.
- Check power steering fluid. Refer to **Checking Power Steering Fluid**.
- Inspect battery. Refer to **Battery Inspection**.
- Saltwater usage: Remove and inspect spark plugs for corrosion and replace spark plugs as necessary. Apply Anti-Seize Compound only on the threads of the spark plug prior to installation. Refer to **Spark Plug Inspection and Replacement**.

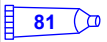
Tube Ref No.	Description	Where Used	Part No.
 81	Anti-Seize Compound	Spark plug threads	92-898101385

- Check wiring and connectors.
- Check tightness of bolts, nuts, and other fasteners.
- Check cowl seals to make sure seals are intact and not damaged.
- Check internal cowl sound reduction foam (if equipped) to ensure the foam is intact and not damaged.
- Check that the intake silencer (if equipped) is in place.
- Check that the idle relief muffler (if equipped) is in place.
- Check for loose hose clamps and rubber boots (if equipped) on the air intake assembly.

## EVERY 300 HOURS OF USE OR THREE YEARS

**IMPORTANT:** Engine oil must be drained before removing gearcase to avoid oil spillage. Perform scheduled water pump replacement in combination with an engine oil change.

- Inspect the front engine mounts (350 only). This item should be serviced by an authorized dealer.
- Replace water pump impeller (more often if overheating occurs or reduced water pressure is noted). This item should be serviced by an authorized dealer.
- Check power trim fluid. Refer to **Checking Power Trim Fluid**.
- Replace high-pressure in-line fuel filter. This item should be serviced by an authorized dealer.
- Replace spark plugs at first 300 hours or three years. After that, inspect spark plugs every 300 hours or three years. Replace spark plugs as needed. Refer to **Spark Plug Inspection and Replacement**.
- Replace accessory drive belt. Refer to **Accessory Drive Belt Inspection**.

# MAINTENANCE

## BEFORE PERIODS OF STORAGE

- Refer to storage procedure. Refer to **Storage** section.

## Flushing the Cooling System

Flush the internal water passages of the outboard with fresh water after each use in salt, polluted, or muddy water. This will help prevent a buildup of deposits from clogging the internal water passages.

**NOTE:** *The outboard can be tilted or in the vertical operating position during flushing.*

1. With the engine turned off, place the outboard in either the operating position (vertical) or in a tilted position.
2. Disconnect the flush connector from the fitting on the bottom cowl.

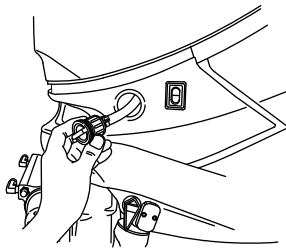

28726

3. Thread a water hose into the flush fitting.

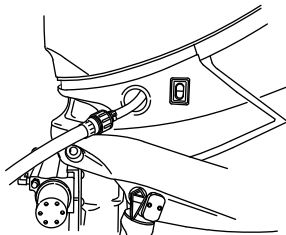

28727

4. Turn on the water tap (1/2 maximum) and let the water flush through the cooling system for about 15 minutes.
5. When flushing is complete, turn off water and disconnect the water hose.
6. Install the flushing connector to the fitting on the bottom cowl. Tighten the connector securely.

## Cowl Removal and Installation

### COWL REMOVAL

**IMPORTANT:** Most maintenance points are accessible by removing the top cowl only.

# MAINTENANCE

1. Pull up on the top cowl lock latch.

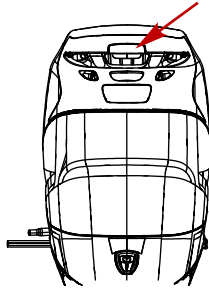

28946

2. Pull top cowl forward and lift off.
3. Pull lower cowl release latch up.
4. Remove rear cowl towards aft of outboard.

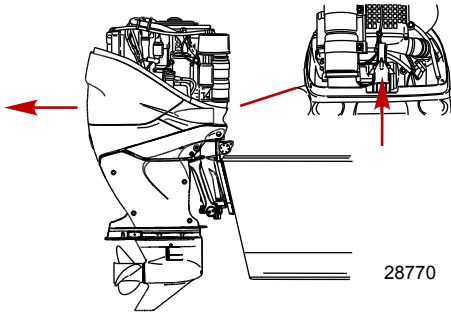

28770

## COWL INSTALLATION

1. Position lower cowl from aft side of outboard. Make sure it fits properly in the rubber seal.

# MAINTENANCE

2. Lock cowl in place by pulling lower cowl latch down.

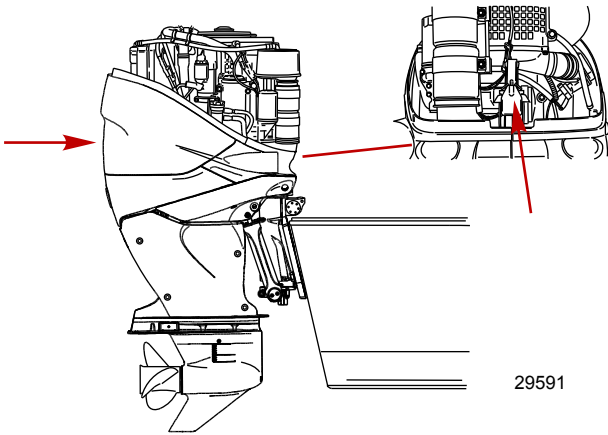

3. Place top cowl into position over engine, front first. Ensure cowl fits properly into the rubber seal.
4. The top cowl will lock into place when downward pressure is applied to the back side of cowl. Ensure cowl is securely fastened by pulling up on back of cowl.

## Cleaning Care for Top and Bottom Cowls

**IMPORTANT:** Dry wiping (wiping the plastic surface when it is dry) will result in minor surface scratches. Always wet the surface before cleaning. Do not use detergents containing hydrochloric acid. Follow the cleaning and waxing procedure.

### CLEANING AND WAXING PROCEDURE

1. Before washing, rinse the cowls with clean water to remove dirt and dust that may scratch the surface.
2. Wash the cowls with clean water and a mild nonabrasive soap. Use a soft clean cloth when washing.
3. Dry thoroughly with a soft clean cloth.
4. Wax the surface using a nonabrasive automotive polish (polish designed for clear coat finishes). Remove the applied wax by hand using a clean soft cloth.
5. To remove minor scratches, use Mercury Marine Cowl Finishing Compound (92-859026K 1).

# MAINTENANCE

## Cleaning Care for the Powerhead (Saltwater Use)

**IMPORTANT:** If the outboard is operated in saltwater, remove the top cowl. Inspect the powerhead and powerhead components for salt build-up. Wash off any salt build-up from the powerhead and powerhead components with fresh water. Keep water spray out of the air filter/intake and alternator. After washing, allow the powerhead and components to dry. Apply Quicksilver or Mercury Precision Lubricants Corrosion Guard spray on the external metal surfaces of the powerhead and powerhead components. Do not allow the Corrosion Guard spray to come in contact with the alternator drive belt, belt pulleys, or the outboard motor mounts. The alternator drive belt could slip and be damaged if it becomes coated with any lubricant or Corrosion Guard spray.

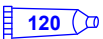
Tube Ref No.	Description	Where Used	Part No.
 120	Corrosion Guard	External metal surfaces of the powerhead and powerhead components.	92-802878 55

## Battery Inspection

The battery should be inspected at periodic intervals to ensure proper engine starting capability.

**IMPORTANT:** Read the safety and maintenance instructions which accompany your battery.

1. Turn off the engine before servicing the battery.
2. Ensure the battery is secure against movement.
3. Battery cable terminals should be clean, tight, and correctly installed. Positive to positive and negative to negative.
4. Ensure the battery is equipped with a nonconductive shield to prevent accidental shorting of battery terminals.

## Verado Engine Battery Specifications

**IMPORTANT:** Verado engines require a 12-volt absorbed glass mat (AGM) marine starting battery that meets the minimum ratings.

For best performance, Mercury Marine does not recommend using flooded (wet cell), gel cell type lead acid batteries, or lithium ion batteries for starting Verado engines.

Each Verado engine must be equipped with its own starting battery.

If the boat application requires additional battery loads for boat accessories or marine electronics, install an auxiliary battery, or batteries.

Choose a 12-volt absorbed glass mat (AGM) battery that meets the following ratings.

# MAINTENANCE

USA (SAE) Verado Starting Battery Rating	
Required Verado starting battery	12-volt absorbed glass mat (AGM) battery
Required marine cranking amps (MCA) and reserve capacity	800 minimum marine cranking amps with a minimum reserve capacity of 135 minutes RC25 rating

International (EN) Verado Starting Battery Rating	
Required Verado starting battery	12-volt absorbed glass mat (AGM) battery
Required cold cranking amps (CCA) and amp hours (Ah)	975 minimum cold cranking amps with a minimum of 65 amp hours

**NOTE:** Do not use an engine starting battery that does not meet the specified ratings. If a battery that does not meet the ratings is used, the electrical system may perform poorly.

**IMPORTANT:** Boating industry standards (BIA, ABYC, etc.), federal standards, and Coast Guard regulations must be adhered to when installing the battery. Ensure that the battery cable installation meets the pull test requirements and that the positive battery terminal is properly insulated in accordance with regulations.

It is recommended (required in some states) that the battery be installed in an enclosed case. Refer to regulations for your area.

When connecting the engine battery, hex nuts must be used to secure the battery leads to the battery posts. Tighten the hex nuts to the specified torque.

## ⚠ WARNING

Failure to properly secure the battery leads can result in a loss of power to the Digital Throttle and Shift (DTS) system, leading to serious injury or death due to loss of boat control. Secure the battery leads to the battery posts with hex nuts to avoid loose connections.

Description	Nm	lb-in.	lb-ft
Hex nuts	13.5	120	–

**IMPORTANT:** Battery cable size and length is critical. Refer to Battery Cable Size tables or engine installation manual for size requirements.

# MAINTENANCE

A decal advising against using deep cycle batteries and wing nuts should be placed on or near the battery box for future service reference. One 5/16 in. and one 3/8 in. hex nut are supplied per battery for wing nut replacement. Metric hex nuts are not supplied.

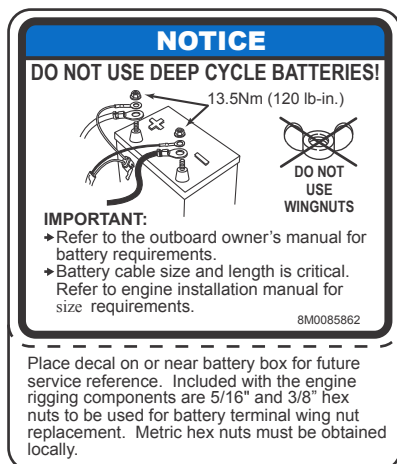

54395

## Air Filter (200–300)

The air filter assembly is a serviceable item and can be cleaned with warm soapy water if required.

### AIR FILTER REMOVAL AND CLEANING

1. Loosen air filter clamp screw.
2. Remove crankcase ventilation hose.

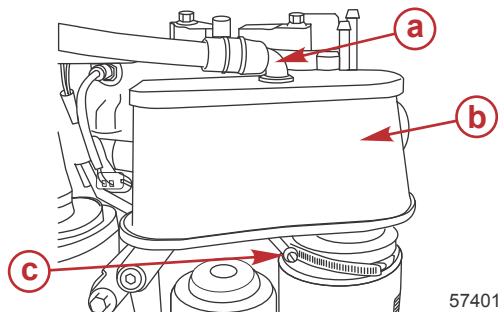

- a** - Crankcase ventilation hose
- b** - Filter assembly
- c** - Clamp screw

57401

3. Wash air filter assembly in warm soapy water.
4. Dry filter assembly with compressed air.
5. Apply 4 Stroke 10W30 Outboard Oil on a rag or towel and lightly pad air filter element. Wipe off excess oil. The air filter element should be moist to the touch.



# MAINTENANCE

Tube Ref No.	Description	Where Used	Part No.
110 	4 Stroke 10W30 Outboard Oil	Air filter element	92-858045K01

## AIR FILTER INSTALLATION

1. Install crankcase ventilation hose.
2. Install air filter assembly and tighten clamp screw securely.

## Air Filter (350, 350 Pro)

The air filter is an integral component of the flywheel guard. It should be inspected for debris whenever the top cowl is removed. A damp towel is usually sufficient to remove accumulated particles from the screen.

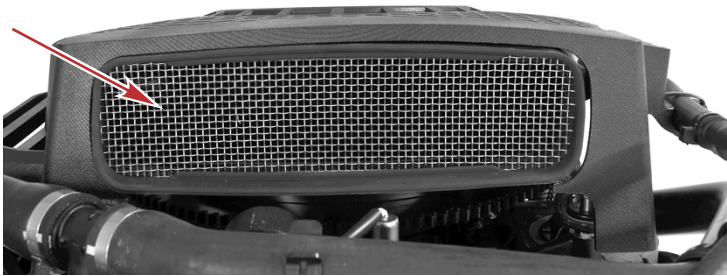

57281

## Fuel System

### WARNING

Fuel is flammable and explosive. Ensure that the key switch is off and the lanyard is positioned so that the engine cannot start. Do not smoke or allow sources of spark or open flame in the area while servicing. Keep the work area well ventilated and avoid prolonged exposure to vapors. Always check for leaks before attempting to start the engine, and wipe up any spilled fuel immediately.

**IMPORTANT:** Use an approved container to collect and store fuel. Wipe up spilled fuel immediately. Material used to contain spilled fuel must be disposed of in an approved receptacle.

Before servicing any part of the fuel system:

1. Stop engine and disconnect the battery.
2. Perform fuel system service in a well-ventilated area.
3. Inspect any completed service work for sign of fuel leakage.

# MAINTENANCE

## FUEL LINE INSPECTION

Visually inspect the fuel line for cracks, swelling, leaks, hardness, or other signs of deterioration or damage. If any of these conditions are found, the fuel line must be replaced.

## IN-LINE FUEL FILTER SLEEVE REMOVAL

This engine is equipped with an in-line fuel filter sleeve installed in the fuel inlet hose, inside the engine cowl. The filter captures debris that may be in the fuel line after the vessel mounted fuel filtration system. This filter must be removed after 100 hours of operation and may be either discarded or replaced with a new filter.

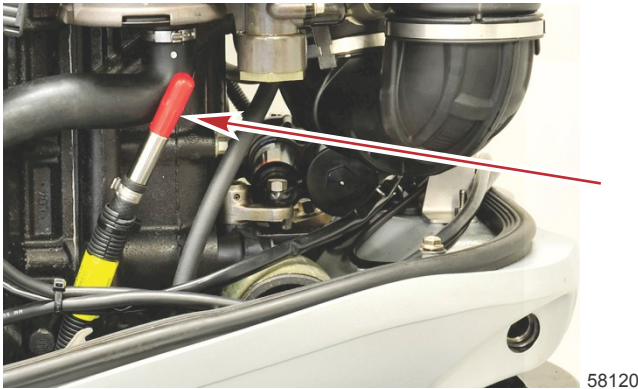

**Fuel inlet hose location**

1. Remove the clamp securing the vessel fuel line to the fuel inlet hose and remove the fuel line from the inlet hose.
2. Remove the in-line fuel filter sleeve from the inlet hose. Discard or replace the filter.

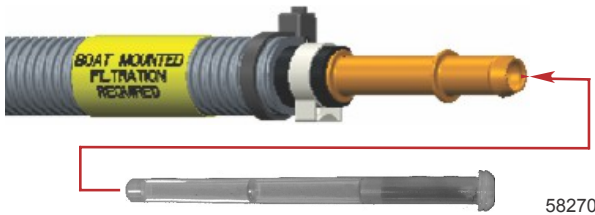

3. Install the vessel fuel line onto the fuel inlet hose and secure the connection with a clamp.
4. Verify the fuel line connection does not have a fuel leak.

# MAINTENANCE

## VESSEL MOUNTED WATER-SEPARATING FUEL FILTER

This engine requires a vessel mounted water-separating fuel filter. The filter should be replaced annually or every 100 hours, whichever occurs first.

### ⚠ WARNING

Fuel is flammable and explosive. Ensure that the key switch is off and the lanyard is positioned so that the engine cannot start. Do not smoke or allow sources of spark or open flame in the area while servicing. Keep the work area well ventilated and avoid prolonged exposure to vapors. Always check for leaks before attempting to start the engine, and wipe up any spilled fuel immediately.

### Filter Replacement

1. Close the fuel valve, if equipped.
2. Place a container under the fuel filter.
3. Remove the water-in-fuel sensor and allow the filter to drain into the container. The liquid that has drained from the filter must be disposed of according to applicable regulations and law.

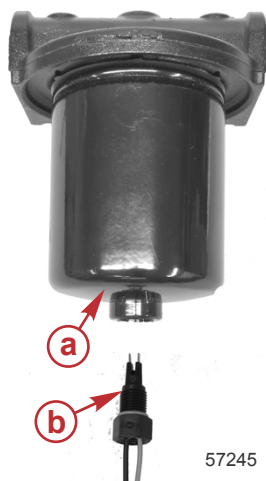

- a - Water-separating fuel filter
- b - Water-in-fuel sensor

4. Remove the filter by turning it counterclockwise. Dispose of the filter according to applicable regulations and law.
5. Lubricate the new filter seal with oil. Do not use grease.
6. Install the filter and tighten securely.
7. Lubricate the sensor O-ring with clean engine oil.
8. Install the water-in-fuel sensor and tighten it to the specified torque.

Description	Nm	lb-in.	lb-ft
Water-in-fuel sensor	2.5	22.1	–

# MAINTENANCE

9. Open the fuel valve, if equipped.
10. Start the engine and inspect the area for fuel leaks. Repair as required.

**NOTE:** After replacing the water-separating fuel filter, the engine may stall or develop a slight hesitation and should clear itself of entrained air within a few minutes. Allow the trapped air to be purged from the fuel system before operating the engine above idle in gear.

## Water-In-Fuel Warning—Draining the Filter

1. Close the fuel valve, if equipped.
2. Place a container under the fuel filter.
3. Remove the water-in-fuel sensor and allow the filter to drain into the container. The liquid that has drained from the filter must be disposed of according to applicable regulations and law.
4. Lubricate the sensor O-ring with clean engine oil.
5. Install the water-in-fuel sensor and tighten it to the specified torque.

Description	Nm	lb-in.	lb-ft
Water-in-fuel sensor	2.5	22.1	–

6. Open the fuel valve.
7. Start the engine and inspect the area for fuel leaks. Repair as required.

**NOTE:** After draining the water-separating fuel filter, the engine may stall or develop a slight hesitation and should clear itself of entrained air within a few minutes. Allow the trapped air to be purged from the fuel system before operating the engine above idle in gear.

## Corrosion Control Anodes

The outboard has corrosion control anodes at different locations. An anode helps protect the outboard against galvanic corrosion by sacrificing its metal to be slowly eroded instead of the outboard metals.

Each anode requires periodic inspection, especially in saltwater, which will accelerate the corrosion. To maintain corrosion protection, always replace the anode before it is completely corroded. Never paint or apply a protective coating on the anode, as this will reduce the effectiveness of the anode.

# MAINTENANCE

Two anodes are located on each side of the gearcase, with a third positioned on the underside of the antivibration plate. Another anode is installed on the bottom of the pedestal. Two more anodes are located on the bottom of each power trim ram.

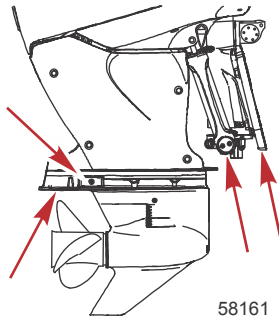

## Trim Wear Pad Replacement

The Verado engine utilizes thrust guide plates on either side of the driveshaft housing to improve stability of the engine. As the engine is trimmed up or down, the thrust guide plates will rub against the trim wear pads that are mounted on either side of the trim manifold. Replace the trim wear pads if the heads of the mounting screws become flush with the wear pad surface.

Refer to the **Inspection and Maintenance Schedule** for the proper maintenance interval.

# MAINTENANCE

**IMPORTANT:** Always use new mounting screws when installing trim wear pads.

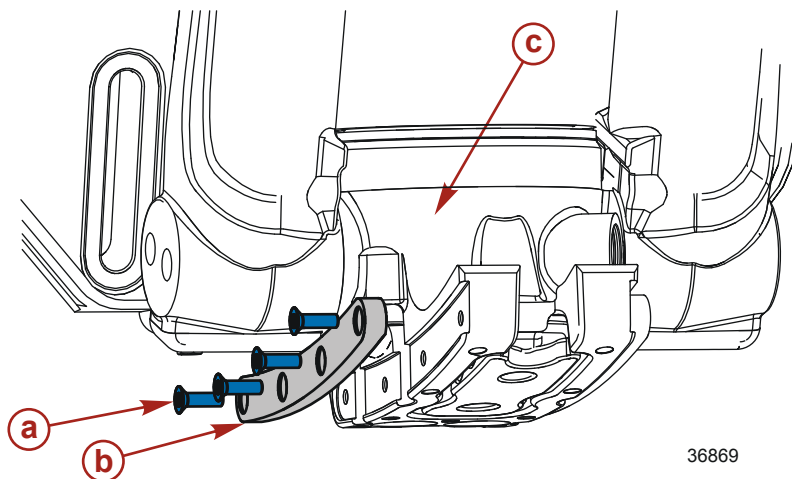

**a** - M6 x 20 screw with patch lock pad (8)

**b** - Trim wear pad (2)

**c** - Trim manifold

Description	Nm	lb-in.	lb-ft
M6 x 20 screw (8)	6	53	–

## Propeller Replacement

1. Shift the outboard into the neutral position.
2. Straighten the bent tabs on the propeller nut retainer.

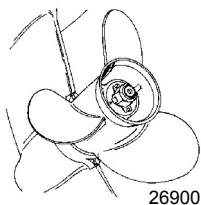

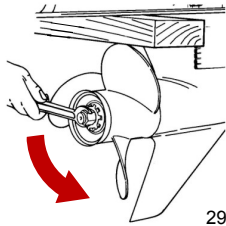

# MAINTENANCE

- Place a block of wood between the gearcase and the propeller to hold the propeller. Remove the propeller nut.



29592

- Pull the propeller straight off of the shaft.
- To aid in the future removal of the propeller, liberally coat the propeller shaft splines with one of the following Mercury products:

Tube Ref No.	Description	Where Used	Part No.
	Extreme Grease	Propeller shaft splines	8M0071842
 95	2-4-C with PTFE	Propeller shaft splines	92-802859A 1

- Flo-Torq II solid hub (200–300 non-HD):**

- Install the hub components in the sequence shown.

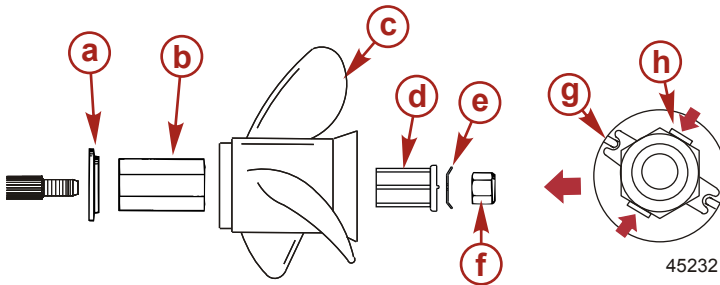

45232

## Flo-Torq II propeller without a hub bushing

- a** - Forward thrust washer
- b** - Drive sleeve
- c** - Propeller
- d** - Drive sleeve adapter
- e** - Propeller nut retainer
- f** - Propeller nut
- g** - Raised pins
- h** - Tabs bent against the locknut

# MAINTENANCE

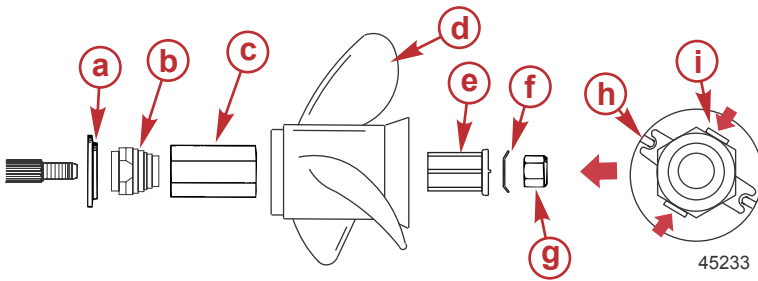

## Flo-Torq II propeller with a hub bushing

- a** - Forward thrust washer
- b** - Hub bushing
- c** - Drive sleeve
- d** - Propeller
- e** - Drive sleeve adapter
- f** - Propeller nut retainer
- g** - Propeller nut
- h** - Raised pins
- i** - Tabs bent against the locknut

- b. Place a block of wood between the gearcase and the propeller.  
Tighten the propeller nut to the specified torque.

Description	Nm	lb-in.	lb-ft
Propeller nut - propellers without a hub bushing	75	–	55.3
Propeller nut - propellers with a hub bushing	136	–	100

- c. Secure the propeller nut by bending the tabs of the retainer up against the flats on the nut.

## 7. Flo-Torq II HD solid hub (300–400 HD):



# MAINTENANCE

a. Install the hub components in the sequence shown.

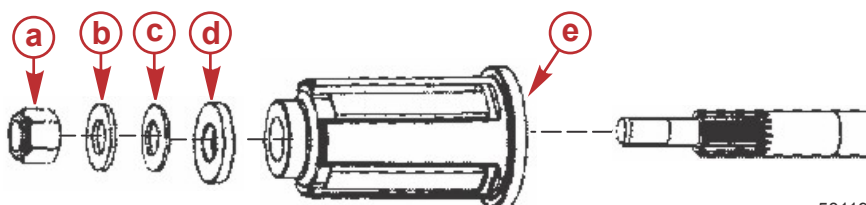

58119

- a** - Propeller nut
- b** - Washer, 38 mm (1.5 in.) diameter
- c** - Belleville washer, 38 mm (1.5 in.) diameter
- d** - Thick washer, 46 mm (1-13/16 in.) diameter
- e** - Propeller hub

b. Place a block of wood between the gearcase and the propeller.  
Tighten the propeller nut to the specified torque.

Description	Nm	lb-in.	lb-ft
Propeller nut	75	-	55.3

## Spark Plug Inspection and Replacement

1. Remove top and rear cowls. Refer to **Cowl Removal and Installation**.
2. Disconnect the wiring harness from the pencil coil connections.
3. Remove screws securing the coils.
4. Use a twisting motion, remove the pencil coils from the spark plugs.

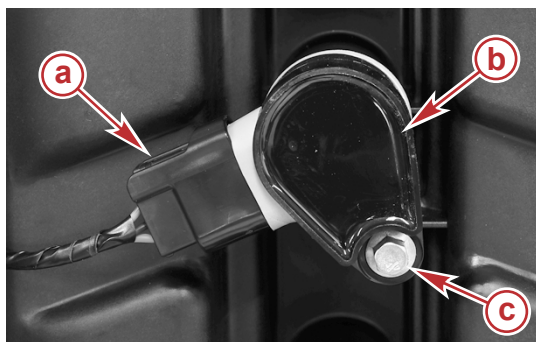

57247

- a** - Wiring harness connector
- b** - Pencil coil
- c** - Screw

# MAINTENANCE

- Remove the spark plugs. Replace the spark plug if the electrode is worn; the insulator is rough, cracked, broken, or blistered; or if the precious metal is not visible on the spark plug electrode.

**IMPORTANT: The color of the plug may not accurately reflect its condition. To accurately diagnose a faulty plug, inspect the precious metal on the plug's electrode. If no precious metal is visible, replace the plug.**

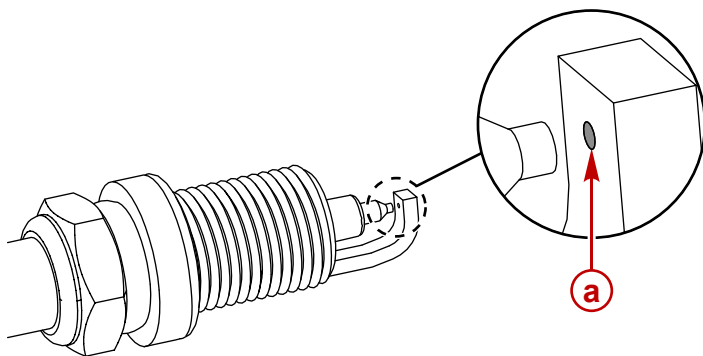

9381

**a** - Precious metal

- Set the spark plug gap. Refer to **General Information - Specifications**.

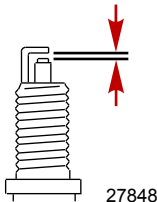

- All of the spark plugs should have the gap checked and corrected as necessary before installation.
  - Measure the gap with a feeler gauge or pin gauge. Never use a wedge-type gap checking tool to inspect or to adjust the gap.
  - If an adjustment is necessary, do not pry or apply any force on the center electrode. This is critical with any type of spark plug that has a wear surface, such as platinum or iridium added to either the ground electrode or the center electrode.
  - When it is necessary to widen the gap, use a tool that only pulls back on the ground electrode without touching the center electrode, the porcelain, or the wear portion of the ground electrode.
  - When it is necessary to close the gap, gently tap the plug ground electrode on a hard surface.
- Saltwater use - Apply Anti-Seize Compound only onto the threads of the spark plugs.

# MAINTENANCE

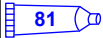
Tube Ref No.	Description	Where Used	Part No.
 81	Anti-Seize Compound	Spark plug threads	92-898101385

8. Before installing spark plugs, clean off any dirt on the spark plug seats. Install the plugs finger-tight and then tighten an additional 1/4 turn or tighten to the specified torque.

Description	Nm	lb-in.	lb-ft
Spark plug	27	–	20

9. Push pencil coils into place over the spark plugs using a twisting motion.  
10. Secure coil with the screw. Tighten the screw to the specified torque.

Description	Nm	lb-in.	lb-ft
Screw	8	71	–

11. Connect the wire harness to the pencil coil.

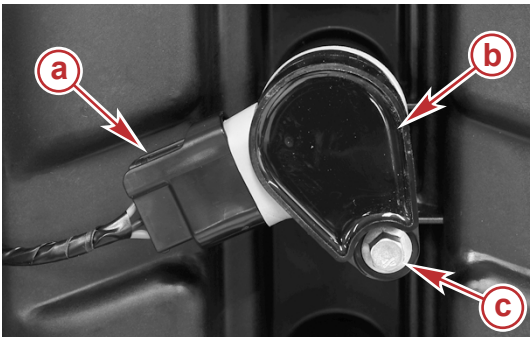

57247

- a** - Wiring harness connector
- b** - Pencil coil
- c** - Screw

12. Install the rear and top cowls.

## Fuses

**IMPORTANT:** An ATC fuse has the fuse element enclosed or sealed inside the plastic housing. This type of fuse must be used for marine applications. Marine applications are exposed to environments that may have the potential to accumulate explosive vapors. ATO fuses have exposed elements and should never be used in marine applications.

The electrical wiring circuits on the outboard are protected from overload with fuses. If a fuse is blown, try to locate and correct the cause of the overload. If the cause is not found, the fuse may blow again.

# MAINTENANCE

Remove the fuse puller from the holder.

Remove the cover from the fuse holder. Remove the suspected blown fuse and look at the silver band inside the fuse. If band is broken, replace the fuse. Replace the fuse with a new fuse with the same amp rating.

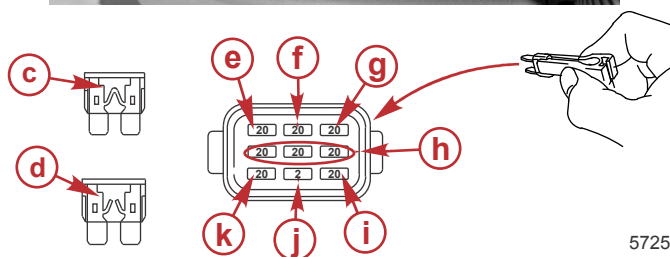
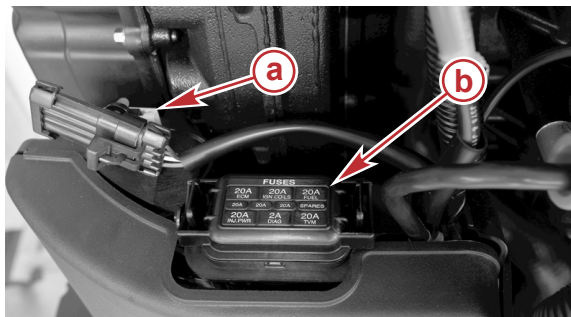

57250

- a** - Fuse puller
- b** - Fuse holder
- c** - Good fuse
- d** - Blown fuse
- e** - Electronic control module - 20 amp
- f** - Ignition coils - 20 amp
- g** - Fuel pumps - 20 amp
- h** - Spare fuses (3)
- i** - Thrust vector module - 20 amp (Joystick Piloting models only)
- j** - Diagnostics terminal - 2 amp
- k** - Fuel injectors - 20 amp

# MAINTENANCE

## DTS Wiring System

### ⚠ WARNING

Splicing or probing will damage the wire insulation allowing water to enter the wiring. Water intrusion may lead to wiring failure and loss of throttle and shift control. To avoid the possibility of serious injury or death from loss of boat control, do not splice or probe into any wire insulation of the DTS system.

- Verify the harnesses are not routed near sharp edges, hot surfaces, or moving parts.
- Verify all unused connectors and receptacles are covered with a weather cap.
- Verify the harnesses are fastened along the routing path.

## Accessory Drive Belt Inspection

1. Inspect the accessory drive belt tensioner to ensure the tensioner is within the recommended range of tension operation. If the tensioner arrow is within the red target area, have an authorized dealer replace the belt.

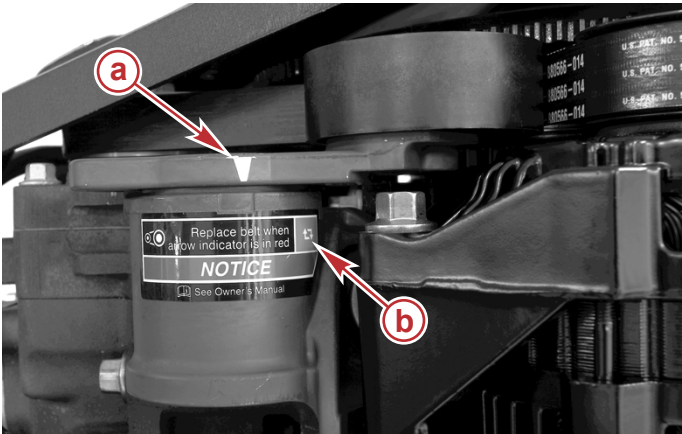

57255

- a** - Tensioner arrow
  - b** - Red target window (replace the belt)
2. Inspect the condition of the drive belt. If any of the following conditions are found, have an authorized dealer replace the belt.
    - Cracks in the back of the belt or in the base of V-grooves.
    - Excessive wear at the roots of the grooves.
    - Rubber portion swollen by oil.
    - Belt surfaces roughened.
    - Signs of wear on edges or outer surfaces of belt.

# MAINTENANCE

## Checking Power Trim Fluid

1. Tilt outboard to the full up position.
2. Rotate the tilt support bracket down.
3. Lower outboard until tilt support bracket rests on pedestal.
4. Remove the power trim fill cap. The fill cap only requires 1/4 turn to remove.

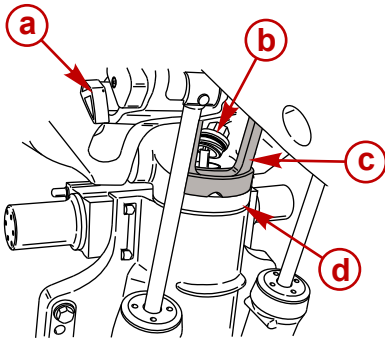

- a - Tilt support lever
- b - Power trim fill cap
- c - Tilt support bracket
- d - Pedestal

29312

5. The fluid level should be approximately 25 mm (1 in.) from the top of the fill neck. Add Quicksilver or Mercury Precision Lubricants Power Trim and Steering Fluid. If not available, use automotive automatic transmission fluid (ATF).

Tube Ref No.	Description	Where Used	Part No.
 114	Power Trim and Steering Fluid	Power trim system	92-858074K01

6. Install the power trim fill cap. Tighten fill cap 1/4 turn. Cap will snap in place. Do not tighten beyond this point.

# MAINTENANCE

## Checking Power Steering Fluid

Remove power steering cover and fill cap to check fluid level. The fluid level should be slightly below the bottom of the fill hole. Use SAE 0W-30 synthetic power steering fluid, if needed.

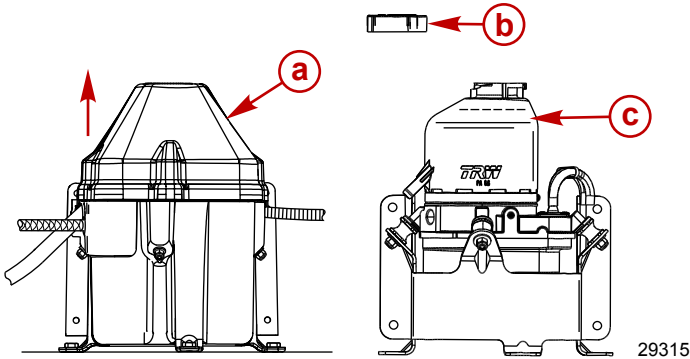

- a - Power steering cover
- b - Fill cap
- c - Fill/full level

Tube Ref No.	Description	Where Used	Part No.
 138	Synthetic Power Steering Fluid SAE 0W-30	Power steering system	92-858077K01

## Changing Engine Oil

### ENGINE OIL CAPACITY

Engine oil capacity is approximately 7.0 L (7.4 US qt).

### PUMP METHOD

**IMPORTANT:** Tilt the outboard out/up past vertical for approximately one minute to allow any trapped oil to drain back to the oil sump.

**IMPORTANT:** To reduce or prevent oil spillage when removing the oil filter, ensure that the outboard is upright (not tilted) and the engine is cold or has not run for at least one hour.

1. Tilt the outboard out/up past vertical for approximately one minute to allow any trapped oil to drain back to the oil sump.
2. Place the outboard in a vertical position.
3. Remove the dipstick.
4. Install the oil extraction tube to the crankcase oil pump.

# MAINTENANCE

**NOTE:** The oil extraction tube can be purchased from a Mercury Marine Outboard or MerCruiser service dealership.

5. Insert the oil extraction tube into the oil dipstick hole until the tube is at the bottom of the engine oil sump.
6. Pump the engine oil into an appropriate container.

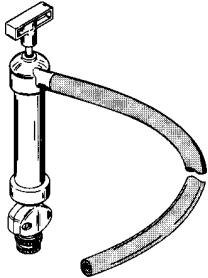
Crankcase Oil Pump	91-90265A 5
 <p>11591</p>	<p>Aids in the removal of engine oil without draining the crankcase.</p>

## DRAIN METHOD

**IMPORTANT:** The pump method is preferred to remove engine oil from XXL models. If the drain method is used, an oil drain funnel must be used to divert oil from the lower splash plate and into the container.

1. Tilt the outboard out/up past vertical for approximately one minute to allow any trapped oil to drain back to the oil sump.
2. Place the outboard in a vertical position.
3. Place an appropriate container under the engine oil sump plug. The drain plug/seal washer is located beneath the splash plate on the port side of the outboard.
4. Loosen the drain plug/seal washer. Install the oil drain funnel over the drain plug/seal washer.

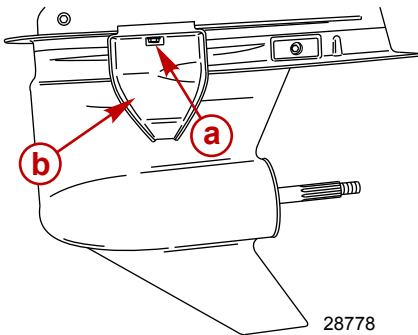

**a** - Drain plug/seal washer

**b** - Oil drain funnel



# MAINTENANCE

Oil Drain Funnel	91-892866A01
 <p>4993</p>	<p>Diverts draining engine oil from contacting the antisplash and anticavitation plates.</p>

5. Remove the drain plug/seal washer and drain the engine oil into a container.
6. Install the drain plug/seal washer.

## CHANGING OIL FILTER

**IMPORTANT:** To reduce or prevent oil spillage when removing the oil filter, ensure the outboard is upright (not tilted) and the engine is cold or has not run for at least one hour.

1. Remove the top cowl.
2. Place a rag or towel below the oil filter to absorb any spilled oil.
3. Remove the old filter with an oil filter wrench tool by turning the filter counterclockwise.



57127

**a -** Oil filter

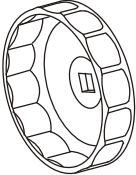
Oil Filter Wrench	91-889277
 <p>5221</p>	<p>Aids in the removal of the oil filter.</p>

4. Clean the oil filter mounting base.
5. Lubricate the new filter gasket with engine oil. Do not use grease.
6. Install the new filter until the gasket contacts the base, then tighten the filter an additional 3/4 to 1 turn.

# MAINTENANCE

## OIL FILLING

1. Remove the oil fill cap and add the recommended oil to the midpoint of the operating range (midpoint of crosshatched region on the dipstick). Adding approximately 7.0 L (7.4 US qt) will bring the oil level to midpoint of the crosshatched region on the dipstick.

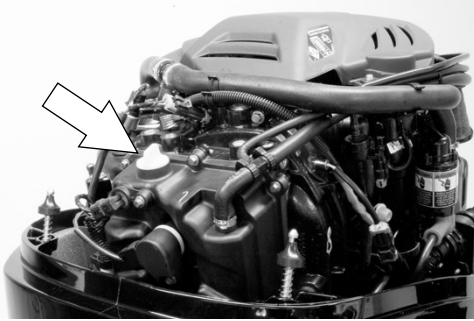

29681

2. Install the oil fill cap.
3. With the outboard in water or with a cooling water flush hose connected, idle the engine for five minutes to check for leaks at the oil filter.
4. Stop the engine and check the oil level. Refer to **Checking and Adding Engine Oil**.

## Gearcase Lubrication

When adding or changing gearcase lubricant, visually check for the presence of water in the lubricant. If water is present, it may have settled to the bottom and will drain out prior to the lubricant, or it may be mixed with the lubricant, giving it a milky colored appearance. If water is noticed, have the gearcase checked by your dealer. Water in the lubricant may result in premature bearing failure or, in freezing temperatures, will turn to ice and damage the gearcase.

Examine the drained gearcase lubricant for metal particles. A small amount of metal particles indicates normal gear wear. An excessive amount of metal filings or larger particles (chips) may indicate abnormal gear wear and should be checked by an authorized dealer.

## 122 MM (4.8 IN.) DIAMETER GEARCASE

### Draining Gearcase

1. Place outboard in a vertical operating position.
2. Remove propeller. Refer to **Propeller Replacement**.
3. Place drain pan below outboard.

# MAINTENANCE

4. Remove vent plug and fill/drain plug and drain lubricant.

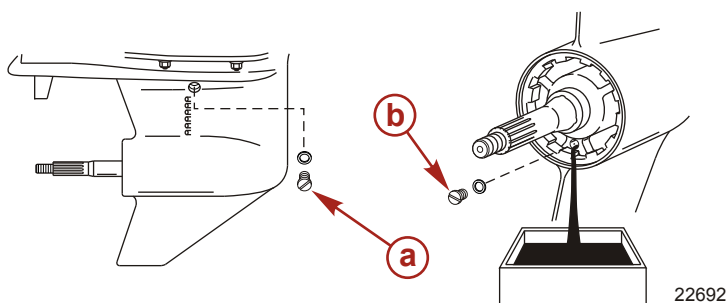

- a - Vent plug
- b - Fill/drain plug

## Gearcase Lubricant Capacity

Gearcase lubricant capacity is approximately 970 ml (32.8 fl oz).

## Gearcase Lubricant Recommendation

Mercury or Quicksilver High Performance Gear Lubricant.

## Checking Lubricant Level and Refilling Gearcase

1. Place outboard in a vertical operating position.
2. Remove vent plug/sealing washer.
3. Remove fill/drain plug. Place lubricant tube into the fill hole and add lubricant until it appears at the vent hole.

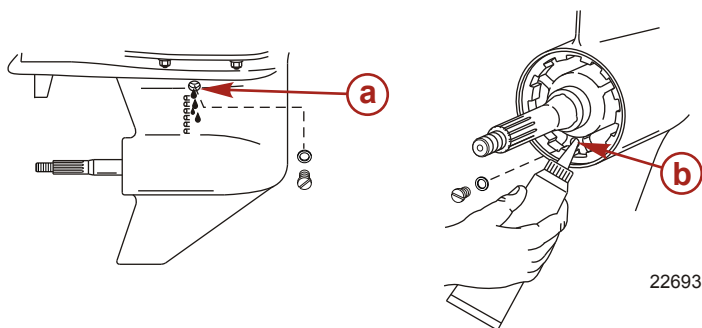

- a - Vent hole
- b - Fill hole

## IMPORTANT: Replace sealing washers if damaged.

4. Stop adding lubricant. Install the vent plug and sealing washer before removing the lubricant tube.

# MAINTENANCE

5. Remove lubricant tube and reinstall cleaned fill/drain plug and sealing washer.

## 137 MM (5.4 IN.) DIAMETER GEARCASE

### Gearcase Lubricant Capacity

Gearcase lubricant capacity is approximately 850 ml (28.7 fl oz).

### Gearcase Lubricant Recommendation

Mercury or Quicksilver High Performance Gear Lubricant.

### Draining Gearcase

1. Place the outboard in a vertical operating position.
2. Remove the propeller. Refer to **Propeller Replacement**.
3. Place a pan below the gear housing to capture the lubricant.
4. Remove the lubricant level plug and fill/drain plug. Allow a sufficient amount of time for the gearcase to drain. Depending on the ambient air temperature, it may take 30 minutes for the gearcase to completely drain.

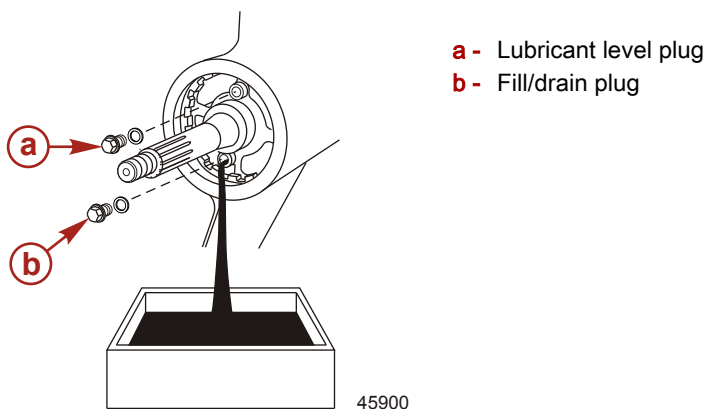

### Filling the Gearcase

1. After the gearcase has been drained, fill the gearcase through the fill/drain hole.
2. Allow a few minutes for the lubricant level to stabilize in the gearcase before installing the lubricant level plug. Install the lubricant level plug.

**IMPORTANT: Replace the sealing washers if damaged.**

3. Remove the tube and install the fill/drain plug.
4. Tighten the plugs to the specified torque.

# MAINTENANCE

Description	Nm	lb-in.	lb-ft
Plugs	11.3	100	–

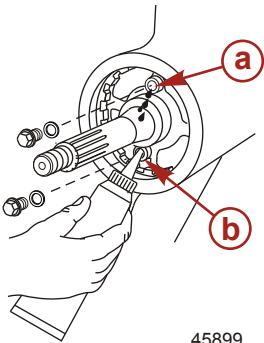

45899

- a** - Lubricant level hole
- b** - Fill hole

## Checking Lubricant Level

1. Place the outboard in a vertical operating position. Allow up to 30 minutes for the lubricant level to stabilize in the gear housing.
2. Remove the lubricant level plug. Verify the sealing washer is not adhered to the bearing carrier. The lubricant should be level with the hole or slowly leak from the hole.

### **IMPORTANT: Replace the sealing washers if damaged.**

3. If lubricant is not visible at the lubricant level hole, remove the fill/drain plug and add lubricant until it appears at the lubricant level hole.
4. Stop adding lubricant.
5. Allow a few minutes for the lubricant level to stabilize in the gearcase before installing the lubricant level plug. Install the lubricant level plug.
6. Remove the lubricant tube and install the fill/drain plug and sealing washer.
7. Tighten the plugs to the specified torque.

Description	Nm	lb-in.	lb-ft
Plugs	11.3	100	–

## HEAVY DUTY 137 MM (5.4 IN.) DIAMETER GEARCASE

### Gearcase Lubricant Capacity

Gearcase lubricant capacity is approximately 510 ml (17.2 fl oz).

### Gearcase Lubricant Requirement

Mercury or Quicksilver High Performance Gear Lubricant.

# MAINTENANCE

Tube Ref No.	Description	Where Used	Part No.
 87	High Performance Gear Lubricant	Gearcase	92-858064K01

## Draining Gearcase

1. Place the outboard in a vertical operating position.
2. Remove the propeller. Refer to **Propeller Replacement**.
3. Place a pan below the gear housing to capture the lubricant.
4. Remove the lubricant level plug and fill/drain plug. Allow a sufficient amount of time for the gearcase to drain. Depending on the ambient air temperature, it may take 30 minutes for the gearcase to completely drain.

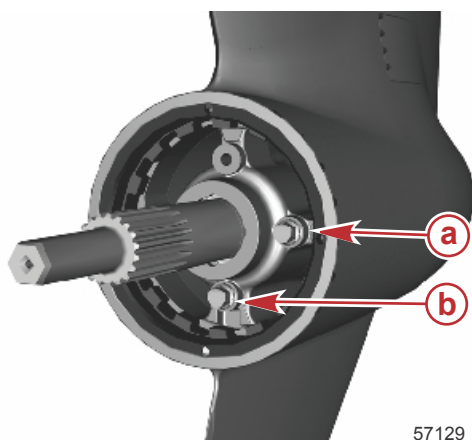

- a - Lubricant level plug
- b - Fill/drain plug

57129

## Filling the Gearcase

1. After the gearcase has been drained, fill the gearcase through the fill/drain hole.
2. Add the specified gear lubricant.

### **IMPORTANT: Replace the sealing washers if damaged.**

3. Allow a few minutes for the lubricant level to stabilize in the gearcase before installing the lubricant level plug. Install the lubricant level plug.
4. Remove the tube and install the fill/drain plug.
5. Tighten the plugs to the specified torque.

Description	Nm	lb-in.	lb-ft
Plugs	11.3	100	–

## Checking Lubricant Level

1. Place the outboard in a vertical operating position. Allow up to 30 minutes for the lubricant level to stabilize in the gear housing.

# MAINTENANCE

2. Remove the lubricant level plug. Verify the sealing washer is not adhered to the bearing carrier. The lubricant should be level with the hole or slowly leak from the hole.

**IMPORTANT: Replace the sealing washers if damaged.**

3. If lubricant is not visible at the lubricant level hole, remove the fill/drain plug and add lubricant until it appears at the lubricant level hole.
4. Stop adding lubricant.
5. Remove the lubricant tube and install the fill/drain plug and sealing washer.
6. Tighten the plugs to the specified torque.

Description	Nm	lb-in.	lb-ft
Plugs	11.3	100	–

# STORAGE

## Storage Preparation

The major consideration in preparing your outboard for storage is to protect it from rust, corrosion, and damage caused by freezing of trapped water.

The following storage procedures should be followed to prepare your outboard for out of season storage or prolonged storage (two months or longer).

### NOTICE

Without sufficient cooling water, the engine, the water pump, and other components will overheat and suffer damage. Provide a sufficient supply of water to the water inlets during operation.



## FUEL SYSTEM

**IMPORTANT:** Gasoline containing alcohol (ethanol or methanol) can cause a formation of acid during storage and can damage the fuel system. If the gasoline being used contains alcohol, it is advisable to drain as much of the remaining gasoline as possible from the fuel tank, remote fuel line, and engine fuel system.

**IMPORTANT:** This outboard is equipped with a closed fuel system. Fuel within the engine's fuel system, other than the fuel tank, will remain stable during normal storage periods without the addition of fuel treatment stabilizers.



Fill the fuel tank and engine fuel system with treated (stabilized) fuel to help prevent formation of varnish and gum. Proceed with the following instructions.

- Permanently installed fuel tank - Pour the required amount of Quickstor Fuel Stabilizer (follow instructions on container) into a separate container and mix with approximately one liter (one quart) of gasoline. Pour this mixture into the fuel tank.

Tube Ref No.	Description	Where Used	Part No.
 124 	Quickstor Fuel Stabilizer	Fuel tank	92-8M0047932

## Protecting External Outboard Components

- Touch up any paint nicks. See your dealer for touch-up paint.
- Spray Quicksilver or Mercury Precision Lubricants Corrosion Guard on external metal surfaces (except corrosion control anodes).

Tube Ref No.	Description	Where Used	Part No.
 120 	Corrosion Guard	External metal surfaces	92-802878 55

## Protecting Internal Engine Components

**IMPORTANT:** Refer to Maintenance - Spark Plug Inspection and Replacement for correct procedure for removing spark plugs.



# STORAGE

- Remove pencil coils and spark plugs.
- Spray approximately 30 ml (1 fl oz) of Storage Seal Rust Inhibitor into each spark plug hole.

Tube Ref No.	Description	Where Used	Part No.
 119	Storage Seal Rust Inhibitor	Spark plug holes	92-858081K03

- Actuate key/push button start switch to crank the engine through one start cycle, which will distribute the storage seal throughout the cylinders.
- Install spark plugs and pencil coils.

## Gearcase

- Drain and refill the gearcase lubricant (refer to **Gearcase Lubrication**).

## Positioning Outboard for Storage

Store outboard in an upright (vertical) position to allow water to drain out of the outboard.

### *NOTICE*

Storing the outboard in a tilted position can damage the outboard. Water trapped in the cooling passages or rain water collected in the propeller exhaust outlet in the gearcase can freeze. Store the outboard in the full down position.

## Battery Storage

- Follow the battery manufacturer's instructions for storage and charging.
- Remove the battery from the boat and check water level. Charge if necessary.
- Store the battery in a cool, dry place.
- Periodically check the water level and charge the battery during storage.

# TROUBLESHOOTING

## Starter Motor Will Not Crank the Engine

### POSSIBLE CAUSES

- Lanyard stop switch not in RUN position.
- Blown 5-amp fuse. Check DTS power harness circuit fuse. Refer to **Maintenance** section.
- Remote control is not shifted to the neutral position.
- Shift actuator failure. Turn ignition key switch off to reset and then start the engine.
- Weak battery or battery connections are loose or corroded.
- Ignition key switch failure.
- Wiring or electrical connection faulty.
- Starter motor solenoid or start solenoid failure.

## Engine Will Not Start

### POSSIBLE CAUSES

- Incorrect starting procedure. Refer to **Operation** section.
- Old or contaminated gasoline.
- Fuel is not reaching the engine.
  - Fuel tank is empty.
  - Fuel tank vent not open or restricted.
  - Fuel line is disconnected or kinked.
  - Fuel filter is obstructed. Refer to **Maintenance** section.
  - Fuel pump failure.
  - Fuel tank filter obstructed.
- Ignition system component failure.
- Spark plugs fouled or defective. Refer to **Maintenance** section.

## Engine Starts But Will Not Shift Into Gear

- Throttle only mode is engaged.
- Shift actuator failure. Turn ignition key switch off to reset and then start the engine.

## Engine Runs Erratically

### POSSIBLE CAUSES

- Overheating—warning horn not working.
- Low oil pressure. Check oil level.
- Spark plugs fouled or defective. Refer to **Maintenance** section.
- Incorrect setup and adjustments.
- Fuel is being restricted to the engine.

# TROUBLESHOOTING

- a. Engine fuel filter is obstructed. Refer to **Maintenance** section.
- b. Fuel tank filter obstructed.
- c. Stuck anti-siphon valve located on permanently built-in type fuel tanks.
- d. Fuel line is kinked or pinched.
- Fuel system is not primed.
- Fuel pump failure.
- Ignition system component failure.

## Performance Loss

### POSSIBLE CAUSES

- Overheating—warning horn not working.
- Low oil pressure. Check oil level.
- Throttle not opening fully.
- Damaged propeller or improper propeller size.
- Low water pressure.
- Low battery voltage.
- Worn, stretched or broken accessory belt.
- Boat overloaded or load improperly distributed.
- Excessive water in bilge.
- Boat bottom is dirty or damaged.
- Air filter or intake screen that is partially blocked with debris.

## Battery Will Not Hold Charge

### POSSIBLE CAUSES

- Battery connections are loose or corroded.
- Low electrolyte level in battery.
- Worn out or inefficient battery.
- Excessive use of electrical accessories.
- Defective rectifier, alternator, or voltage regulator.
- Open circuit in the alternator output wire (fused link).
- Worn or stretched accessory belt.

# OWNER SERVICE ASSISTANCE

## Service Assistance

### LOCAL REPAIR SERVICE

If you need service for your Mercury-outboard-powered boat, take it to your authorized dealer. Only authorized dealers specialize in Mercury products and have factory-trained mechanics, special tools and equipment, and genuine Quicksilver parts and accessories to properly service your engine.

**NOTE:** *Quicksilver parts and accessories are engineered and built by Mercury Marine specifically for your power package.*

### SERVICE AWAY FROM HOME

If you are away from your local dealer and the need arises for service, contact the nearest authorized dealer. If, for any reason, you cannot obtain service, contact the nearest Regional Service Center. Outside the United States and Canada, contact the nearest Marine Power International Service Center.

### STOLEN POWER PACKAGE

If your power package is stolen, immediately advise the local authorities and Mercury Marine of the model and serial numbers and to whom the recovery is to be reported. This information is maintained in a database at Mercury Marine to aid authorities and dealers in the recovery of stolen power packages.

### ATTENTION REQUIRED AFTER SUBMERSION

1. Before recovery, contact an authorized Mercury dealer.
2. After recovery, immediate service by an authorized Mercury dealer is required to reduce the possibility of serious engine damage.

### REPLACEMENT SERVICE PARTS

#### WARNING

**Avoid fire or explosion hazard. Electrical, ignition, and fuel system components on Mercury Marine products comply with federal and international standards to minimize risk of fire or explosion. Do not use replacement electrical or fuel system components that do not comply with these standards. When servicing the electrical and fuel systems, properly install and tighten all components.**

Marine engines are expected to operate at or near full throttle for most of their lives. They are also expected to operate in both fresh and saltwater environments. These conditions require numerous special parts.

### PARTS AND ACCESSORIES INQUIRIES

Direct any inquiries concerning genuine Mercury Precision Parts® or Quicksilver Marine Parts and Accessories® to a local authorized dealer. Dealers have the proper systems to order parts and accessories, if they are not in stock. **Engine model** and **serial number** are required to order correct parts.

# OWNER SERVICE ASSISTANCE

## RESOLVING A PROBLEM

Satisfaction with your Mercury product is important to your dealer and to us. If you ever have a problem, question or concern about your power package, contact your dealer or any authorized Mercury dealership. If you need additional assistance:

1. Talk with the dealership's sales manager or service manager.
2. If your question, concern, or problem cannot be resolved by your dealership, please contact the Mercury Marine Service Office for assistance. Mercury Marine will work with you and your dealership to resolve all problems.

The following information will be needed by the Customer Service:

- Your name and address
- Your daytime telephone number
- The model and serial numbers of your power package
- The name and address of your dealership
- The nature of the problem

## CONTACT INFORMATION FOR MERCURY MARINE CUSTOMER SERVICE

For assistance, call, fax, or write to the geographic office in your area. Please include your daytime telephone number with mail and fax correspondence.

<b>United States, Canada</b>		
Telephone	English +1 920 929 5040 Français +1 905 636 4751	Mercury Marine W6250 Pioneer Road P.O. Box 1939 Fond du Lac, WI 54936-1939
Fax	English +1 920 929 5893 Français +1 905 636 1704	
Website	www.mercurymarine.com	

<b>Australia, Pacific</b>		
Telephone	+61 3 9791 5822	Brunswick Asia Pacific Group 41-71 Bessemer Drive Dandenong South, Victoria 3175 Australia
Fax	+61 3 9706 7228	

<b>Europe, Middle East, Africa</b>		
Telephone	+32 87 32 32 11	Brunswick Marine Europe Parc Industriel de Petit-Rechain B-4800 Verviers, Belgium
Fax	+32 87 31 19 65	

# OWNER SERVICE ASSISTANCE

<b>Mexico, Central America, South America, Caribbean</b>		
Telephone	+1 954 744 3500	Mercury Marine 11650 Interchange Circle North Miramar, FL 33025 U.S.A.
Fax	+1 954 744 3535	

<b>Japan</b>		
Telephone	+072 233 8888	Kisaka Co., Ltd. 4-130 Kannabecho, Sakai-ku Sakai-shi, Osaka 590-0984, Japan
Fax	+072 233 8833	

<b>Asia, Singapore</b>		
Telephone	+65 65466160	Brunswick Asia Pacific Group T/A Mercury Marine Singapore Pte Ltd 29 Loyang Drive Singapore, 508944
Fax	+65 65467789	

## Ordering Literature

Before ordering literature, have the following information about your power package available:

Model		Serial Number	
Horsepower		Year	

## UNITED STATES AND CANADA

For additional literature for your Mercury Marine power package, contact your nearest Mercury Marine dealer or contact:

<b>Mercury Marine</b>		
<b>Telephone</b>	<b>Fax</b>	<b>Mail</b>
(920) 929-5110 (USA only)	(920) 929-4894 (USA only)	Mercury Marine Attn: Publications Department P.O. Box 1939 Fond du Lac, WI 54936-1939

## OUTSIDE THE UNITED STATES AND CANADA

Contact your nearest Mercury Marine authorized service center to order additional literature that is available for your particular power package.

# OWNER SERVICE ASSISTANCE

Submit the following order form with payment to:	Mercury Marine Attn: Publications Department W6250 Pioneer Road P.O. Box 1939 Fond du Lac, WI 54936-1939
--	--

**Ship To: (Copy this form and print or type—This is your shipping label)**

<b>Name</b>	
<b>Address</b>	
<b>City, State, Province</b>	
<b>ZIP or postal code</b>	
<b>Country</b>	

Quantity	Item	Stock Number	Price	Total
			.	.
			.	.
			.	.
			.	.
			.	.
Total Due			.	.

# INSTALLATION

## Outboard Installation

### MERCURY MARINE VALIDATED ENGINE MOUNTING HARDWARE

**IMPORTANT:** Mercury Marine provides validated fasteners and installation instructions, including torque specifications, with all of our outboards so they can be properly secured to boat transoms. Improper installation of the outboard can cause performance and reliability issues that can lead to safety concerns. Follow all of the instructions relating to the outboard installation. **DO NOT** mount any other accessory onto the boat with the fasteners provided with the outboard. For example, do not mount a tow sport bars or boarding ladders onto the boat using the mounting hardware included with the outboard. Installing other products onto the boat that utilize the outboard mounting hardware will compromise the ability of that hardware to properly and safely secure the outboard to the transom.

Outboards that require validated mounting hardware will have the following decal on the transom clamp.



51965

### FASTENING HARDWARE SPECIFICATION (NOT FACTORY SUPPLIED)

**IMPORTANT:** Mercury Marine has designed and tested the engine when it is directly mounted to the transom, jack plate, or setback plate using the mounting hardware included with the engine. Torque requirements have been established using the hardware included with the engine. The use of mounting hardware not supplied by the factory, must be equal to, or greater than the following specifications.

- Bolt specifications:



# INSTALLATION

<b>Must be a hex head bolt with an unthreaded shank length of not less than 1 inch</b>	
Thread size	0.50-20 inch UNF - 2A thread
Material	Austenitic stainless steel grade 304 or 316
Minimum mechanical properties	90,000 psi ultimate tensile strength/50,000 psi yield strength. This corresponds to a F593C bolt head marking per American Society for Testing and Materials (ASTM).



- Nut specifications:

<b>Nut to be a prevailing torque, full height nut, nylon 6/6 or equivalent insert</b>	
Thread size	0.50-20 inch UNF thread
Material	Brass, Grade Cu 613 per ASTM
Minimum mechanical properties	80,000 psi proof stress. This corresponds to a F467F mechanical marking per ASTM.

- Washer specifications:

This washer is for use on the transom bracket side of the application	0.88 x 0.53 x 0.104 inch flat washer, 630 (H1025) hardened stainless steel
This washer is for use on the transom side of the application	1.5 x 0.515 x 0.125 inch flat washer, 302, 304, or 316 stainless steel

# INSTALLATION

## ACCESSORIES MOUNTED TO THE TRANSOM CLAMP BRACKET

Mercury Marine has been made aware that certain aftermarket marine accessories, such as emergency boarding ladders, shallow water anchors, transom wedge kits, and tow sport attaching devices, have been mounted to the boat by use of the same fasteners that secure the outboard to the transom or jack plate. Using the same fastener to secure both an accessory and the engine to the boat compromises the ability of the fasteners to maintain the proper clamp load. A boat with loose engine mounting fasteners creates the possibility of performance, durability, and safety issues.

### **▲ WARNING**

**Avoid serious injury or death resulting from a loss of boat control. Loose engine fasteners could cause the transom bracket to fail, resulting in a loss of the driver's ability to control the boat. Always ensure that the engine fasteners are tightened to the specified torque.**

### **Acceptable Accessory Mounting to the Transom Clamp Bracket**

After the engine is mounted to the transom or jack plate in accordance with the engine installation instructions, it is acceptable to attach an accessory to the boat by use of the unused bolt holes in the transom clamp bracket as shown in Figure 1.

The following list provides additional guidelines for mounting accessories to the transom clamp bracket.

- The accessory fasteners must pass through the boat transom or jack plate.

# INSTALLATION

- The installation must not create interference issues, as would an accessory mounting plate resting in the radius of the transom clamp bracket. Refer to Figure 1.

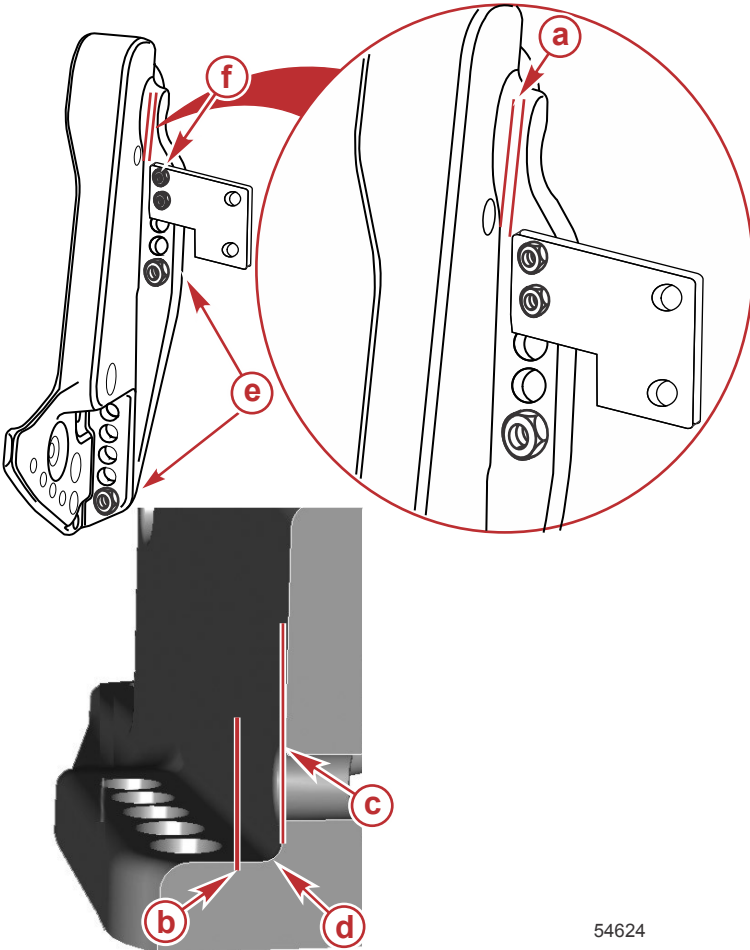

54624

**Figure 1**

- a** - Minimum clearance 3.175 mm (0.125 in.)
- b** - Edge of accessory bracket
- c** - Transom clamp bracket wall
- d** - Radius
- e** - Engine supplied mounting fasteners
- f** - Fasteners supplied by the accessory manufacturer installed through unused engine mounting bracket holes

# INSTALLATION

## Unacceptable Accessory Mounting

**IMPORTANT:** Do not use the fasteners that secure the engine to the boat (either the transom or the jack plate) for any purpose other than securing the engine to the boat.

1. Do not mount an accessory to the transom clamp bracket in an unsupported condition. Refer to Figure 2.

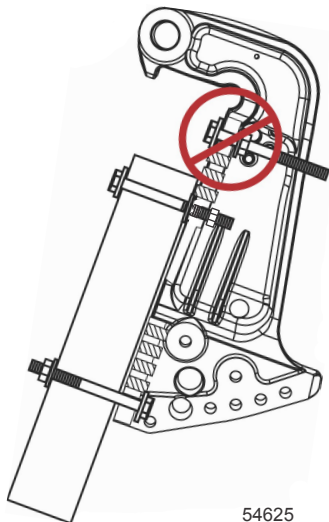

**Figure 2**

2. Do not attach an accessory to the boat by use of the engine mounting hardware. Refer to Figure 3.

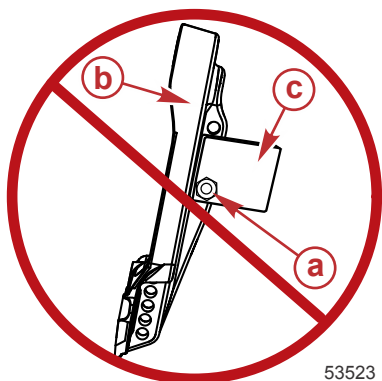
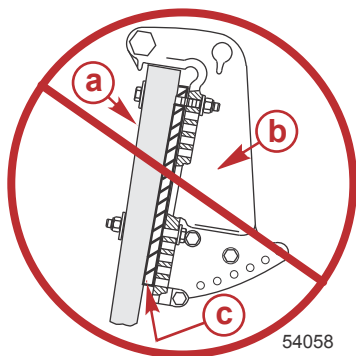

**Figure 3**

- a** - Engine supplied mounting fasteners
- b** - Transom clamp bracket
- c** - Accessory

# INSTALLATION

3. Do not install wedges or plates between the transom clamp brackets and the transom (or jack plate). Refer to Figure 4.



**Figure 4**

- a** - Boat transom or jack plate
- b** - Transom clamp bracket
- c** - Wedge/plate

## FASTENING THE OUTBOARD

### **⚠ WARNING**

Failure to correctly fasten the outboard could result in the outboard propelling off the boat transom resulting in property damage, serious injury, or death. Before operation, the outboard must be correctly installed with the required mounting hardware.

**IMPORTANT:** For optimum boat performance and detailed engine installation instructions, refer to the outboard installation manual, supplied with the outboard.

We strongly recommend that your dealer install your outboard and related accessories to ensure proper installation and good performance. If you install the outboard yourself, follow instructions in the Outboard Installation Manual which is provided with the outboard.

# INSTALLATION

## Required Mounting Installation 200–350 HP

The outboard must be secured to the boat transom with the four 12.7 mm (1/2 in.) diameter mounting screws, locknuts, and washers provided. Install two screws through the upper set of mounting holes and two screws through the lower set of mounting slots.

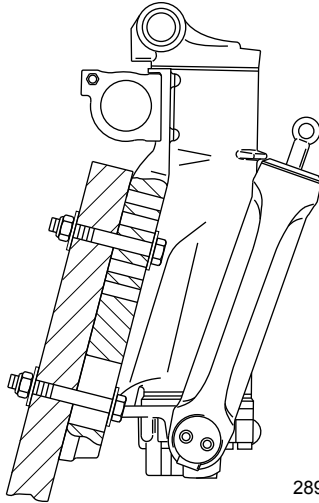

28923

## Recommended Mounting Installation 300–350 HP

The outboard should be secured to the boat transom with the six 12.7 mm (1/2 in.) diameter mounting screws with two nuts on each screw. The two top screws must have one vacant transom mounting bracket hole between the screws. Only one locknut per screw is allowed.

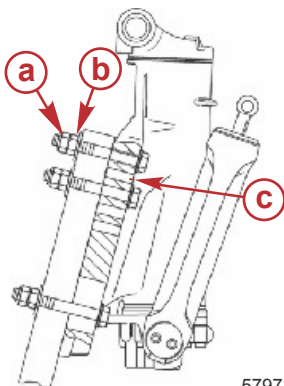

57973

- a** - Locknut
- b** - Nut
- c** - Vacant transom mounting bracket hole

# MAINTENANCE LOG

## Maintenance Log

Record all maintenance performed on your outboard here. Be sure to save all work orders and receipts.

Date	Maintenance Performed	Engine Hours